

# MasterPatio

Cat. nr. **34G**  
Art. nr. **PP\_AD.089.G34D.00 (v01)**  
Edition **10/2022**



**Together for better**

[www.reynaers.com](http://www.reynaers.com)

**Inhoud**  
**Sommaire**  
**Content**  
**Inhalt**



Reynaers  
Aluminium

- A**    **Algemene informatie**  
         **Généralités**  
         **General Information**  
         **Allgemeine Information**
- B**    **Algemene informatie systemen**  
         **Généralités séries**  
         **General Information System**  
         **Allgemeine Information System**
- C**    **Profielen**  
         **Profilés**  
         **Profiles**  
         **Profile**
- E**    **Werktekeningen**  
         **Coupes et débits**  
         **Work drawings**  
         **Werkzeichnungen**
- F**    **Montagetekeningen**  
         **Fabrication et montage**  
         **Assembly drawings**  
         **Montagezeichnungen**
- G**    **Toebehoren**  
         **Accessoires**  
         **Accessories**  
         **Zubehör**



## Inhoud

INHOUDSTAFEL 34G.001-008

## Algemene informatie

SYMBOLENLIJST 34G.A.001-008

## Algemene informatie systeme

VERWERKINGSVOORSCHRIFTEN 34G.B.001-040  
TECHNISCHE INFORMATIE 34G.B.041-072  
GEMOTORISEERD ALGEMENE INFORMATIE: BESLISSINGEN 34G.B.072\_01.001-072\_01.004

## Profielen

PROFIELLIJST 34G.C.001  
PROFIELOVERZICHT 34G.C.002-010  
BUITENKADER MONORAIL ONDER 34G.C.011-013  
BUITENKADER MONORAIL BOVEN 34G.C.014  
BUITENKADER 2-RAIL ONDER/BOVEN 34G.C.015  
BUITENKADER 3-RAIL ONDER/BOVEN 34G.C.016  
BUITENKADER ZIJKANT 34G.C.017-019  
PROFIEL BUITENKADER KUNSTSTOF 34G.C.020  
AFDEKPROFIEL 34G.C.021-022  
VLEUGELPROFIEL 34G.C.023  
STANDAARD WISSELPROFIEL 34G.C.024  
SMAL WISSELPROFIEL 34G.C.025  
HULPPROFIELEN 34G.C.026-027  
GLASLATTEN 34G.C.028-030  
GLASLATTEN RC2 / RC3 34G.C.031-032  
GLASLATTEN 34G.C.033-034  
RAIL 34G.C.035  
VERSTERKINGSPROFIELEN 34G.C.036-038  
AFWERKINGSPROFIEL 34G.C.039  
OMKEERPROFIEL 34G.C.040  
KOPPELPROFIEL 34G.C.041-042  
T-PROFIEL VERSTERKT 34G.C.043  
KOPPELPROFIEL 34G.C.044  
DILATATIEPROFIEL 34G.C.045  
Z-PROFIEL 34G.C.046-048  
ROLLUIKGELEIDER 34G.C.049-051  
MUURAFWERKINGSPROFIEL 34G.C.052  
STEUNPROFIEL 34G.C.053  
GOOT 34G.C.054

## Werktekeningen

OVERZICHT CONFIGURATIES 34G.E.001-003  
OVERZICHT MAGNEET CONTACT 34G.E.004-005  
OVERZICHT GEMOTORISEERDE CONFIGURATIES 34G.E.005\_01.001-005\_01.002  
OVERZICHT ISOLATIE VARIANTEN 34G.E.006-049  
MONORAIL XQ BUITENBEGLAZING 34G.E.050-055  
MONORAIL QXQ BUITENBEGLAZING 34G.E.056-059  
MONORAIL QXQ BUITENBEGLAZING 34G.E.060-063  
MONORAIL QXXQ BUITENBEGLAZING 34G.E.064-065  
MONORAIL XQVQ BUITENBEGLAZING OC 34G.E.066-071  
MONORAIL XQVQ BUITENBEGLAZING IC 34G.E.072-075  
MONORAIL XQVQX BUITENBEGLAZING OC 34G.E.076-077  
MONORAIL XQVQX BUITENBEGLAZING IC 34G.E.078-079  
MONORAIL XQ BUITENBEGLAZING SMALLE CHICANE 34G.E.080-081  
MONORAIL BUITENBEGLAZING VARIANT BODEMPROFIEL 34G.E.082  
MONORAIL BUITENBEGLAZING VARIANT TOPPROFIEL 34G.E.083  
MONORAIL XQ BUITENBEGLAZING AP 34G.E.084-089  
MONORAIL XQ BINNENGLAZING 34G.E.090-095  
MONORAIL XQX BINNENGLAZING 34G.E.096-099  
MONORAIL QXXQ BINNENGLAZING 34G.E.100-101  
MONORAIL XQVQ BINNENGLAZING OC 34G.E.102-107  
MONORAIL XQVQ BINNENGLAZING IC 34G.E.108-111  
MONORAIL XQVQX BINNENGLAZING IC 34G.E.112-113  
MONORAIL XQVQX BINNENGLAZING OC 34G.E.114-115  
MONORAIL XQ BINNENGLAZING SMALLE CHICANE 34G.E.116-117  
MONORAIL XQ BINNENBEGLAZING AP 34G.E.118-123  
MONORAIL BINNENGLAZING VARIANT TOPPROFIEL 34G.E.123\_01.001-123\_01.002  
2-RAIL XQ 34G.E.124-129  
2-RAIL XX 34G.E.130-135  
2-RAIL QXQ 34G.E.136-139  
2-RAIL QXQ 34G.E.140-143  
2-RAIL QXXX 34G.E.144-145  
2-RAIL XXXX 34G.E.146-149  
2-RAIL XQ SMALLE CHICANE 34G.E.150-151  
2-RAIL XQ AP 34G.E.152-157  
3-RAIL XXQ 34G.E.158-163  
3-RAIL XXX 34G.E.164-169  
3-RAIL QXXXXX 34G.E.170-171  
3-RAIL XXXXXX 34G.E.172-173  
BUITENKADER VERBORGEN ONTWATERING 34G.E.174-175  
VARIANT VLEUGEL BUITENBEGLAZING 34G.E.175\_01.001-175

## Montagetekeningen

MAX. TOELAATBARE AFMETINGEN STANDAARD CHICANE 34G.F.001-021  
MAX. TOELAATBARE AFMETINGEN SMALLE CHICANE 34G.F.022-038  
VERSTERKINGS T-PROFIEL 34G.F.039  
MONTAGEVOLGORDE KADER 34G.F.040-041  
MONTAGE GEBASEERD OP PERFORMANTIE 34G.F.041\_01.001-041\_01.002  
ONTWATERING MONORAIL BUITENBEGLAZING 34G.F.042-073  
ONTWATERING MONORAIL BINNENBEGLAZING 34G.F.074-095  
ONTWATERING 2-RAIL 34G.F.096-111  
ONTWATERING 3-RAIL 34G.F.112-123  
SNIJDEN VAN AFDICHTING BUITENKADER 080.9738.04 34G.F.124-125  
SNIJDEN VAN AFDICHTING BUITENKADER 080.9724.04/1 34G.F.126-127  
MONTAGE VAN PROFIEL BUITENKADER KUNSTSTOF 406 34G.F.127\_01.001-127\_01.002  
VOORBEREIDING BUITENKADER MONORAIL SLOTZIJDJE 34G.F.128  
MONTAGE BUITENKADER MONORAIL SLOTZIJDJE 34G.F.129  
VOORBEREIDING BUITENKADER MONORAIL VASTE ZIJDI 34G.F.130  
MONTAGE BUITENKADER MONORAIL VASTE ZIJDE 34G.F.131  
VOORBEREIDING BUITENKADER 2-RAIL 34G.F.132

MONTAGE BUITENKADER 2-RAIL 34G.F.133  
VOORBEREIDING BUITENKADER 3-RAIL 34G.F.134-135  
MONTAGE BUITENKADER 3-RAIL 34G.F.136-137  
MONTAGE AFDICHTING CHICANE OG 34G.F.138-139  
MONTAGE AFDICHTING CHICANE IG 34G.F.140-141  
MONTAGE AFDICHTING CHICANE 2-RAIL/3-RAIL 34G.F.142-143  
T-VERBINDINGEN 34G.F.144-149\_01.002  
KADER STANDAARD CHICANE OG 34G.F.150-151  
KADER SMALLE CHICANE OG 34G.F.152-153  
KADER STANDAARD CHICANE IG + OG VARIANT 34G.F.154-155  
KADER SMALLE CHICANE IG + OG VARIANT 34G.F.156-157  
VOORBEREIDING QXQ PROFIEL 34G.F.158-159  
VOORBEREIDING AFDEKPROFIEL QXQ 34G.F.160-161  
MONTAGE QXQ PROFIEL 34G.F.162-163  
MONTAGE VLEUGEL 34G.F.164-165  
VOORBEREIDING STANDAARD CHICANE 34G.F.166-167\_01.002  
VOORBEREIDING SMALLE CHICANE 34G.F.168-169\_01.002  
ONTWATERING + DECOMPRESSIE VLEUGEL 34G.F.170-171  
ONTWATERING + DECOMPRESSIE OMGEKEERDE VLEUGEL 34G.F.171\_01.001-171\_01.002  
UITFREZING VOOR WIELEN 34G.F.172-177  
SLOTEN (+KABA) 34G.F.178-179  
UITFREZING VOOR SLOTEN 34G.F.180-181  
AFDEKKAP SLOT 34G.F.182-183  
KRUK OVERZICHT 34G.F.184-185  
UITFREZING DEURKRUKKEN TOUCH 34G.F.186-193  
UITFREZING DEURKRUKKEN HORIZON 34G.F.194-201  
UITFREZINGEN DEURKRUKKEN SIEGENIA 34G.F.202-207  
UITFREZING DEURKRUKKEN CONTOUR 34G.F.208-213  
UITFREZING DEURKRUKKEN PURITY 34G.F.214-219  
UITFREZING DEURKRUKKEN OLIMPO 34G.F.219\_01.001-219\_01.008  
BESLISSINGSMATRIX CILINDER 34G.F.220-221  
HOEKVERBINDING VLEUGEL 34G.F.222-223  
PERSHOEKVERBINDING 34G.F.224-225  
MONTAGE STANDAARD CHICANE 34G.F.226-227  
MONTAGE SMALLE CHICANE 34G.F.228-229  
MONTAGE SCHUIFVLEUGEL 34G.F.230  
MONTAGE LOOPWAGEN 34G.F.231-231\_01.002  
MONTAGE SLOT 34G.F.232  
MONTAGE HANDVAT 34G.F.233  
MONTAGE SLOT AP 34G.F.234-235  
MONTAGE VASTE VLEUGEL 2-RAIL 34G.F.236-237  
MONTAGE KRUK 062.6649.XX 34G.F.238  
MONTAGE KOMGREEP 34G.F.239  
STEUNSTUK VASTE VLEUGEL 34G.F.240-243  
MONTAGE AFSTANDSTUKKEN 34G.F.244-245  
GLASSTEUNEN 34G.F.246-255  
BEGLAZINGSTABEL 34G.F.256-257  
BEGLAZINGSTABEL SMALLE CHICANE 34G.F.258-259  
BIJKOMENDE GLASSTEUN 34G.F.260  
VERLIJMEN GLAS SMALLE CHICANE 34G.F.261  
MONTAGE 34G.F.262-263  
MONTAGE KLEMSTUK 34G.F.264-265  
MONTAGE ONTVANGERS 34G.F.266-269  
AFSTELLEN SLUITPUNTEN 34G.F.270-271  
BUFFER 34G.F.272-277  
MONTAGE 4-SLAG VLEUGEL 34G.F.278-279  
MONTAGE ONTVANGER 4-SLAG VLEUGEL 34G.F.280-281  
VERSTERKINGSPROFIELEN 34G.F.282-285  
VARIANT AFDICHTING 34G.F.286-287  
MONTAGE AP 34G.F.288-293  
AFWERKINGSPROFIEL 34G.F.294-299  
SAFETY DEVICE 34G.F.299\_01.001-299\_01.008  
VOORGESCHREVEN POSITIE VERLENGING ONDERREGEL 34G.F.300-303  
KOPPELSTUKKEN 34G.F.304-309  
KOPPELSTUKKEN HOEK 34G.F.310-313  
KOPPELINGEN MET ANDERE SYSTEMEN 34G.F.314-329  
DILATATIEPROFIEL 34G.F.330-331  
BALUSTRADE 34G.F.332-333  
GOOT 34G.F.334-335  
BOUWAANSLUITING 34G.F.336-339  
MAGNEET CONTACT 34G.F.340-345  
MOTOR UITFREZING BOVENPROFIEL BESLAG 34G.F.345\_01.001-345\_01.018  
MOTOR UITFREZING+MONTAGE BESLAG 34G.F.345\_01.019-345\_01.043

## Toebehoren

OVERZICHT 34G.G.001  
HOEKVERBINDER 34G.G.002  
HOEKVERBINDER GLAS HOEK 34G.G.003  
HOEKEN 34G.G.004  
T-VERBINDERS 34G.G.005-005\_01.002  
AFDICHTING 34G.G.006-008  
DICHTING / VULSTUK ISOLEREND 34G.G.009-010  
AFDICHTING MET BORSTEL 34G.G.011-012  
GLASSTEUN 34G.G.013  
DICHTINGEN 34G.G.015-017  
BEGLAZINGSDICHTING 34G.G.018-021  
BORSTELDICHTINGEN 34G.G.022  
ALGEMENE TOEBEHOREN 34G.G.023-028  
TOEBEHOREN INBRAAKWEREND 34G.G.029  
EINDSTUKKEN 34G.G.030  
EINDSTUK 34G.G.031-033  
KOPPELSTUK 34G.G.034  
SLOTEN 34G.G.035-037  
CILINDERS 34G.G.038  
LOOPWAGEN 34G.G.039  
TOUCH DEURKRUKKEN 34G.G.040-041  
DEURKRUKKEN PURITY 34G.G.042-043  
DEURKRUKKEN HEFSCHUIFDEUR 34G.G.044-048  
DEURKRUKKEN KABA 34G.G.049  
VIERTAKSTIJFT 34G.G.050  
OVERZICHT SAFETY DEVICE 34G.G.050\_01.001  
ANKERSTUK 34G.G.051-052  
GELEIDE MATRIJS 34G.G.053  
BOORMALLEN 34G.G.054-056  
GEREEDSCHAPPEN 34G.G.057  
MAGNEET CONTACT 34G.G.058  
MOTOR 34G.G.058\_01.001-058\_01.011



## Sommaire

TABLE DES MATIERES 34G.001-008

## Généralités

LISTE DES SYMBOLES 34G.A.001-008

## Généralités séries

PRESRIPTIONS DE MISE EN OEUVRE 34G.B.001-040  
INFORMATION TECHNIQUE 34G.B.041-072  
MOTORISÉES INFORMATION GENERALITES: MATRICE DE 34G.B.072\_01.001-072\_01.004

## Profilés

LISTE DES PROFILES 34G.C.001  
APERCU DES PROFILES 34G.C.002-010  
DORMANT MONORAIL BAS 34G.C.011-013  
DORMANT MONORAIL EN HAUT 34G.C.014  
DORMANT 2-RAIL EN BAS/EN HAUT 34G.C.015  
DORMANT 3-RAIL EN BAS/EN HAUT 34G.C.016  
DORMANT COTE LATERAL 34G.C.017-019  
PROFILE SYNTHETIQUE DORMANT 34G.C.020  
PROFILE DE RECouvreMENT 34G.C.021-022  
PROFILE OUVRANT 34G.C.023  
CHICANE CLASSIQUE 34G.C.024  
CHICANE ETROITE 34G.C.025  
PROFILES DE RACCORDEMENT 34G.C.026-027  
PARCLOSES 34G.C.028-030  
PARCLOSES RC2 / RC3 34G.C.031-032  
PARCLOSES 34G.C.033-034  
RAIL 34G.C.035  
PROFILES DE RENFORCEMENT 34G.C.036-038  
PROFILE DE FINITION 34G.C.039  
PROFILE INVERSION 34G.C.040  
PROFILE DE RACCORDEMENT 34G.C.041-042  
TRAVERSE RENFORCEE 34G.C.043  
PROFILE DE RACCORDEMENT 34G.C.044  
PROFILE DE DILATATION 34G.C.045  
PROFILE-Z 34G.C.046-048  
GUIDE A VOLET 34G.C.049-051  
PROFILE DE FINITION 34G.C.052  
PROFILE DE SUPPORT 34G.C.053  
GOUTTIERE 34G.C.054

## Coupes et débits

APERCU CONFIGURATIONS 34G.E.001-003  
APERCU CONTACT MAGNETIQUE 34G.E.004-005  
APERCU CONFIGURATIONS MOTORISE 34G.E.005\_01.001-005\_01.002  
APERCU VARIANTES D'ISOLATION 34G.E.006-049  
MONORAIL XQ INVERSION PARCLOSE 34G.E.050-055  
MONORAIL XQX INVERSION PARCLOSE 34G.E.056-059  
MONORAIL QXQ INVERSION PARCLOSE 34G.E.060-063  
MONORAIL QXXQ INVERSION PARCLOSE 34G.E.064-065  
MONORAIL XQVQ INVERSION PARCLOSE OC 34G.E.066-071  
MONORAIL XQVQ INVERSION PARCLOSE IC 34G.E.072-075  
MONORAIL XQVQX INVERSION PARCLOSE OC 34G.E.076-077  
MONORAIL XQVQX INVERSION PARCLOSE IC 34G.E.078-079  
MONORAIL XQ INVERSION PARCLOSE CHICANE ETROITE 34G.E.080-081  
MONORAIL INVERSION PARCLOSE PROFILE EN BASE VAF 34G.E.082  
MONORAIL INVERSION PARCLOSE PROFILE EN HAUT VAF 34G.E.083  
MONORAIL XQ INVERSION PARCLOSE AP 34G.E.084-089  
MONORAIL XQ INTERIEUR PARCLOSE 34G.E.090-095  
MONORAIL XQX INTERIEUR PARCLOSE 34G.E.096-099  
MONORAIL QXXQ INTERIEUR PARCLOSE 34G.E.100-101  
MONORAIL XQVQ INTERIEUR PARCLOSE OC 34G.E.102-107  
MONORAIL XQVQ INTERIEUR PARCLOSE IC 34G.E.108-111  
MONORAIL XQVQX INTERIEUR PARCLOSE OC 34G.E.112-113  
MONORAIL XQVQX INTERIEUR PARCLOSE IC 34G.E.114-115  
MONORAIL XQ INTERIEUR PARCLOSE CHICANE ETROITE 34G.E.116-117  
MONORAIL XQ INTERIEUR PARCLOSE AP 34G.E.118-123  
MONORAIL INTERIEUR PARCLOSE PROFILE EN HAUT VAR 34G.E.123\_01.001-123\_01.002  
2-RAIL XQ 34G.E.124-129  
2-RAIL XX 34G.E.130-135  
2-RAIL XQX 34G.E.136-139  
2-RAIL QXQ 34G.E.140-143  
2-RAIL QXXXQ 34G.E.144-145  
2-RAIL XXXX 34G.E.146-149  
2-RAIL XQ CHICANE ETROITE 34G.E.150-151  
2-RAIL XQ AP 34G.E.152-157  
3-RAIL XXQ 34G.E.158-163  
3-RAIL XXX 34G.E.164-169  
3-RAIL QXXXXQ 34G.E.170-171  
3-RAIL XXXXXX 34G.E.172-173  
DORMANT DRAINAGE CACHE 34G.E.174-175  
VARIANTE OUVRANT VITRAGE EXTERIEUR 34G.E.175\_01.001-175

## Fabrication et montage

DIMENSIONS MAX. ADMISSIBLE CHICANE STANDARD 34G.F.001-021  
DIMENSIONS MAX. ADMISSIBLE CHICANE ETROITE 34G.F.022-038  
RENFORCEMENT TRAVERSE 34G.F.039  
ORDRE DE MONTAGE CADRE 34G.F.040-041  
MONTAGE BASE SUR PERFORMANCE 34G.F.041\_01.001-041\_01.002  
DRAINAGE MONORAIL INVERSION PARCLOSE 34G.F.042-073  
DRAINAGE MONORAIL VITRE PAR L'INTERIEUR 34G.F.074-095  
DRAINAGE 2-RAIL 34G.F.096-111  
DRAINAGE 3-RAIL 34G.F.112-123  
COUPER DE FERMETURE DORMANT 080,9738,04 34G.F.124-125  
COUPER DE FERMETURE DORMANT 080,9724,04/162,808 34G.F.126-127  
ASSEMBLAGE DU PROFILE SYNTHETIQUE DORMANT 406 34G.F.127\_01.001-127\_01.002  
PREPARATION DORMANT MONORAIL COTE SERRURE 34G.F.128  
ASSEMBLAGE DORMANT MONORAIL COTE SERRURE 34G.F.129  
PREPARATION DORMANT MONORAIL COTE FIXE 34G.F.130  
ASSEMBLAGE DORMANT MONORAIL COTE FIXE 34G.F.131  
PREPARATION DORMANT 2-RAIL 34G.F.132

ASSEMBLAGE DORMANT 2-RAIL 34G.F.133  
PREPARATION DORMANT 3-RAIL 34G.F.134-135  
ASSEMBLAGE DORMANT 3-RAIL 34G.F.136-137  
ASSEMBLAGE FERMETURE CHICANE OG 34G.F.138-139  
ASSEMBLAGE FERMETURE CHICANE IG 34G.F.140-141  
ASSEMBLAGE FERMETURE CHICANE 2-RAIL/3-RAIL 34G.F.142-143  
RACCORDEMENTS-T 34G.F.144-149\_01.002  
CADRE STANDARD CHICANE OG 34G.F.150-151  
CADRE CHICANE ETROITE OG 34G.F.152-153  
CADRE STANDARD CHICANE IG + OG VARIANTE 34G.F.154-155  
CADRE CHICANE ETROITE IG + OG VARIANTE 34G.F.156-157  
PREPARATION QXQ PROFILE 34G.F.158-159  
PREPARATION PROFILE DE RECouvreMENT QXQ 34G.F.160-161  
ASSEMBLAGE QXQ PROFILE 34G.F.162-163  
ASSEMBLAGE OUVRANT 34G.F.164-165  
PREPARATION CHICANE STANDARD 34G.F.166-167\_01.002  
PREPARATION CHICANE ETROITE 34G.F.168-169\_01.002  
DRAINAGE + DECOMPRESSION OUVRANT 34G.F.170-171  
DRAINAGE + DECOMPRESSION OUVRANT RENVERSE 34G.F.171\_01.001-171\_01.002  
FRAISAGE POUR DE GALETS 34G.F.172-177  
SERRURES (+KABA) 34G.F.178-179  
FRAISAGE POUR SERRURES 34G.F.180-181  
SERRURE CAPUCHONS 34G.F.182-183  
BEQUILLE APERCU 34G.F.184-185  
FRAISAGE BEQUILLES TOUCH 34G.F.186-193  
FRAISAGE BEQUILLES HORIZON 34G.F.194-201  
FRAISAGE BEQUILLES SIEGENIA 34G.F.202-207  
FRAISAGE BEQUILLES CONTOUR 34G.F.208-213  
FRAISAGE BEQUILLES PURITY 34G.F.214-219  
FRAISAGE BEQUILLES OLIMPO 34G.F.219\_01.001-219\_01.008  
MATRICE DE DECISION CYLINDRE 34G.F.220-221  
ASSEMBLAGE ANGULAIRE OUVRANT 34G.F.222-223  
ASSEMBLAGE EQUERRE A SERTIR 34G.F.224-225  
ASSEMBLAGE CHICANE STANDARD 34G.F.226-227  
ASSEMBLAGE CHICANE ETROITE 34G.F.228-229  
MONTAGE VANTAIL COULISSANT 34G.F.230  
ASSEMBLAGE ROULETTES 34G.F.231-231\_01.002  
ASSEMBLAGE SERRURE 34G.F.232  
ASSEMBLAGE POIGNEE 34G.F.233  
ASSEMBLAGE SERRURE AP 34G.F.234-235  
ASSEMBLAGE VENTAIL FIXES 2-RAIL 34G.F.236-237  
ASSEMBLAGE POIGNEE 062,6649,XX 34G.F.238  
ASSEMBLAGE POIGNEE A CUVETTE 34G.F.239  
PIECE DE SUPPORT OUVRANT FIXE 34G.F.240-243  
ASSEMBLAGE PIECES D'ECARTEMENT 34G.F.244-245  
SUPPORTS CALE DE VITRAGE 34G.F.246-255  
TABLEAU DE VITRAGE 34G.F.256-257  
TABLEAU DE VITRAGE CHICANE ETROITE 34G.F.258-259  
SUPPORT CALE DE VITRAGE SUPPLEMENTAIRE 34G.F.260  
COLLER VITRAGE CHICANE ETROITE 34G.F.261  
MONTAGE 34G.F.262-263  
ASSEMBLAGE PIECE DE BLOCAGE 34G.F.264-265  
MONTAGE RECEPTEUR 34G.F.266-269  
JOINDRE POINTS DE VERROUILLAGE 34G.F.270-271  
BUTEE 34G.F.272-277  
MONTAGE 4 VANTAUX VANTAIL 34G.F.278-279  
MONTAGE RECEPTEUR 4 VANTAUX VANTAIL 34G.F.280-281  
PROFILES DE RENFORCEMENT 34G.F.282-285  
D'ETANCHEITE VARIANT 34G.F.286-287  
ASSEMBLAGE AP 34G.F.288-293  
PROFILE DE FINITION 34G.F.294-299  
SAFETY DEVICE 34G.F.299\_01.001-299\_01.008  
POSITION PRESCRIT DE L'EXTENSION DU PROFIL DESSOUS: 34G.F.300-303  
PIECES DE RACCORDEMENT 34G.F.304-309  
PIECES DE RACCORDEMENT COIN 34G.F.310-313  
COMBINAISONS AVEC D'AUTRES SYSTEMES 34G.F.314-329  
PROFILE DE DILATATION 34G.F.330-331  
GARDE-CORPS 34G.F.332-333  
GOUTTIERE 34G.F.334-335  
RACCORDEMENT AU BATIMENT 34G.F.336-339  
CONTACT MAGNETIQUE 34G.F.340-345  
MOTEUR FRAISAGE DORMANT SUPERIEUR ACCESSOIRES 34G.F.345\_01.001-345\_01.018  
MOTEUR FRAISAGE+ASSEMBLAGE ACCESSOIRES 34G.F.345\_01.019-345\_01.043

## Accessoires

APERCU 34G.G.001  
EQUERRES 34G.G.002  
EQUERRE ANGLE VERRE 34G.G.003  
EQUERRES 34G.G.004  
JONCTIONS-T 34G.G.005-005\_01.002  
FERMETURE 34G.G.006-008  
JOINT / PIECE DE REMPLISSAGE ISOLEE 34G.G.009-010  
FERMETURE 34G.G.011-012  
FERMETURE AVEC BROSEE 34G.G.013  
SUPPORT CALE DE VITRAGE 34G.G.017  
JOINTS 34G.G.015-017  
JOINT DE VITRAGE 34G.G.018-021  
JOINTS-BROSSE 34G.G.022  
ACCESSOIRES GENERAUX 34G.G.023-028  
ACCESSOIRES PROTECTION ANTI-VOL 34G.G.029  
PIECES FINALES 34G.G.030  
PIECE FINALE 34G.G.031-033  
PIECE DE RACCORDEMENT 34G.G.034  
SERRURES 34G.G.035-037  
CYLINDRES 34G.G.038  
ROULETTES 34G.G.039  
TOUCH BEQUILLES 34G.G.040-041  
BEQUILLES PURITY 34G.G.042-043  
BEQUILLES SOULEV. COULISSANT 34G.G.044-048  
BEQUILLES KABA 34G.G.049  
TIGE 34G.G.050  
APERCU SAFETY DEVICE 34G.G.050\_01.001  
BASE D'ANCRAGE 34G.G.051-052  
MATRICE GUIDEE 34G.G.053  
CALIBRES 34G.G.054-056  
OUTILLAGES 34G.G.057  
CONTACT MAGNETIQUE 34G.G.058  
MOTEUR 34G.G.058\_01.001-058\_01.011



## Content

TABLE OF CONTENTS 34G.001-008

## General Information

LIST OF SYMBOLS 34G.A.001-008

## General Information System

PROCESSING DATA 34G.B.001-040  
TECHNICAL INFORMATION 34G.B.041-072  
MOTORISED GENERAL INFORMATION: DECISION MATRIX 34G.B.072\_01.001-072\_01.004

## Profiles

LIST OF PROFILES 34G.C.001  
PROFILE OVERVIEW 34G.C.002-010  
OUTER FRAME MONORAIL BOTTOM 34G.C.011-013  
OUTER FRAME MONORAIL TOP 34G.C.014  
OUTER FRAME 2-RAIL BOTTOM/TOP 34G.C.015  
OUTER FRAME 3-RAIL BOTTOM/TOP 34G.C.016  
OUTER FRAME SIDE 34G.C.017-019  
SYNTHETIC PROFILE OUTER FRAME 34G.C.020  
COVERING PROFILE 34G.C.021-022  
VENT PROFILE 34G.C.023  
STANDARD MEETING SECTION 34G.C.024  
SLIM MEETING SECTION 34G.C.025  
ADDITIONAL PROFILES 34G.C.026-027  
GLAZING BEADS 34G.C.028-030  
GLAZING BEADS RC2 / RC3 34G.C.031-032  
GLAZING BEADS 34G.C.033-034  
RAIL 34G.C.035  
REINFORCEMENT PROFILES 34G.C.036-038  
FINISHING PROFILE 34G.C.039  
CHANGEOVER PROFILE 34G.C.040  
CONNECTION PROFILE 34G.C.041-042  
TRANSOM-MULLION REINFORCED 34G.C.043  
CONNECTION PROFILE 34G.C.044  
EXPANSION PROFILE 34G.C.045  
Z-PROFILE 34G.C.046-048  
SHUTTER GUIDE 34G.C.049-051  
WALL FINISHING PROFILE 34G.C.052  
SUPPORTING PROFILE 34G.C.053  
GUTTER 34G.C.054

## Work drawings

OVERVIEW CONFIGURATIONS 34G.E.001-003  
OVERVIEW MAGNETIC CONTACT 34G.E.004-005  
OVERVIEW MOTORIZED CONFIGURATIONS 34G.E.005\_01.001-005\_01.002  
OVERVIEW INSULATION VARIANTS 34G.E.006-049  
MONORAIL XQ OUTSIDE GLAZING 34G.E.050-055  
MONORAIL XQX OUTSIDE GLAZING 34G.E.056-059  
MONORAIL XQX OUTSIDE GLAZING 34G.E.060-063  
MONORAIL QXXQ OUTSIDE GLAZING 34G.E.064-065  
MONORAIL XQVQ OUTSIDE GLAZING OC 34G.E.066-071  
MONORAIL XQVQ OUTSIDE GLAZING IC 34G.E.072-075  
MONORAIL XQVQX OUTSIDE GLAZING OC 34G.E.076-077  
MONORAIL XQVQX OUTSIDE GLAZING IC 34G.E.078-079  
MONORAIL XQ OUTSIDE GLAZING SLIM CHICANE 34G.E.080-081  
MONORAIL OUTSIDE GLAZING VARIANT BOTTOM PROFIL 34G.E.082  
MONORAIL OUTSIDE GLAZING VARIANT TOP PROFILE 34G.E.083  
MONORAIL XQ OUTSIDE GLAZING AP 34G.E.084-089  
MONORAIL XQ INSIDE GLAZING 34G.E.090-095  
MONORAIL XQX INSIDE GLAZING 34G.E.096-099  
MONORAIL QXXQ INSIDE GLAZING 34G.E.100-101  
MONORAIL XQVQ INSIDE GLAZING OC 34G.E.102-107  
MONORAIL XQVQ INSIDE GLAZING IC 34G.E.108-111  
MONORAIL XQVQX INSIDE GLAZING OC 34G.E.112-113  
MONORAIL XQVQX INSIDE GLAZING IC 34G.E.114-115  
MONORAIL XQ INSIDE GLAZING SLIM CHICANE 34G.E.116-117  
MONORAIL XQ INSIDE GLAZING AP 34G.E.118-123  
MONORAIL INSIDE GLAZING VARIANT TOP PROFILE 34G.E.123\_01.001-123\_01.002  
2-RAIL XQ 34G.E.124-129  
2-RAIL XX 34G.E.130-135  
2-RAIL XQX 34G.E.136-139  
2-RAIL QXQ 34G.E.140-143  
2-RAIL QXXX 34G.E.144-145  
2-RAIL XXXX 34G.E.146-149  
2-RAIL XQ SLIM CHICANE 34G.E.150-151  
2-RAIL XQ AP 34G.E.152-157  
3-RAIL XXQ 34G.E.158-163  
3-RAIL XXX 34G.E.164-169  
3-RAIL QXXXXX 34G.E.170-171  
3-RAIL XXXXXX 34G.E.172-173  
OUTER FRAME HIDDEN DRAINAGE 34G.E.174-175  
VARIANT VENT OUTSIDE GLAZING 34G.E.175\_01.001-175

## Assembly drawings

MAX. ADMISSIBLE SIZES STANDARD CHICANE 34G.F.001-021  
MAX. ADMISSIBLE SIZES SLIM CHICANE 34G.F.022-038  
REINFORCEMENT T-PROFILE 34G.F.039  
ORDER OF ASSEMBLY FRAME 34G.F.040-041  
ASSEMBLY BASED ON PERFORMANCE 34G.F.041\_01.001-041\_01.002  
DRAINAGE MONORAIL OUTSIDE GLAZED 34G.F.042-073  
DRAINAGE MONORAIL INSIDE GLAZED 34G.F.074-095  
DRAINAGE 2-RAIL 34G.F.096-111  
DRAINAGE 3-RAIL 34G.F.112-123  
CUTTING OF CLOSER OUTER FRAME 080.9738.04 34G.F.124-125  
CUTTING OF CLOSER OUTER FRAME 080.9724.04/162.80E 34G.F.126-127  
ASSEMBLY OF SYNTHETIC PROFILE OUTER FRAME 406.00E 34G.F.127\_01.001-127\_01.002  
PREPARATION OUTER FRAME MONORAIL LOCK SIDE 34G.F.128  
ASSEMBLY OUTER FRAME MONORAIL LOCK SIDE 34G.F.129  
PREPARATION OUTER FRAME MONORAIL FIXED SIDE 34G.F.130  
ASSEMBLY OUTER FRAME MONORAIL FIXED SIDE 34G.F.131  
PREPARATION OUTER FRAME 2-RAIL 34G.F.132

ASSEMBLY OUTER FRAME 2-RAIL 34G.F.133  
PREPARATION OUTER FRAME 3-RAIL 34G.F.134-135  
ASSEMBLY OUTER FRAME 3-RAIL 34G.F.136-137  
ASSEMBLY CLOSER CHICANE OG 34G.F.138-139  
ASSEMBLY CLOSER CHICANE IG 34G.F.140-141  
ASSEMBLY CLOSER CHICANE 2-RAIL/3-RAIL 34G.F.142-143  
T-CONNECTIONS 34G.F.144-149\_01.002  
FRAME STANDARD CHICANE OG 34G.F.150-151  
FRAME SLIM CHICANE OG 34G.F.152-153  
FRAME STANDARD CHICANE IG + OG VARIANT 34G.F.154-155  
FRAME SLIM CHICANE IG + OG VARIANTE 34G.F.156-157  
PREPARATION OXQ PROFILE 34G.F.158-159  
PREPARATION COVERING PROFILE 34G.F.160-161  
ASSEMBLY OXQ PROFILE 34G.F.162-163  
ASSEMBLY VENT 34G.F.164-165  
PREPARATION STANDARD CHICANE 34G.F.166-167\_01.002  
PREPARATION SLIM CHICANE 34G.F.168-169\_01.002  
DRAINAGE + DECOMPRESSION VENT 34G.F.170-171  
DRAINAGE + DECOMPRESSION REVERSED VENT 34G.F.171\_01.001-171\_01.002  
MILLING FOR ROLLERS 34G.F.172-177  
LOCKS (+KABA) 34G.F.178-179  
MILLING FOR LOCKS 34G.F.180-181  
LOCK COVER 34G.F.182-183  
HANDLE OVERVIEW 34G.F.184-185  
MILLING DOOR HANDLES TOUCH 34G.F.186-193  
MILLING DOOR HANDLES HORIZON 34G.F.194-201  
MILLING DOOR HANDLES SIEGENIA 34G.F.202-207  
MILLING DOOR HANDLES CONTOUR 34G.F.208-213  
MILLING DOOR HANDLES PURITY 34G.F.214-219  
MILLING DOOR HANDLES OLIMPO 34G.F.219\_01.001-219\_01.008  
DECISION MATRIX CYLINDER 34G.F.220-221  
CORNER CONNECTION VENT 34G.F.222-223  
CONNECTION CRIMP CORNER CLEAT 34G.F.224-225  
ASSEMBLY STANDARD CHICANE 34G.F.226-227  
ASSEMBLY SLIM CHICANE 34G.F.228-229  
ASSEMBLY SLIDING VENT 34G.F.230  
ASSEMBLY CARRIAGE 34G.F.231-231\_01.002  
ASSEMBLY LOCK 34G.F.232  
ASSEMBLY HANDLE 34G.F.233  
ASSEMBLY LOCK AP 34G.F.234-235  
ASSEMBLY FIXED VENT 2-RAIL 34G.F.236-237  
ASSEMBLY HANDLE 062.6649.XX 34G.F.238  
ASSEMBLY CUP HANDLE 34G.F.239  
SUPPORTING PIECE FIXED VENT 34G.F.240-243  
ASSEMBLY DISTANCE PIECES 34G.F.244-245  
GLASS SUPPORTS 34G.F.246-255  
GLAZING TABLE 34G.F.256-257  
GLAZING TABLE SLIM CHICANE 34G.F.258-259  
ADDITIONAL GLASS SUPPORT 34G.F.260  
GLUE GLASS SLIM CHICANE 34G.F.261  
ASSEMBLY 34G.F.262-263  
ASSEMBLY FIXING PIECE 34G.F.264-265  
ASSEMBLY RECEIVER 34G.F.266-269  
ADJUSTMENT LOCKING POINTS 34G.F.270-271  
BUFFER 34G.F.272-277  
ASSEMBLY 4 DOORS VENT 34G.F.278-279  
ASSEMBLY RECEIVER 4 DOORS VENT 34G.F.280-281  
REINFORCEMENT PROFILES 34G.F.282-285  
VARIANT SEALING 34G.F.286-287  
ASSEMBLY AP 34G.F.288-293  
FINISHING PROFILE 34G.F.294-299  
SAFETY DEVICE 34G.F.299\_01.001-299\_01.008  
PRESCRIBED POSITION OF THE BOTTOM EXTENSION 34G.F.300-303  
CONNECTION PIECES 34G.F.304-309  
CONNECTION PIECES CORNER 34G.F.310-313  
CONNECTIONS WITH OTHER SYSTEMS 34G.F.314-329  
EXPANSION PROFILE 34G.F.330-331  
BALUSTRADE 34G.F.332-333  
GUTTER 34G.F.334-335  
BUILDING CONNECTION 34G.F.336-339  
MAGNETIC CONTACT 34G.F.340-345  
MOTOR MILLING TOP PROFILE ACCESSORIES 34G.F.345\_01.001-345\_01.018  
MOTOR MILLINGS+ASSEMBLY ACCESSORIES 34G.F.345\_01.019-345\_01.043

## Accessories

OVERVIEW 34G.G.001  
CORNER CLEATS 34G.G.002  
CORNER CLEAT GLASS CORNER 34G.G.003  
CORNER CLEATS 34G.G.004  
T-BRACKETS 34G.G.005-005\_01.002  
CLOSER 34G.G.006-008  
GASKET / FILLING PIECE INSULATING 34G.G.009-010  
CLOSER 34G.G.011-012  
CLOSER WITH BRUSH 34G.G.013  
GLASS SUPPORT 34G.G.014  
GASKETS 34G.G.015-017  
GLAZING GASKET 34G.G.018-021  
BRUSHES 34G.G.022  
GENERAL ACCESSORIES 34G.G.023-028  
ACCESSORIES BURGLAR PROTECTION 34G.G.029  
END PIECES 34G.G.030  
END PIECE 34G.G.031-033  
CONNECTION PIECE 34G.G.034  
LOCKS 34G.G.035-037  
CYLINDERS 34G.G.038  
ROLLERS 34G.G.039  
TOUCH DOOR HANDLES 34G.G.040-041  
DOOR HANDLES PURITY 34G.G.042-043  
DOOR HANDLES LIFT AND SLIDING DOOR 34G.G.044-048  
DOOR HANDLES KABA 34G.G.049  
SPINDLE 34G.G.050  
OVERVIEW SAFETY DEVICE 34G.G.050\_01.001  
PART ANCHOR 34G.G.051-052  
PUNCH TOOL 34G.G.053  
BORING JIGS 34G.G.054-056  
TOOLS 34G.G.057  
MAGNETIC CONTACT 34G.G.058  
MOTOR 34G.G.058\_01.001-058\_01.011



## Inhalt

INHALTSANGABE 34G.001-008

## Allgemeine Information

ZEICHENERKLAERUNG 34G.A.001-008

## Allgemeine Information Systeme

VERARBEITUNGSVORSCHRIFTEN 34G.B.001-040  
TECHNISCHE INFORMATION 34G.B.041-072  
MOTORISIERTER ALLGEMEINE INFORMATION: ENTSCHEID 34G.B.072\_01.001-072\_01.004

## Profile

PROFILLISTE 34G.C.001  
PROFILUEBERSICHT 34G.C.002-010  
BLENDRAHMEN MONORAIL UNTEN 34G.C.011-013  
BLENDRAHMEN MONORAIL ABDICHTUNG OBEN 34G.C.014  
BLENDRAHMEN 2-RAIL UNTEN/OBEN 34G.C.015  
BLENDRAHMEN 3-RAIL UNTEN/OBEN 34G.C.016  
BLENDRAHMEN SENKRECHT 34G.C.017-019  
KUNSTSTOFFPROFIL BLENDRAHMEN 34G.C.020  
ABDECKPROFIL 34G.C.021-022  
FLUEGELPROFIL 34G.C.023  
STANDARD WECHSELPROFIL 34G.C.024  
SCHMAL WECHSELPROFIL 34G.C.025  
ZUSATZPROFILE 34G.C.026-027  
GLASLEISTEN 34G.C.028-030  
GLASLEISTEN RC2 / RC3 34G.C.031-032  
GLASLEISTEN 34G.C.033-034  
RAIL 34G.C.035  
VERSTAERKUNGSPROFILE 34G.C.036-038  
AUSFUEHRUNGSPROFIL 34G.C.039  
WECHSELPROFIL 34G.C.040  
KUPPLUNGSPROFIL 34G.C.041-042  
SPROSSE VERSTAERKT 34G.C.043  
KUPPLUNGSPROFIL 34G.C.044  
AUSDEHNUNGSPROFIL 34G.C.045  
Z-PROFIL 34G.C.046-048  
ROLLADENFUEHRUNG 34G.C.049-051  
AUSFUEHRUNGSPROFIL 34G.C.052  
STUETZPROFIL 34G.C.053  
RINNENPROFIL 34G.C.054

## Werkzeichnungen

UEBERSICHT KONFIGURATIONEN 34G.E.001-003  
UEBERSICHT MAGNETKONTAKTE 34G.E.004-005  
UEBERSICHT MOTORISIERTER KONFIGURATIONEN 34G.E.005\_01.001-005\_01.002  
UEBERSICHT ISOLIERVARIANTEN 34G.E.006-049  
MONORAIL XQ AUSSENVERGLASUNG 34G.E.050-055  
MONORAIL QXQ AUSSENVERGLASUNG 34G.E.056-059  
MONORAIL QXQ AUSSENVERGLASUNG 34G.E.060-063  
MONORAIL QXXQ AUSSENVERGLASUNG 34G.E.064-065  
MONORAIL XQVQ OUTSIDE GLAZING OC 34G.E.066-071  
MONORAIL XQVQ AUSSENVERGLASUNG IC 34G.E.072-075  
MONORAIL XQVQX AUSSENVERGLASUNG OC 34G.E.076-077  
MONORAIL XQVQX AUSSENVERGLASUNG IC 34G.E.078-079  
MONORAIL XQ AUSSENVERGLASUNG SCHMALE SCHIKA 34G.E.080-081  
MONORAIL AUSSENVERGLASUNG VARIANTE UNTEN PRC 34G.E.082  
MONORAIL AUSSENVERGLASUNG VARIANTE OBEN PROI 34G.E.083  
MONORAIL XQ AUSSENVERGLASUNG AP 34G.E.084-089  
MONORAIL XQ INNENGLASUNG 34G.E.090-095  
MONORAIL QXQ INNENGLASUNG 34G.E.096-099  
MONORAIL QXXQ INNENGLASUNG 34G.E.100-101  
MONORAIL XQVQ INNENGLASUNG OC 34G.E.102-107  
MONORAIL XQVQ INNENGLASUNG IC 34G.E.108-111  
MONORAIL XQVQX INNENGLASUNG IC 34G.E.112-113  
MONORAIL XQVQX INNENGLASUNG OC 34G.E.114-115  
MONORAIL XQ INNENGLASUNG SCHMALE SCHIKANE 34G.E.116-117  
MONORAIL XQ INNENGLASUNG AP 34G.E.118-123  
MONORAIL INNENGLASUNG VARIANTE OBEN PROFILE 34G.E.123\_01.001-123\_01.002  
2-RAIL XQ 34G.E.124-129  
2-RAIL XX 34G.E.130-135  
2-RAIL QXQ 34G.E.136-139  
2-RAIL QXQ 34G.E.140-143  
2-RAIL QXXXQ 34G.E.144-145  
2-RAIL XXXX 34G.E.146-149  
2-RAIL XQ SCHMALE SCHIKANE 34G.E.150-151  
2-RAIL XQ AP 34G.E.152-157  
3-RAIL XXQ 34G.E.158-163  
3-RAIL XXX 34G.E.164-169  
3-RAIL QXXXXQ 34G.E.170-171  
3-RAIL XXXXXX 34G.E.172-173  
BLENDRAHMEN VERDECKTER ENTWASSERUNG 34G.E.174-175  
VARIANTE FLUEGEL AUSSENVERGLASUNG 34G.E.175\_01.001-175

## Montagezeichnungen







MAX. ZULAESSIGE ABMESSUNGEN STANDARD SCHIKAN 34G.F.001-021  
MAX. ZULAESSIGE ABMESSUNGEN SCHMALE SCHIKANE 34G.F.022-038  
VERSTAERKUNGSSPOSSE 34G.F.039  
REIHENFOLGE VON MONTAGE BLENDRAHMEN 34G.F.040-041  
MONTAGE BEZOGEN AUF AUSFUHRUNG 34G.F.041\_01.001-041\_01.002  
ENTWASSERUNG MONORAIL AUSSENVERGLASUNG 34G.F.042-073  
ENTWASSERUNG MONORAIL INNENVERGLASUNG 34G.F.074-095  
ENTWASSERUNG 2-RAIL 34G.F.096-111  
ENTWASSERUNG 3-RAIL 34G.F.112-123  
SCNEIDEN VON ABDICHTUNG BLENDRAHMEN 0809738 34G.F.124-125  
SCNEIDEN VON ABDICHTUNG BLENDRAHMEN 0809724 34G.F.126-127  
MONTAGE KUNSTSTOFFPROFIL BLENDRAHMEN 406.032 34G.F.127\_01.001-127\_01.002  
VORBREITUNG BLENDRAHMEN MONORAIL VERRIEGELU 34G.F.128  
MONTAGE BLENDRAHMEN MONORAIL VERRIEGELUNGS 34G.F.129  
VORBREITUNG BLENDRAHMEN MONORAIL FESTE SEITE 34G.F.130  
MONTAGE BLENDRAHMEN MONORAIL FESTE SEITE 34G.F.131  
VORBREITUNG BLENDRAHMEN 2-RAIL 34G.F.132















MONTAGE BLENDRAHMEN 2-RAIL 34G.F.133  
VORBREITUNG BLENDRAHMEN 3-RAIL 34G.F.134-135  
MONTAGE BLENDRAHMEN 3-RAIL 34G.F.136-137  
MONTAGE ABDICHTUNG CHICANE OG 34G.F.138-139  
MONTAGE ABDICHTUNG CHICANE IG 34G.F.140-141  
MONTAGE ABDICHTUNG CHICANE 2-RAIL/3-RAIL 34G.F.142-143  
T-VERBINDUNGEN 34G.F.144-149\_01.002  
RAHMEN STANDARD CHICANE OG 34G.F.150-151  
RAHMEN SCHMALE CHICANE OG 34G.F.152-153  
RAHMEN STANDARD CHICANE IG + OG VARIANTE 34G.F.154-155  
RAHMEN SCHMALE CHICANE IG + OG VARIANT 34G.F.156-157  
VORBREITUNG QXQ PROFIL 34G.F.158-159  
VORBREITUNG ABDECKPROFIL QXQ 34G.F.160-161  
MONTAGE QXQ PROFIL 34G.F.162-163  
MONTAGE FLUEGEL 34G.F.164-165  
VORBREITUNG STANDARD SCHIKANE 34G.F.166-167\_01.002  
VORBREITUNG SCHMALE SCHIKANE 34G.F.168-169\_01.002  
ENTWASSERUNG + DECOMPRESSION FLUEGEL 34G.F.170-171  
ENTWASSERUNG + DECOMPRESSION UMGEKEHRTE FL 34G.F.171\_01.001-171\_01.002  
AUSFRAESUNG FUR LAUFRAD 34G.F.172-177  
SCHLOESSER (+KABA) 34G.F.178-179  
AUSFRAESUNG FUER SCHLOESSER 34G.F.180-181  
ABDECKKAP HAKENSCHLOSS 34G.F.182-183  
GRIFF UBERSICHT 34G.F.184-185  
AUSFRAESUNG TUERDRUECKER TOUCH 34G.F.186-193  
AUSFRAESUNG TUERDRUECKER HORIZON 34G.F.194-201  
AUSFRAESUNG TUERDRUECKER SIEGENIA 34G.F.202-207  
AUSFRAESUNG TUERDRUECKER CONTOUR 34G.F.208-213  
AUSFRAESUNG TUERDRUECKER PURITY 34G.F.214-219  
AUSFRAESUNG TUERDRUECKER OLIMPO 34G.F.219\_01.001-219\_01.008  
ENTSCHEIDUNGSMATRIX ZYLINDER 34G.F.220-221  
ECKVERBINDUNG FLUEGEL 34G.F.222-223  
VERBINDUNG PRESSECKWINKEL 34G.F.224-225  
MONTAGE STANDARD SCHIKANE 34G.F.226-227  
MONTAGE SCHMALE SCHIKANE 34G.F.228-229  
MONTAGE SCHIEBEFLUEGEL 34G.F.230  
MONTAGE LAUFWAGEN 34G.F.231-231\_01.002  
MONTAGE SCHLOSS 34G.F.232  
MONTAGE GRIFF 34G.F.233  
MONTAGE SCHLOSS AP 34G.F.234-235  
MONTAGE FENSTER FLUEGEL 2-RAIL 34G.F.236-237  
MONTAGE HANDGRIFF 062.6649.XX 34G.F.238  
MONTAGE SCHALENGRIFF 34G.F.239  
STUETZKLOTZ FESTEN FLUEGEL 34G.F.240-243  
MONTAGE DISTANZSTUECKE 34G.F.244-245  
KLOTZBRUECKEN 34G.F.246-255  
VERGLASUNGSTABELLE 34G.F.256-257  
VERGLASUNGSTABELLE SCHMALE SCHIKANE 34G.F.258-259  
ZUSATZLICHES GLASAUFLAGEPROFIL 34G.F.260  
VERKLEBEN GLAS SCHMALE SCHIKANE 34G.F.261  
MONTAGE 34G.F.262-263  
MONTAGE BEFESTIGUNGSKLOTZ 34G.F.264-265  
MONTAGE EMPFANGER 34G.F.266-269  
EINSTELLEN DER SCHLIESSPUNKTE 34G.F.270-271  
STOPPER 34G.F.272-277  
MONTAGE 4-SCHLAG FLUEGEL 34G.F.278-279  
MONTAGE EMPFANGER 4-SCHLAG FLUEGEL 34G.F.280-281  
VERSTAERKUNGSPROFILE 34G.F.282-285  
VARIANTE DICHTUNG 34G.F.286-287  
MONTAGE AP 34G.F.288-293  
AUSFUEHRUNGSPROFIL 34G.F.294-299  
SAFETY DEVICE 34G.F.299\_01.001-299\_01.008  
FESTGESETZTE POSITION VERLAENGUNG UNDERRIEGEL 34G.F.300-303  
KOPPLUNGSSTUECKE 34G.F.304-309  
OPPLUNGSSTUECKE WINKEL 34G.F.310-313  
KOMBINATIONEN MIT ANDEREN SYSTEMEN 34G.F.314-329  
AUSDEHNUNGSPROFIL 34G.F.330-331  
GELAEENDER 34G.F.332-333  
RINNENPROFIL 34G.F.334-335  
BAUANSCHLUSS 34G.F.336-339  
MAGNETKONTAKTE 34G.F.340-345  
ANTRIEB AUSFRAESUNG OBERER BLENDRAHMEN BESCH 34G.F.345\_01.001-345\_01.018  
AUSFRAESUNG+MONTAGE BESCHLAG ANTRIEB 34G.F.345\_01.019-345\_01.043







## Zubehoer

UEBERSICHT 34G.G.001  
ECKWINKEL 34G.G.002  
ECKVERBINDER GLASECKE 34G.G.003  
ECKWINKEL 34G.G.004  
T-VERBINDER 34G.G.005-005\_01.002  
ABDICHTUNG 34G.G.006-008  
DICHTUNG / FUELLSTUECK ISOLIEREND 34G.G.009-010  
ABDICHTUNG 34G.G.011-012  
ABDICHTUNG MIT BUERSTE 34G.G.013  
GLASAUFLAGEPROFIL 34G.G.014  
DICHTUNGEN 34G.G.015-017  
VERGLASUNGSDICHTUNG 34G.G.018-021  
BUEKSTENDICHTUNGEN 34G.G.022  
ALLGEMEINES ZUBEHOER 34G.G.023-028  
ZUBEHOER EINBRUCHHEMMEND 34G.G.029  
ENDKAPPEN 34G.G.030  
ENDSTUECK 34G.G.031-033  
KUPPLUNGSSTUECK 34G.G.034  
SCHLOESSER 34G.G.035-037  
ZYLINDER 34G.G.038  
LAUFWAGEN 34G.G.039  
TOUCH TUERDRUECKERS 34G.G.040-041  
TUERDRUECKER PURITY 34G.G.042-043  
TUERDRUECKER HEBESCHIEBETUER 34G.G.044-048  
TUERDRUECKER KABA 34G.G.049  
DRUCKERSTIFT 34G.G.050  
UEBERSICHT SAFETY DEVICE 34G.G.050\_01.001  
EINDREHANKER 34G.G.051-052  
STANZWERKZEUG 34G.G.053  
BOHRLERHREN 34G.G.054-056  
WERKZEUGE 34G.G.057  
MAGNETKONTAKTE 34G.G.058  
ANTRIEB 34G.G.058\_01.001-058\_01.011

					
34G.A.001	08/07/2022	D0099740	34G.C.051	16/05/2022	D2001728
34G.A.002	10/2021	D0099741	34G.C.052	16/05/2022	D0099428
34G.A.003	10/2021	D0099742	34G.C.053	10/2021	D3007545
34G.A.004	10/2021	D0099743	34G.C.054	27/10/2021	D3009047
34G.A.005	10/2021	D0099744	34G.E.001	10/2021	
34G.A.006	10/2021	D0099745	34G.E.002	04/02/2022	D3005940
34G.A.007	10/2021	D0099746	34G.E.004	10/12/2021	D3008559
34G.A.008	10/2021		34G.E.005_01.001	18/10/2022	D3009334
34G.B.001	10/2021	pd.089.g34a.00-du	34G.E.006	27/10/2021	D3006253
34G.B.011	10/2021	pd.089.g34a.00-fr	34G.E.008	10/2021	D3006257
34G.B.021	10/2021	pd.089.g34a.00-en	34G.E.010	10/12/2021	D3006258
34G.B.031	10/2021	pd.089.g34a.00-ge	34G.E.011_01.001	18/10/2022	D3009501
34G.B.041	10/2021	ti.089.g34a.00-du	34G.E.012	10/2021	D3006259
34G.B.049	10/2021	ti.089.g34a.00-fr	34G.E.014	10/2021	D3006260
34G.B.057	10/2021	ti.089.g34a.00-en	34G.E.016	27/10/2021	D3009017
34G.B.065	10/2021	ti.089.g34a.00-ge	34G.E.018	10/2021	D3008195
34G.B.072_01.001	18/10/2022	D3009105	34G.E.020	27/10/2021	D3006261
34G.B.072_01.002	18/10/2022	D3009108	34G.E.022	14/12/2021	D3006262
34G.B.072_01.003	18/10/2022	D3008893	34G.E.024	10/2021	D3006263
34G.B.072_01.004			34G.E.025_01.001	18/10/2022	D3009502
34G.C.001	10/2021		34G.E.026	10/2021	D3006264
34G.C.002	20/04/2022	D3005927	34G.E.028	10/2021	D3006265
34G.C.003	27/10/2021	D3005928	34G.E.030	27/10/2021	D3009018
34G.C.004	11/01/2022	D3006987	34G.E.032	27/10/2021	D3006266
34G.C.005	10/2021	D3005930	34G.E.034	10/2021	D3006267
34G.C.006	10/2021	D3005931	34G.E.036	10/2021	D3009019
34G.C.007	10/2021	D3005932	34G.E.038	10/2021	D3009020
34G.C.008	10/2021	D3005929	34G.E.040	10/2021	D3009021
34G.C.009	10/2021	D3006096	34G.E.042	10/2021	D3009022
34G.C.010	27/10/2021	D3006097	34G.E.044	27/10/2021	D3009023
34G.C.011	05/05/2022	D3005897	34G.E.046	10/2021	D3009024
34G.C.012	05/05/2022	D3008177	34G.E.048	10/2021	D3009025
34G.C.013	05/05/2022	D3005900	34G.E.050	27/10/2021	D3006176
34G.C.014	04/02/2022	D3005898	34G.E.052	10/2021	D3006177
34G.C.015	05/05/2022	D3005899	34G.E.054	04/02/2022	D3006179
34G.C.016	05/05/2022	D3009028	34G.E.056	10/2021	D3006180
34G.C.017	05/05/2022	D3005901	34G.E.058	04/02/2022	D3006181
34G.C.018	05/05/2022	D3008179	34G.E.060	10/2021	D3008889
34G.C.019	05/05/2022	D3009029	34G.E.062	10/12/2021	D3008891
34G.C.020	21/04/2022	D3005902	34G.E.064	04/02/2022	D3006182
34G.C.021	05/05/2022	D3005905	34G.E.066	10/2021	D3006183
34G.C.022	21/04/2022	D3005903	34G.E.068	10/2021	D3006471
34G.C.023	07/06/2022	D3005906	34G.E.070	04/02/2022	D3006185
34G.C.024	07/06/2022	D3005907	34G.E.072	10/2021	D3006187
34G.C.025	07/06/2022	D3005908	34G.E.074	04/02/2022	D3006188
34G.C.026	11/01/2022	D3005904	34G.E.076	04/02/2022	D3006189
34G.C.027	11/01/2022	D3009041	34G.E.078	04/02/2022	D3006190
34G.C.028	10/05/2022	D2000901	34G.E.080	13/10/2022	D3006191
34G.C.029	10/05/2022	D2000903	34G.E.082	21/04/2022	D3009195
34G.C.030	10/05/2022	D0101168	34G.E.084	27/10/2021	D3007737
34G.C.031	10/05/2022	D0099930	34G.E.086	10/2021	D3007738
34G.C.032	10/05/2022	D0099934	34G.E.088	29/11/2021	D3007739
34G.C.033	10/2021	D3005923	34G.E.090	27/10/2021	D3006192
34G.C.034	10/05/2022	D2001507	34G.E.092	10/2021	D3006193
34G.C.035	10/2021	D3005909	34G.E.094	04/02/2022	D3006195
34G.C.036	13/10/2022	D3005910	34G.E.096	10/2021	D3006196
34G.C.037	10/2021	D3005911	34G.E.098	04/02/2022	D3006197
34G.C.038	05/05/2022	D3005912	34G.E.100	04/02/2022	D3006198
34G.C.039	04/02/2022	D3005913	34G.E.102	10/2021	D3006199
34G.C.040	10/2021	D3006032	34G.E.104	10/2021	D3006474
34G.C.041	10/2021	D3005926	34G.E.106	04/02/2022	D3006200
34G.C.042	10/2021	D3006033	34G.E.108	10/2021	D3006213
34G.C.043	08/04/2022	D3006650	34G.E.110	04/02/2022	D3006214
34G.C.044	10/2021	D3006035	34G.E.112	04/02/2022	D3006216
34G.C.045	05/05/2022	D3003604	34G.E.114	04/02/2022	D3006217
34G.C.046	05/05/2022	D0098846	34G.E.116	13/10/2022	D3006218
34G.C.047	05/05/2022	D0101159	34G.E.118	27/10/2021	D3007742
34G.C.048	05/05/2022	D0098847	34G.E.120	10/2021	D3007744
34G.C.049	16/05/2022	D0099430	34G.E.122	10/2021	D3008061
34G.C.050	16/05/2022	D0099429	34G.E.123_01.001	18/10/2022	D3009668

					
34G.E.124	10/2021	D3006220	34G.F.080	10/2021	D3006276
34G.E.126	27/10/2021	D3006221	34G.F.082	10/2021	D3007016
34G.E.128	13/10/2022	D3006222	34G.F.084	10/2021	D3006277
34G.E.130	10/2021	D3006223	34G.F.086	10/2021	D3006278
34G.E.132	10/2021	D3006224	34G.F.088	10/2021	D3007018
34G.E.134	13/10/2022	D3006225	34G.F.090	10/2021	D3006219
34G.E.136	27/10/2021	D3006228	34G.F.092	10/2021	D3007476
34G.E.138	13/10/2022	D3006229	34G.F.094	10/2021	D3007019
34G.E.140	27/10/2021	D3008885	34G.F.096	10/2021	D3006227
34G.E.142	10/12/2021	D3008887	34G.F.098	10/2021	D3006241
34G.E.144	13/10/2022	D3006230	34G.F.100	04/08/2022	D3008919
34G.E.146	10/2021	D3006231	34G.F.102	04/08/2022	D3008920
34G.E.148	10/2021	D3006233	34G.F.104	10/2021	D3006254
34G.E.150	10/2021	D3006234	34G.F.106	10/2021	D3006232
34G.E.152	27/10/2021	D3007745	34G.F.108	10/2021	D3007478
34G.E.154	27/10/2021	D3007747	34G.F.110	10/2021	D3007020
34G.E.156	10/2021	D3007749	34G.F.112	10/2021	D3008914
34G.E.158	10/2021	D3008867	34G.F.114	10/2021	D3008932
34G.E.160	10/2021	D3008869	34G.F.116	10/2021	D3008971
34G.E.162	27/10/2021	D3008870	34G.F.118	10/2021	D3008972
34G.E.164	10/2021	D3008880	34G.F.120	14/12/2021	D3008933
34G.E.166	10/2021	D3008881	34G.F.122	14/12/2021	D3008935
34G.E.168	29/11/2021	D3008882	34G.F.124	13/10/2022	D3007057
34G.E.170	17/11/2021	D3008937	34G.F.126	10/2021	D3008585
34G.E.172	29/11/2021	D3008945	34G.F.127_01.001	18/10/2022	D3011093
34G.E.174	30/05/2022	D3006321	34G.F.128	20/10/2021	D3006109
34G.E.175_01.001	18/10/2022	D3010657	34G.F.130	20/10/2021	D3006128
34G.E.176	10/2021		34G.F.132	20/10/2021	D3006103
34G.F.001	10/2021		34G.F.134	10/2021	D3008906
34G.F.002	10/2021	D3006490	34G.F.136	20/10/2021	D3008913
34G.F.004	10/2021	D3006493	34G.F.138	20/10/2021	D3006279
34G.F.006	10/2021	D3006494	34G.F.140	20/10/2021	D3006288
34G.F.007_01.001	18/10/2022	D3009525	34G.F.142	20/10/2021	D3006294
34G.F.008	10/2021	D3006495	34G.F.144	05/11/2021	D3006649
34G.F.010	10/2021	D3006496	34G.F.146	20/10/2021	D3007148
34G.F.012	10/2021	D3006501	34G.F.148	10/2021	D3008725
34G.F.014	10/2021	D3006502	34G.F.149_01.001	18/10/2022	D3009833
34G.F.016	10/2021	D3006504	34G.F.150	27/10/2021	D3006174
34G.F.018	10/2021	D3006507	34G.F.152	22/08/2022	D3006175
34G.F.020	10/2021	D3006509	34G.F.154	27/10/2021	D3006134
34G.F.022	10/2021	D3006513	34G.F.156	27/10/2021	D3006142
34G.F.024	10/2021	D3006514	34G.F.158	10/12/2021	D3008965
34G.F.026	10/2021	D3006516	34G.F.160	10/2021	D3008967
34G.F.028	10/2021	D3006517	34G.F.162	03/11/2021	D3008969
34G.F.030	10/2021	D3006518	34G.F.164	04/02/2022	D3006628
34G.F.032	10/2021	D3006521	34G.F.166	27/10/2021	D3006137
34G.F.034	10/2021	D3006522	34G.F.167_01.001	18/10/2022	D3009503
34G.F.036	10/2021	D3006524	34G.F.168	04/11/2021	D3006151
34G.F.038	07/06/2022	D3006526	34G.F.169_01.001	18/10/2022	D3009504
34G.F.040	20/10/2021	D3006620	34G.F.170	26/04/2022	D3006364
34G.F.041_01.001	18/10/2022	D3010512	34G.F.171_01.001	18/10/2022	D3010655
34G.F.042	10/2021	D3006186	34G.F.172	10/2021	D3006352
34G.F.044	10/2021	D3006235	34G.F.174	10/2021	D3006361
34G.F.046	04/08/2022	D3008915	34G.F.176	02/11/2021	D3009080
34G.F.048	04/08/2022	D3008916	34G.F.178	22/12/2021	D3006400
34G.F.050	10/2021	D3006236	34G.F.180	10/2021	D3006362
34G.F.052	10/2021	D3006237	34G.F.182	20/10/2021	D3006389
34G.F.054	10/2021	D3007012	34G.F.184	24/03/2022	D3008552
34G.F.056	10/2021	D3006268	34G.F.186	10/2021	D3006407
34G.F.058	10/2021	D3006238	34G.F.188	10/2021	D3006408
34G.F.060	10/2021	D3007013	34G.F.190	10/2021	D3006409
34G.F.062	10/2021	D3006215	34G.F.192	27/10/2021	D3007382
34G.F.064	10/2021	D3007471	34G.F.194	10/2021	D3006402
34G.F.066	10/2021	D3007015	34G.F.196	10/2021	D3006403
34G.F.068	10/2021	D3007475	34G.F.198	10/2021	D3006966
34G.F.070	10/2021	D3008185	34G.F.200	27/10/2021	D3007383
34G.F.072	10/2021	D3008187	34G.F.202	10/2021	D3006404
34G.F.074	10/2021	D3006226	34G.F.204	10/2021	D3006405
34G.F.076	10/2021	D3006255	34G.F.206	27/10/2021	D3006406
34G.F.078	10/2021	D3006274	34G.F.208	10/2021	D3006410

					
34G.F.210	10/2021	D3006411	34G.F.332	10/2021	D3007566
34G.F.212	27/10/2021	D3007459	34G.F.334	20/10/2021	D3008927
34G.F.214	16/05/2022	D3009162	34G.F.336	13/10/2022	D3006455
34G.F.216	16/05/2022	D3009163	34G.F.338	10/2021	D3007538
34G.F.218	27/10/2021	D3009164	34G.F.340	16/05/2022	D3008625
34G.F.219_01.001	18/10/2022	D3010219	34G.F.342	16/05/2022	D3008624
34G.F.219_01.003	18/10/2022	D3010215	34G.F.344	10/12/2021	D3008628
34G.F.219_01.005	18/10/2022	D3010217	34G.F.345_01.001	18/10/2022	D3009358
34G.F.219_01.007	18/10/2022	D3010369	34G.F.345_01.003	18/10/2022	D3009365
34G.F.220	10/2021	D3006701	34G.F.345_01.005	18/10/2022	D3009366
34G.F.222	05/11/2021	D3006363	34G.F.345_01.007	18/10/2022	D3009367
34G.F.224	10/2021	D3006841	34G.F.345_01.009	18/10/2022	D3009373
34G.F.226	20/10/2021	D3006150	34G.F.345_01.011	18/10/2022	D3009381
34G.F.228	04/02/2022	D3006153	34G.F.345_01.013	18/10/2022	D3009382
34G.F.230	04/11/2021	D3006145	34G.F.345_01.015	18/10/2022	D3009386
34G.F.231_01.001	18/10/2022	D3009518	34G.F.345_01.017	18/10/2022	D3009390
34G.F.232	10/2021	D3006308	34G.F.345_01.019	18/10/2022	D3009439
34G.F.234	13/12/2021	D3007760	34G.F.345_01.021	18/10/2022	D3009456
34G.F.236	05/11/2021	D3006152	34G.F.345_01.023	18/10/2022	D3009457
34G.F.238	20/10/2021	D3009082	34G.F.345_01.025	18/10/2022	D3009438
34G.F.240	10/2021	D3006309	34G.F.345_01.027	18/10/2022	D3009489
34G.F.242	10/2021	D3009180	34G.F.345_01.029	18/10/2022	D3009673
34G.F.244	10/2021	D3006353	34G.F.345_01.031	18/10/2022	D3010447
34G.F.246	10/2021	D3006434	34G.F.345_01.033	18/10/2022	D3009516
34G.F.248	10/2021	D3006436	34G.F.345_01.035	18/10/2022	D3009446
34G.F.250	10/2021	D3009077	34G.F.345_01.037	18/10/2022	D3009407
34G.F.252	02/11/2021	D3006438	34G.F.345_01.039	18/10/2022	D3009443
34G.F.254	03/11/2021	D3006437	34G.F.345_01.041	18/10/2022	D3009715
34G.F.256	28/04/2022	D3006475	34G.F.345_01.043		
34G.F.258	10/2021	D3006461	34G.G.001	10/2021	
34G.F.260	22/11/2021	D3006459	34G.G.002	02/11/2021	D3006613
34G.F.262	03/11/2021	D3006640	34G.G.003	10/2021	D3006980
34G.F.264	20/10/2021	D3006418	34G.G.004	10/2021	D3006424
34G.F.266	27/10/2021	D3006311	34G.G.005	10/2021	D3006256
34G.F.268	10/2021	D3008996	34G.G.005_01.001	18/10/2022	D3009951
34G.F.270	10/2021	D3006664	34G.G.005_01.002		
34G.F.272	20/10/2021	D3006442	34G.G.006	10/2021	D3006303
34G.F.274	11/07/2022	D3009060	34G.G.007	13/10/2022	D3008745
34G.F.276	11/07/2022	D3006444	34G.G.008	10/2021	D3009085
34G.F.278	14/12/2021	D3006330	34G.G.009	10/2021	D3006604
34G.F.280	10/2021	D3006619	34G.G.010	19/04/2022	D3006355
34G.F.282	10/05/2022	D3009004	34G.G.011	10/2021	D3006305
34G.F.284	10/2021	D3006338	34G.G.012	10/2021	D3006339
34G.F.286	10/2021	D3009147	34G.G.013	10/2021	D3006653
34G.F.288	08/04/2022	D3007758	34G.G.014	27/10/2021	D3006295
34G.F.290	10/2021	D3007761	34G.G.015	10/2021	D3006275
34G.F.292	10/2021	D3008375	34G.G.016	10/2021	D3006347
34G.F.294	07/06/2022	D3006432	34G.G.017	10/2021	D3006976
34G.F.296	07/06/2022	D3009236	34G.G.018	10/2021	D3006395
34G.F.298	08/04/2022	D3008897	34G.G.019	10/2021	D3006396
34G.F.299_01.001	18/10/2022	D3009203	34G.G.020	10/2021	D3006397
34G.F.299_01.003	18/10/2022	D3009204	34G.G.021	10/2021	D3006398
34G.F.299_01.005	18/10/2022	D3010564	34G.G.022	10/2021	D3006348
34G.F.299_01.007	18/10/2022	D3010586	34G.G.023	10/2021	D3006292
34G.F.300	10/2021	D3008875	34G.G.024	10/2021	D3006602
34G.F.302	10/2021	D3008849	34G.G.025	10/2021	D3006357
34G.F.304	03/11/2021	D3006293	34G.G.026	10/2021	D3006359
34G.F.306	26/04/2022	D3008903	34G.G.027	10/2021	D3008633
34G.F.308	26/04/2022	D3008928	34G.G.028	10/2021	D3009084
34G.F.310	03/11/2021	D3006302	34G.G.029	10/2021	D3008042
34G.F.312	03/11/2021	D3006299	34G.G.030	24/03/2022	D3006351
34G.F.314	26/04/2022	D3006533	34G.G.031	10/2021	D3006239
34G.F.316	26/04/2022	D3007352	34G.G.032	07/06/2022	D3007574
34G.F.318	26/04/2022	D3007355	34G.G.033	07/06/2022	D3007351
34G.F.320	10/2021	D3007362	34G.G.034	10/2021	D3006291
34G.F.322	10/2021	D3007387	34G.G.035	10/2021	D3006342
34G.F.324	26/04/2022	D3007363	34G.G.036	10/2021	D3006343
34G.F.326	26/04/2022	D3007388	34G.G.037	10/2021	D3006345
34G.F.328	26/04/2022	D3007833	34G.G.038	10/2021	D3006978
34G.F.330	10/2021	D3007356	34G.G.039	20/10/2021	D3006346

					
34G.G.040	10/2021	D3006376			
34G.G.041	10/2021	D3006377			
34G.G.042	10/2021	D3006378			
34G.G.043	10/2021	D3006379			
34G.G.044	10/2021	D3006380			
34G.G.045	10/2021	D3006381			
34G.G.046	10/2021	D3006382			
34G.G.047	10/2021	D3006383			
34G.G.048	10/2021	D3006384			
34G.G.049	10/2021	D3006385			
34G.G.050	10/2021	D3006655			
34G.G.050_01.001	18/10/2022	D3009311			
34G.G.051	10/2021	D3007543			
34G.G.052	10/2021	D3007544			
34G.G.053	10/2021	D3006654			
34G.G.054	10/2021	D3006632			
34G.G.055	10/2021	D3006633			
34G.G.056	14/06/2022	D3006634			
34G.G.057	10/2021	D3006635			
34G.G.058	10/2021	D3008765			
34G.G.058_01.001	18/10/2022	D3009816			
34G.G.058_01.002	18/10/2022	D3009817			
34G.G.058_01.003	18/10/2022	D3009818			
34G.G.058_01.004	18/10/2022	D3009819			
34G.G.058_01.005	18/10/2022	D3009820			
34G.G.058_01.006	18/10/2022	D3009821			
34G.G.058_01.007	18/10/2022	D3009822			
34G.G.058_01.008	18/10/2022	D3009823			
34G.G.058_01.009	18/10/2022	D3009824			
34G.G.058_01.010	18/10/2022	D3010042			
34G.G.058_01.011					
34G.001	10/2021				
34G.004	10/2021				
34G.007	10/2021				
34G.010	10/2021				

---

# A

---



































Reynaers  
Aluminium































**Algemene informatie**





**Généralités**

























**General Information**

**Allgemeine Information**

	Profiel Profilé Profile Profil	Perfil Profil Profili		Verstek Onglet Mitre Gehrung	Inglete Połączenie katowe Taglio
	Anodisatie- of lakoppervlakte Surface anodisée ou laquée Anodizing or coating surface Eloxierte oder lackierte Oberfläche	Superficie anodizada o lacada Powierzchnia anodowana lub malowana Superficie anodizzata o verniciata		Aantal Nombre Number Anzahl	Número Ilosc Numero
	Polijstoppervlakte Surface à polir Polishing surface Polieroberfläche	Superficie pulida Powierzchnia polerowana Superficie lucidata		Zie pagina Voir page See page Siehe Seite	Ver página Patrz strona Vedi pagina
	Lengte Longueur Length Länge	Longitud Długość Lunghezza		Type toebehoren Type accessoires Type accessories Typ Zubehör	Tipos de accesorios Rodzaj okuc Tipo di accessorio
	Afmetingen Dimensions Dimensions Abmessungen	Dimensiones Wymiary Dimensioni		Glasmaten Dimensions vitres Glass sizes Glasmasse	Dimensiones de los vidrios Wymiary szyby Dimensioni del vetro
	Toepassing Application Application Anwendung	Aplicación Zastosowanie Utilizzo		Toepassing Application Utilization Anwendung	Aplicación Zastosowanie Riferimenti
	Bevestigingsmiddelen Moyens de fixation Fixations Befestigungsmittel	Fijación Mocowanie Fissaggio		Asymmetrisch profiel Profilé asymétrique Asymmetrical profile Asymmetrisches Profil	Perfil asimétrico Profil niesymetryczny Profilo asimmetrico
	Schroeven niet meegeleverd Fourniture sans vis Delivered without screws Lieferung ohne Schrauben	Entregado sin tornillos Dostarczane bez wkrętów Consegnato senza viti		Pagina Page Page Seite	Página Strona Pagina
	Montagevolgorde Ordre de montage The order of assembly Montagereihenfolge	Orden de montaje Kolejność montażu Ordine di montaggio		Laatste editie Dernière édition Last edition Letzte Edition	Edición Poprzednie wydanie Ultima edizione
	Dichtingsmiddel Matière d'étanchéité Sealing agent Abdichtungsmittel	Agente sellante Masa uszczelniająca Siliconatura		Vorige blz Page précédente Previous page Vorige Seite	Página siguiente Poprzednia strona Pagina precedente
	Verlijmen Coller Glue Verkleben	Collado Klej Colla		Verstevigingsprofiel Profil de renforcement Reinforcement profile Verstaerkungsprofil	Perfil refuerzo Profil wzmocniający Profilo di rinforzo
	Vulcaniseerlijm Colle vulcanisante Vulcanizing glue Vulkanisierkleber	Vulcanizante Klej wulkanizacyjny Colla vulcanizzante		Links van buiten gezien Gauche vue extérieur Left seen from outside Links Aussenansicht	Vista izquierda desde el exterior Na lewo widok od zewnątrz Sinistro visto da fuori
	Referentiemaat Dimension de référence Reference dimension Referenzmass	Dimension de referencia Punkt odniesienia wymiarowania Dimensioni di riferimento		Rechts van buiten gezien Droite vue extérieur Right seen from outside Rechts Aussenansicht	Vista derecha desde el exterior Na prawa widok od zewnątrz Destro visto da fuori
	Merkteken Marquage Mark Merkzeichen	Indicación Znak Contrassegno		Reynaprotector Reynaprotector Reynaprotector Reynaprotector	Reynaprotector Reynaprotector Reynaprotector
	Struktureel gelijmd glaswerk Vitrage extérieur collé Structural sealing glazing UV-beständiger Scheibenrandverbund	Sellado acristalado estructural Szyba klejona spoiwem konstrukcyjnym Siliconatura vetro strutturale		Siliconen met lage modulus, compatibel met structurele verlijming Silicon a bas module, compatible avec le collage structurel Low modulus silicone, compatible with structural bonding	Silicona de bajo módulo, compatible con pegado estructural Silikon o niskim module sprężystości, kompatybilny z silikonem strukturalnym Silicone a basso modulo elastico, compatibile con incollaggio strutturale
	Primaire zichtzijde van een profiel Côté visible primaire d'un profilé Primary visible side of a profile Primäre sichtbare Seite eines Profils Secundaire zichtzijde van een profiel Côté visible secondaire d'un profilé Secondary visible side of a profile Sekund. sichtbare Seite eines Profils	Cara vista principal del perfil Główna widoczna powierzchnia profilu Primo lato visibile di un profilo Cara vista secundaria del perfil Drugorzędna widoczna powierzchnia profilu Secondo lato visibile di un profilo		Kleur buitenschaal (e) eerst aangeven in geval van bicolor (.69) En cas de bicolor (.69) il faut indiquer d'abord la couleur du profilé extérieur (e) For bicolor profiles (.69) first of all one should indicate the colour of the outer profile (e) Falls zweifarbig (.69) soll man erst die Farbe des Aussenprofils (e) angeben En cas de bicolor (.69) il faut indiquer d'abord la couleur du angeb	





























	Inbraakwerend Anti-vol Burglar proof Einbruchhemmend	Protección anti- robo Antywłamaniowe Antiscasso		Pershoekverbinding Equerre à sertir Crimp corner cleat Presseckverbinder	Escuadra de ensamblar Naroznik zaciskany Squadrette a cianfrinare
	Basisveiligheid Sécurité de base Basic safety Basissicherheit	Seguridad básica Antywłamaniowosc podstawowa Antiscasso base		Hoekverbinding met schroefhoek (* ) enkel voor klembaar beslag Equerre à blocage (* ) seulement pour accessoires encastrables Corner cleat with screw (* ) only for clamping accessories Eckverbinder mit Spannschraube (* ) nur für klemmbaren Beschlag	Escuadra de atornillar (* ) solo para accesorios apretables Naroznik skrecany (* ) tylko dla akcesoriow zatrzaskiwanych Squadrette ad avvitare (* ) solo per accessori a scatto
	Testen uitgevoerd volgens norm DIN V ENV 1627 Essais effectués par conformément la norme DIN V ENV 1627 Tests carried out according to standard DIN V ENV 1627 Einbruchhemmende Prüfungen gemäß Norm DIN V ENV 1627	Ensayos realizados según norma DIN V ENV 1627 Badania wykonane według normy DIN V ENV 1627 Antiscasso secondo DIN V ENV 1627		T-verbinding met schroef Jonction-T avec vis T-bracket with screw T-Verbinder mit Schraube	Tope de union con tornillo Lacznik teowy skrecany Giunti con viti
	Testen uitgevoerd volgens norm NEN 5096 + ENV 1627 Essais effectués par conformément la norme NEN 5096 + ENV 1627 Tests carried out according to standard NEN 5096 + ENV 1627 Einbruchhemmende Prüfungen gemäß Norm NEN5096 + ENV1627	Ensayos realizados según norma NEN 5096 + ENV 1627 Badania wykonane norm NEN 5098 + ENV 1627 Antiscasso secondo NEN 5098 + ENV 1627		T-verbinding met schroef voor buitendraaiend raam Jonction-T avec vis pour fenêtre ouvrant vers l'ext. T-bracket with screw outside opening window T-Verbinder mit Schraube aussen öffnendes Fenster	Tope Unión con tornillo apertura exterior Lacznik teowy skrecany do okien otwieranych na zewnątrz Cavallotti conuiti ap est.
	Testen uitgevoerd door instituut IBS (Oostenrijk) volgens norm Ö B 3800/3850 Essais effectués par IBS(Autriche) conformément la norme Ö B 3800/3850 Tests carried out by IBS (Austria) according to standard Ö B 3800/3850 Brandschutzprüfungen durchgeführt beim IBS (Österreich) gemäß Norm Ö B 3800/3850	Ensayos hechos por IBS (Austria) según la estandard Ö B 3800/3850 Badania wykonane przez IBS (Austria) według norm Ö B 3800/3850 Testato presso IBS (Austria) IBS secondo Ö B 3800/3850		Vulhoek Equerre de remplissage Corner support Fülleckwinkel	Escuadra de relleno Wspornik narozny Squadretta di riempimento
	Testen uitgevoerd door instituut TNO (Nederland) volgens norm NEN 6069:1997 Essais effectués par TNO (Hollande) conformément la norme NEN 6069:1997 Tests carried out by TNO (The Netherlands) according to standard NEN 6069/1997 Brandschutzprüfungen durchgeführt beim IBS (Österreich) gemäß Norm Ö B 3800/3850	Ensayos realizados fuera por TNO (Holanda) según norma NEN 6069/1977 Badania wykonane przez TNO (Holandia) według norm NEN 6069/1977 Testato presso TNO (Paesi Bassi) secondo NEN 6069/1977		Verstelbare schroefhoek Equerre à visser réglable Adjustable screw corner cleat Verstellbarer Schraubeckwinkel	Escuadra de atornillar regulable Katowy naroznik skrecany Squadrette ad avvitare regolabili
	Brandwerend Anti-feu Fire-proof Feuerhemmend	Resistente al fuego Ognioodporne Anti fuoco		Steunhoeken verstelbaar Cales de feuillure réglables Rebate supports adjustable Verstellbare Eckwinkel Glasanschlag	Escuadra de alineamiento regulable Katowy naroznik nastawny Squadretta di allineamento regolabile
	Testen uitgevoerd volgens norm EN 1634-1(deuren) en EN 1364-1 (beglaasde wanden) Essais effectués par conformément la norme EN 1634-1(portes) et EN 1364-1(parois vitrés) Tests carried out according to standard EN 1634-1(doors) EN 1364-1(glazed partitioning) Prüfungen gemäß Norm EN 1634-1(Türen) und EN 1364-1(verglaste Wände)	Ensayos realizados según norma EN 1634-1 / EN 1364-1 - Badania wykonane według normy 1634-1 / EN 1364-1 - Antifuoco secondo EN 1634-1 / EN 1364-1 -		Hoekverbinding met nagel Equerre avec cheville Corner cleat with drive pin Eckverbinder mit Stift	Escuadra con clavia Lacznik narozny sworzniowy Squadretta a spinare
	Testen uitgevoerd volgens norm EN 1634-1(deuren) en EN 1364-1 (beglaasde wanden) Essais effectués par conformément la norme EN 1634-1(portes) et EN 1364-1(parois vitrés) Tests carried out according to standard EN 1634-1(doors) EN 1364-1(glazed partitioning) Prüfungen gemäß Norm EN 1634-1(Türen) und EN 1364-1(verglaste Wände)	Ensayos realizados según norma EN 1634-1 / EN 1364-1 - Badania wykonane według normy 1634-1 / EN 1364-1 - Antifuoco secondo EN 1634-1 / EN 1364-1 -		T-verbinding met nagel Jonction-T avec cheville T-bracket with drive pin T-Verbinder mit Stift	Tope de union con clavia Lacznik teowy sworzniowy Cavallotto a spinare
	Toebehoren brandwerend Accessoires anti-feu Fire-proof accessories Feuerhemmender Zubehör	Accesorios resistente al fuego Akcesoria ognioodporne Accessori Anti fuoco		T-verbinding met nagel voor buitendraaiend raam Jonction-T avec cheville pour fenêtre ouvrant vers l'ext. T-bracket with drive pin outward opening window T-Verbinder mit Stift nach aussen öffnendes Fenster	Tope unión con clavia apertura exterior Lacznik teowy sworzniowy do okien otwieranych na zewnątrz Cavallotto a spinare ap. est.
	Brandcurve voor buitentoepassingen Courbe de feu complète External fire curve Externe Brandkurve			Verstelbare T-verbinding Jonction-T réglable Adjustable T-bracket Verstellbarer T-Verbinder	Union T regulable Lacznik teowy nastawny Giunti a T regolabili
	Volledige brandcurve voor binnentoepassingen Courbe de feu interne (complète) (Full) Internal fire curve (Volle) Interne Brandkurve			Kruisverbindingen Jonctions transversales Cross connections Kreuzverbindungen	Uniones transversales Polaczenie krzyzowe Collegamento a croce
	Gelaagd glas Verre feuilleté Laminated glass Verbundglas	Vidrio Laminado Szyba laminowana Vetro laminato		Kruisverbinding met schroef Jonction transversale avec vis Cross connection with screw Kreuzverbindung mit Schraube	Union transversal con tornillo Polaczenie krzyzowe skrecane Collegamento a croce con viti
	Glas Verre Glass Glas	Vidrio Szyba Vetro		Bevestiging drager Fixation chevon Fixation rafter Befestigung Dachsparren	Fijacion mainel Mocowanie krokwi Fissaggio montante
	Handleiding Manuel Manual Gebrauchsanweisung	Manual Instrukcja Manuale		Alleen voor CS 77 Seulement pour CS 77 Only for CS 77 Nur für CS 77	Solo para CS 77 Tylo do CS 77 Solo per CS 77

	Alleen voor CS 59 Seulement pour CS 59 Only for CS 59 Nur für CS 59	Solo para CS 59 Tylko do CS 59 Solo per CS 59		Elektrische deuropener Gâche pour serrure électrique Electric door opener Elektrischer Türöffner	Portero automatico Elektryrgiel Apertura porta elettrica
	Alleen voor CS 68 Seulement pour CS 68 Only for CS 68 Nur für CS 68	Solo para CS 68 Tylko do CS 68 Solo per CS 68		Deurgrendels en kantschuiven Verrous de condamnation portes Flush and door bolts Kantriegel und Türriegel	Pasadores puerta Rygle biernych skrzydeł drzwiowych Catenacciolo chiusura centrale
	Eénpuntsluiting Fermeture à 1 point 1-Point lock Einfachverriegelung	Cerradura de 1 punto Zamek 1-punktowy Serratura a 1 punto di chiusura		Geen elektrische spanning bij gesloten deur En cas de porte fermé pas des tension électrique No electric tension in case of closed door Keine elektrische Spannung bei geschlossenen Tür	<b>Sin tensión eléctrica en caso de que la puerta esté cerrada</b> Brak elektrycznego napiecia w przypadku zamkniętych drzwi Stacco tensione a porta chiusa
	Eénpuntsluiting met dagschieter Fermeture à 1 point à pêne 1-Point lock with latch Einfachverriegelung mit Falle	Cerradura 1 punto golpe Zamek 1-punktowy Serratura a 1 punto di chiusura con scrocco		Keine elektrische Spannung bei geschlossenen Tür	
	Eénpuntsluiting met rol Fermeture à 1 points à rouleau 1-Point lock with roller Einfachverriegelung mit Rolle	Cerradura de 1 punto con rodillo Zamek 1-punktowy z barylka Serratura a 1 punto di chiusura con rullino		Raampompen Crémones Window handles Handhebel	Cremona Klamka okienna Cremonese
	Haakslot Serrure à crochet Hook lock Hakenschluss	Cerradura gancho Zamek hakowy Serratura a gancio		Deurkrukken Béquilles Door handles Türdrücker	Manubrios Klamka drzwiowa Maniglie
	Tweepuntsluiting Fermeture à 2 points 2-Point lock Zweifachverriegelung	Cerradura de 2 puntos Zamek 2-punktowy Serratura a 2 punti di chiusura		Sluittingen dubbele deur Serrures pour porte double Locks for double door Türtreibriegel	Cerradura puerta doble Blokada drzwi dwuskrzydłowych Serratura porta a 2 ante
	Driepuntsluiting Fermeture à 3 points 3-Point lock Dreifachverriegelung	Cerradura de 3 puntos Zamek 3-punktowy Serratura a 3 punti di chiusura		Raampomp naar buiten draaiend raam Crémone fenêtre ouvrant vers l'extérieur Handle outward opening window Handhebel nach aussen öffnendes Fenster	Cremona ventana apertura exterior Klamka okna otwieranego na zewnątrz Cremonese apertura est.
	Driepuntsluiting met rol Fermeture à 3 points à rouleau 3-Point lock with roller Dreifachverriegelung mit Rolle	Cerradura de 3 puntos con rodillo Zamek 3-punktowy z barylka Serratura a 3 punti di chiusura con rullino		Raamscharnieren Paumelles pour fenêtres Window hinges Fensterbänder	Bisagras ventana Zawias okienny Cerniere
	Vierpuntsluiting Fermeture à 4 points 4-Point lock Vierfachverriegelung	Cerradura de 4 puntos Zamek 4-punktowy Serratura a 4 punti di chiusura		Deurscharnieren 2-delig Paumelles porte 2-partite Door hinges 2-part Türbänder 2-teilig	Pernio puerta 2 palas Zawias drzwiowy 2-czesciowy Cerniera 2 ali
	Vijfpuntsluiting Fermeture à 5 points 5-Point lock Fünffachverriegelung	Cerradura de 5 puntos Zamek 5-punktowy Serratura a 5 punti di chiusura		Deurscharnieren 3-delig Paumelles porte 3-partite Door hinges 3-part Türbänder 3-teilig	Pernio puerta 3 palas Zawias drzwiowy 3-czesciowy Cerniera 3 ali
	Vijfpuntsluiting met rol Fermeture à 5 points à rouleau 5-Point lock with roller Fünffachverriegelung mit Rolle	Cerradura de 5 puntos con rodillo Zamek 5-punktowy z barylka Serratura a 5 punti di chiusura con rullino		Afstandsbusen Pièces de distance Set of distance bushes Distanzbuchsen	Piezas distanciadoras Tuleje dystansowe Set distanziali
	Zespuuntsluiting Fermeture à 6 points 6-Point lock Sechsfachverriegelung	Cerradura de 6 puntos Zamek 6-punktowy Serratura a 6 punti di chiusura		Geen afstandsbusen nodig Pas de pièces de distance No distance bushes needed Keine Distanzbuchse	No necesario piezas distanciadoras Brak koniecznosci stosowania tuleji dystansowych Senza distanziali
	Zevenpuntsluiting Fermeture à 7 points 7-Point lock Siebenfachverriegelung	Cerradura de 7 puntos Zamek 7-punktowy Serratura a 7 punti di chiusura		Inbraakwerende kogel Bille anti-vol Anti-burglar ball Einbruchhemmende Kugel	Bola proteccion antirobbo Kulka antywłamaniowa Antiscasso
	Espagnoletslot Fermeture espagnolette Espagnolette Lock Treibriegelverschluss	Cierre ventana Zamek drzwiowy do blokady pionowej Serratura a spagnoletta		Dieveklauw Pene anti-degondage Anti-lift pin Sicherheitsbolzen	Perno antielevador Bolec antywyzazeniowy Antisollevamento
	Cilinders Cylindres Cylinders Zylinder	Bombines Cylindry Cilindri		Escudos bombin Osłona wkładki bebenkowej Copertura cilindri	
	Slotpaden Gâches Receivers Schliessbleche	Gancho Gniazdo rygla zamka Riscontri		Kozjindorpelveer Pivot de frein aerien Overhead closer Obentürschliesser	Muelle aereo Samozamykacz gorny Chiudi porta sup.
	Deursluiters Ferre-porte Door closer Türschliesser	Cierrapuertas Samozamykacz drzwiowy Chjidiporta		Vloerveer Pivot de frein au sol Floor closer Bodentürschliesser	Muelle pavimento puerta Samozamykacz podlogowy Chiudi porta inf.

	Eindstuk deurvleugel Pièce finale ouvr. porte End piece door vent Endkappe Türflügel	Tapeta hoja puerta Koncowka do skrzydła drzwiowego Terminale anta		Binnenbeglazingsdichtung Joint à bourrer Inner glazing gasket Innenverglasungsdichtung	Junta de acristalado interior Uszczelka przyszybowa wewnętrzna Guarnizione del vetro interna
	Eindstukken bodemprofiel Pièces finales profilé de seuil End pieces floor profile Endkappe Schwelle	Piezas terminales perfil suelo Koncowki profilu podlogowego Terminale soglia		Buitenbeglazingsdichtung Joint de vitrage extérieur Outer glazing gasket Aussenverglasungsdichtung	Junta de acristalado exterior Uszczelka przyszybowa zewnętrzna Guarnizione del vetro esterna
	Eindstukken Z-T deur Bouchon profilé porte Z-T End pieces Z-T door Endkappe Z-T Tür	Tapetas puerta Z-T Element koncowy Z-T drzwi Terminale profili porte Z e T		Buitenbeglazingsdichtung Joint de vitrage extérieur Outer glazing gasket Aussenverglasungsdichtung	Junta de acristalado exterior Uszczelka przyszybowa zewnętrzna Guarnizione del vetro esterna
	Afdichtingen dorpels Profils latéral pour bavettes Sill end pieces Endstück für Wetterschenkel	Tapetas condensacion Koncowki do profili podokiennych Tappi soglia		Akoestische dichting Joint acoustique Acoustical seal gasket Flügelanschlagdichtung	Junta acustica Uszczelka akustyczna Guarnizione di isolamento acustico
	Glassteunen Supports cale de vitrage Glazing supports Klotzbrücken	Soportes vidrio Podporka pod przeszklenie Supporti per vetro		Middendichtingen Joints centraux Central gaskets Mitteldichtungen	Junta central Uszczelka centralna Guarnizione centrale
	Afdekkap voor waterafvoersleuven Capuchon écoulement d'eau Weep hole cover Abdeckkappe Entwässerung	Deflector aire Maskownica otworu drenazowego Paratempesta		Aanslagdichting Joint de butée Butt strip Anschlagdichtung	Junta tope Uszczelka Guarnizione di battuta
	Eindstukken stolprofielen Bouchons double ouvrant End parts double casement profile Endkappe Stulpprofil	Tapetas perfil doble hoja Koncowka profilu ruchomego slupka Tappo inversione		Dilatatiedichtingen Joints de dilatation Expansion gaskets Dehnungsdichtungen	Junta de dilatacion Uszczelka dylacyjna Guarnizione di espansione
	Koppelstuk Pièce de raccordement Connection piece Kopplungsstueck	Pieza de union Element łączący Accessori collegamento		Dichting Joint Gasket Dichtung	Junta Uszczelka Guarnizione
	Eindstukken voor stolprofielen Bouchons pièce finale pour profilé double ouvrant End parts for double casement profiles Endkappen für Stulpprofile	Tapeta perfil doble hoja Koncowka profilu ruchomego slupka Tappi 2 ante		Dichting Joint Gasket Dichtung	Junta Uszczelka Guarnizione
	Afdichting goot Fermeture gouttière End piece gutter Endkappe Rinne	Tapetas canal Koncowka rynny Terminale gronda		Afdichtingsstuk Pièce d'étanchéité Sealing piece Dichtstück	Pieza de sellado Element uszczelniający Accessorio per sigillatura
	Afdichting goot Fermeture gouttière End piece gutter Endkappe Rinne	Tapetas canal Koncowka rynny Terminale gronda		Opzwellende Dichting Joint Gonflant Swelling Gasket Schwellende Dichtung	Junta veranda Uszczelka do werandy Guarnizione espansione
	Eindstuk Pièce finale End piece Endkappe	Terminal Koncowka Terminale		Dichting veranda Joint veranda Gasket veranda Dichtung Wintergarten	Junta veranda Uszczelka do werandy Guarnizione veranda
	Stootplaat Arrêt vitrage toiture Glass panel stop Endstück Verglasung	Tope del panel de vidrio Ogranicznik wypełnienia Ferro x vetro		Borsteldichtingen Joints brosse Brushes Bürstendichtungen	Cepillos Szczotki Spazzole
	Veranda type 1 Veranda type 1 Veranda type 1 Veranda Typ 1	Veranda tipo 1 Weranda typu 1 Veranda tipo 1		Isolerend vulstuk Pièce de remplissage isolante Insulating filling piece Isolierendes Füllstück	Pieza de relleno aislante Wkładka izolacyjna Riempimento isolanta
	Paniekdeur Porte de panique Panic door Paniktür	Puerta antipánico Drzwi antypaniczne Porta antipanico		Einddichting Joint d'assemblage End gasket Enddichtung	Junta Uszczelka koncowa Angolo prestampato
	Diversen Divers Miscellaneous Diverse	Diversos Elementy uzupełniające Varie		Isolatie Isolant Insulation Isolation	Aislamiento Izolacyjna Isolante
	Klemstuk Clip Clip Federklemme	Clip Uchwyt Clip		Briefenkleppen Entrées de courrier Letter boxes Briefeinwurf	Buzones Skrzynka na listy Cassetta posta
	Nokbevestiging Fixation de la faitière Fixation of the ridge Firstanschluss	Fijacion del resalte Element mocujący kalenicowy Fissaggio colmo		Automatische deurdichtingen Fermetures automatiques Automatic door latches Automatische Türdichtungen	Cierrapuertas automaticos Drzwiowa automat. opadajaca listwa Dispositivo di chiusura soglia
				Variant Variante Variant Variante	Variante Wariant Variante

	Stalp-kipraam Fenêtre double ouvr.-batt. Double casem.-tilt window Stulpfenster D/DK	Ventana abatible doble hoja Okno rozwierano-uchylne dwuskrzydlowe Finestra a 2 ante ribalta		DRAAISCHUIFFRAAM OUVRANT PROJETANT SIDE-HUNG SLIDING WINDOW DREHSCHIEBEFENSTER
	Draaikip Oscillo-battant Turn and tilt Drehkip	Oscilobatiente Okno rozwierno-uchylne Anta ribalta		
	Kipdraai Battantes-ouvrantes Tilt and turn Kippdreh	Batiente oscilante Okno uchylno-rozwierane Anta ribalta inversa		
	Draairaam Fenêtre ouvrante Side-hung window Drehfenster	Ventana practicable Okno rozwierane Battente		
	Stolpraam Fenêtre double ouvrant Double casement window Stulp-Flügel Fenster	Ventana doble hoja Okno rozwierane wuskrzydlowe Finestra a 2 ante		
	Valraam Fenêtre à soufflet Bottom hung window Kipp-Fenster	Ventana abatible Okno uchylne Wasistas		
	Afstandbedieningen valraam Commandes à distance pour fenêtre à soufflet Remote control for fanlight window Oberlichtbeschlag für Kipp-Flügel	Funcionamiento a distancia para ventana de techo Mechanizm do dystansowego uchylania okien Wasistas con telemando		
	Buitendraaiend raam Fenêtre ouvrant vers l'extérieur Outside opening window Nach aussen öffnendes Fenster	Ventana apertura exterior Okno otwierane na zewnatr Finestra ad apertura esterna		Verankeringen Ancrages Fixing lugs Verankerungen
	Uitzetzakraam Châssis à l'italienne Top-hung window Senk-Klappfenster	Ventana proyectante con compas Okno wychylne na zewnatr Sporgere con frizioni		Bulones y cerraderos Plytka i kolek ryglujacy Schliessrollen und Schliessstücke
	Tuimel- en taatsraam Châssis pivotant Pivot window Schwingflügel	Ventana pivotante Okno obrotowe Bilico		Canal Rynna Gronda
	Vouwdeur Porte pliante Folding door Falltür	Puerta plegable Drzwi harmonijkowe Veranda libro		Dakvenster Tabatière Attic window Dachfenster
	Schuifkip (TF) Coulissant-tombant (TF) Slide and tilt (TF) Schiebekipptür (TF)	Paralela Uchylno-przesuwny Scorrevole parallelo		Kunststof dakbedekking Toiture synthétique Synthetic roofing Kunststoff Dachdeckung
	Schuifraam Fenêtre coulissante Sliding window Schiebefenster	Ventana corredera Okno przesuwne Scorrevole		Zelfklevende dubbelzijdige tape Bande autocollante 2 faces Self-adhesive double sided tape Selbstklebendes beidseitiges Band
	Parallel opengaand raam Fenêtre ouvrant parallele Parallel opening window Parallelausstellfenster	Ventana proyectante paralela Okno rovnolegle wysuwane na zewnatr Sporgere parallelo		Domotica Domotique Domotics Domotik
	Kipraam Fenêtre battante Tilt window Kipfenster	Oscilo Okno uchylne Vasidas		Profielen met hoge isolatiewaarde Profils avec valeur d'isolation élevée Profiles with high insulation value Profile mit hohen Isolationswert
	Dubbele deur buitendraaiend Porte double ouvrant vers l'ext. Double door outward opening Zweiflügelige Tür aussen öffnend	Puerta doble apertura exterior Drzwi dwuskrzydlowe otw. na zew. Porta due ante apertura esterna		Wielen Galets Rollers Laufwagen
	Deur binnendraaiend Porte ouvrant vers l'int. Door inward opening Tür nach innen öffnend	Puerta apertura interior Drzwi otw. do wewnatr Porta apertura interna		Regeltringels Tringles de réglage Adjustment rods Regulierstange
	Deur buitendraaiend Porte ouvrant vers l'ext. Door outward opening Tür aussen öffnend	Puerta apertura exterior Drzwi otw. na zewnatr Porta apertura esterna		Geleidingsplaat Guide Guide plate Führung

	Gereedschap Outils Tool Werkzeug	Util Narzędzie Utensile		Hydropneumatische pers Presse hydropneumatique Hydropneumatic press Hydropneumatische Presse	Prensa neumática Prasa hydropneumatyczna Pressa idropneumatica
	Gereedschappen en machines voor ontwatering van kader Outils et machinerie pour drainage dormant Tools and machinery for draining outer frame Werkzeuge und Maschinen für Entwässerung Blendrahmen	Utiles y maquinaria para el drenaje del marco Narzędzia i maszyny do drenazy osiecznic Utensili e macchinari per il drenaggio del telaio		Zaagmachine Tronçonneuse Sawing machine Kreissäge	Maquina de corte Pila do ciec przestrzennych Macchina per taglio
	Gereedschappen en machines voor ontwatering van vleugel Outils et machinerie pour drainage ouvrant Tools and machinery for draining vent Werkzeuge und Maschinen für Entwässerung Flügel	Utiles y maquinaria para el drenaje de la hoja Narzędzia i maszyny do drenazy skrzydeł Utensili e macchinari per il drenaggio dell'anta		Handmatrijs Matrice manuelle Manual punch tool Handstanzwerkzeug	Prensa manual Wykrojnik ręczny Punzonatrice manuale
	Decompressie Decompression Decompression Dekompression	Descompresion Dekompresja Decompressione		Gereedschap voor krukken Outils pour cremones Tool for handles Werkzeug fuer Handhebel	Util para manetas Narzędzie do klamek Utensile per maniglie
	Gereedschappen en machines voor T-verbinding Outils et machinerie pour jonction-T Tools and machinery for T-brackets Werkzeuge und Maschinen für T-Verbinder	Utiles y maquinaria para topes de unión Narzędzia i maszyny do polaczen teowych Utensili e macchinari per i giunti		Gereedschap voor sluitlatten Outils pour tringles Tool for linkbars Werkzeug fuer Schubstange	Util para barras union Narzędzie do listew sterujacych okuciami Utensile per barre di collegamento
	Gereedschap voor T-verbindingen Outils pour connections-T Tool for T-connections Werkzeug fuer T-Verbindungen	Util para topes de union Narzędzie do polaczen Teowych Utensile per travesi		Gereedschap voor krukken Outils pour cremones Tool for handles Werkzeug fuer Handhebel	Util para manetas Narzędzie do klamek Utensile per maniglie
	Gereedschappen en machines voor krukuitsparing Outils et machinerie pour fermeture Tools and machinery for closure Werkzeuge und Maschinen für Beschläge	Utiles y maquinaria para el cierre Narzędzia i maszyny do zamkniec Utensili e macchinari per le chiusure		Klemblokken Blocs de serrage Clamping blocks Spannbacken	Bloques de presión Blokli zaciskowe Blocchetti di supporto
	Multifunctionele matrijs Matrice multifonctionnelle Multifunctional punch tool Mehrzweckstanzwerkzeug	Matriz multifuncional Wykrojnik wielofunkcyjny Punzonatrice multifunzionale		Gereedschap voor ontwatering buitenkaders Outils pour drainage dormants Tool for drainage outer frames Werkzeug fuer Entwässerung Blendrahmen	Util drenaje marco Narzędzie do drenazy osiecznic Utensile per drenaggio telaio
	Geleide matrijs Matrice guidée Punch tool Stanzwerkzeug	Matriz Wykrojnik Punzonatrice		Gereedschap voor hoekverbinding Outils pour connection d'equerre Tool for corner connection Werkzeug fuer Eckverbinding	Util union esquina Narzędzie do polaczen narozynych Utensile per connessioni d'angolo
	Geleide matrijs Matrice guidée Punch tool Stanzwerkzeug	Matriz Wykrojnik Punzonatrice		Gereedschap voor montage Outils pour montage Tool for assembly Werkzeug für Montage	Util para colocacion Narzędzie do montazu Utensile assemblaggio
	Handmatig gereedschap Outils manuel Manual tools Handwerkzeuge	Util manual Narzędzie ręczne Dime		Gereedschap voor deursluiser Outils pour fermeture porte Tool for door closer Werkzeug für Türschliesser	Util para cierrapuertas Narzędzie do samozamykacza drzwiowego Utensile chiu di porta
	Freessjabloon Calibre de fraisage Stencil plate for milling head Fräseschablone	Plantilla para copiadora Szablon do frezarki Maschera per pantografo		Gereedschap voor scharnieren Outils pour charnières Tool for hinges Werkzeug für Bänder	Util para bisagras Narzędzie do zawiasy Utensile cerniere
	Enkelkopse freesmachine Frais. à copier à une broche Copy router 1 spindle Einspindel-Kopierfräse	Copiadora de un cabezal Frezarka z jedna glowica Pantografo di copia a 1 mandrino 1 mandrino		Gereedschap voor sloten Outils pour fermetures Tool for locks Werkzeug für Schlösser	Util para cerraduras Narzędzie do zamka Utensile serrature
	Freess- en boormachine Fraiseuse et foreuse Router and drilling machine Fräse- und Bohrgerät	Copiadora taladradora Frezarka z wiertarka Centro dilavoro		Gereedschap voor wisselprofielen Outils pour chicanes Tool for sections Werkzeug für Wechselprofile	Util para encuentros centrales Narzędzie do przekrojow Utensile chicanes
	Bewerkingscentrum Centre d'usinage Machining center Bearbeitungszentrum	Centre de mecanizado Centrum obroczce Centro di lavoro		Gereedschap voor beglazing Outils pour vitrage Tool for glazing Werkzeug für Verglasung	Util para acristalamiento Narzędzie do przeszklen Utensile vetro
	Gereedschap voor diverse toepassingen Outils pour applications divers Tool for miscellaneous applications Werkzeug für diverse Anwendungen	Utiles para varias aplicaciones Narzędzie do montazu elementow uzupelniających Utensile vari		Gereedschap voor diverse toepassingen Outils pour applications divers Tool for miscellaneous applications Werkzeug für diverse Anwendungen	Utiles para varias aplicaciones Narzędzie do montazu elementow uzupelniających Utensile vari

	Gereedschap voor dichtingen Outillage pour joints Tool for gaskets Werkzeug für Dichtungen	Util para juntas Narzędzie do uszczelki Utensile guarnizioni		Pneumatische aandrijving Propulsion pneumatic Pneumatic drive Pneumatische Antrieb	Destornillador neumático Pneumatyczny napęd Cilindro pneumatica
	Gereedschap voor bevestiging wielen Outillage pour fixation des roulettes Tool for fixation rollers Werkzeug für Befestigung Laufräder	Util para fijación de ruletas Narzędzie do montażu wózków Utensile carrelli		Ponsunit Unité d'étamper Punch unit Stanzeinheit	Punzon Wykrojnik Unità punzonatrice
	Gereedschap voor ontwatering vleugels Outillage pour drainage ouvrants Tool for drainage vents Werkzeug für Entwässerung Flügel	Util para drenaje hoja Narzędzie do drenażu skrzydła Utensile drenaggio anta		Land Pays Country Land	Pais Kraj Nazione
	Gereedschap voor ontwatering vleugels Outillage pour drainage ouvrants Tool for drainage vents Werkzeug für Entwässerung Flügel	Util para drenaje hoja Narzędzie do drenażu skrzydła Utensile drenaggio anta		Min. profiellengte Longueur min. de profilé Min. length of profile Min. Profillänge	Longitud mínima del perfil Minimalna długość profilu Lunghezza minima profilo
	Uitfrezing voor inbouw bovenspeun in kozijn Fraisage pour encastrement gond supérieur dans la fenêtre Milling for building in upper pivot in window Ausfräsung für Einbau eines oberen Lagers im Rahmen	Fresado para pivotante en marco superior Frez do montażu gornego sworznia w oknie Lavorazioni super. finestra pivotante		Max. profiellengte Longueur max. de profilé Max. length of profile Max. Profillänge	Longitud máxima del perfil Maksymalna długość profilu Lunghezza max profilo
	Uitfrezing voor inbouw vloerspeun in vleugel Fraisage pour encastrement gond inférieur dans l'ouvrant Milling for building in floor pivot in vent Ausfräsung für Einbau eines Bodenlagers im Flügel	Fresado para pivotante en hoja inferior Frez do montażu dolnego sworznia w skrzydle Lavorazioni infer. finestra pivotante		Max. profielhoogte Hauteur max. de profilé Max. height of profiles Max. Profilhöhe	Altura máxima del perfil Maksymalna wysokość profilu Max altezza
	Uitfrezing voor inbouw vloerspeun in vleugel Fraisage pour encastrement gond inférieur dans l'ouvrant Milling for building in floor pivot in vent Ausfräsung für Einbau eines Bodenlagers im Flügel	Fresado para pivotante en hoja inferior Frez do montażu dolnego sworznia w skrzydle Lavorazioni infer. finestra pivotante		Max. horizontale beweging Movement max. horizontale Max. horizontal movement Max. horizontale Versetzung	Movimiento horizontal máximo Maksymalny ruch poziomy Spostamento orizz. max
	Uitfrezing voor inbouw bovenspeun in vleugel Fraisage pour encastrement gond supérieur dans l'ouvrant Milling for building in upper pivot in vent Ausfräsung für Einbau eines oberen Lagers im Flügel	Fresado para pivotante en hoja superior Frez do montażu gornego sworznia w skrzydle Lavorazione super. finestra pivotante		Horizontaal hoekbereik Intervalle d'équerre horizontale Horizontal corner range Eckbereich Horizontal	Rango de corte a inglete horizontal Zakres katów poziomych Dimensione taglio orizz.
	Uitfrezing voor inbouw bovenspeun in vleugel Fraisage pour encastrement gond supérieur dans l'ouvrant Milling for building in upper pivot in vent Ausfräsung für Einbau eines oberen Lagers im Flügel	Fresado para pivotante en hoja superior Frez do montażu gornego sworznia w skrzydle Lavorazione super. finestra pivotante		Verticaal hoekbereik Intervalle d'équerre verticale Vertical corner range Eckbereich Vertikal	Rango de corte a inglete vertical Zakres katów pionowych Dimensione taglio vert.
	Monteertafel Table de montage Assembly bench Montagetisch	Banco de montaje Stół montażowy Banco montaggio		Motor Moteur Motor Antrieb	Motor Silownik napędowy Motore
	Elektrische aansluiting Fixation électrique Electric connection Elektrisches Anschluss	Conexión eléctrica Polaczenie elektryczne Connessione elettrica		Gewicht Poids Weight Gewicht	Pesos Ciezar Peso
	Elektrische aansluiting Fixation électrique Electric connection Elektrisches Anschluss	Conexión eléctrica Polaczenie elektryczne Connessione elettrica		Max. toerental Vitesse d'axe max. Max. spindle speed Max. Drehzahl	Velocidad de sierra Maksymalna predkosć obrotowa Velocità max lama
	Compressor Compresseur Compressor Kompressor	Compresor Kompresor Compressore		Motor Moteur Motor Antrieb	Motor Silownik napędowy Motore
	Kogel Dr. Hahn Bille Dr. Hahn Ball Dr. Hahn Kugel Dr. Hahn	Bola Dr. Hahn Kulka Dr. Hahn -			
	Mechanische aansluiting Fixation mecanique Mechanical connection Mechanischer Anschluss	Conexión mecánica Polaczenie mechaniczne Fissaggio meccanico			

**B**

**R**

Reynaers  
Aluminium

**Algemene informatie systemen**

**Généralités séries**

**General Information System**

**Allgemeine Information System**

# VERWERKINGSVOORSCHRIFTEN

## I. ALGEMEEN

Zie catalogus "1.Algemene informatie" (089.C01\*.\*\*) )

## II. VERWERKINGSVOORSCHRIFTEN MASTERPATIO

### II.1 CONSTRUCTIEVOORSCHRIFTEN

Om blijvend een perfect eindproduct te garanderen, dienen tijdens de verwerking bepaalde regels in acht genomen te worden.

#### II.1.1 Verspanende bewerkingen

Onder verspanende bewerkingen wordt verstaan: alle mechanische bewerkingen zoals zagen, frezen, boren ponsen en knippen. Voor gelakte profielen is het essentieel dat de laklagen aan de randen niet loskomen tijdens deze bewerkingen. Het is daarom van groot belang voor de kwaliteit van de verbindingen dat:

Het verspanende gereedschap geschikt en voldoende scherp is.

De machines goed afgeregeld zijn (bv. Toerental).

Een regelmatige controle van het gereedschap gebeurt.

Het verspanende gereedschap correct en voldoende gesmeerd wordt:

Smeerstick Reynalube (art. Nr. 086.9191.UN) voor zaagbladen.

Snijmiddel (art.nr. 086.9175.UN) voor ponsgereedschap.

Of de door de machineleverancier voorgeschreven koel- en smeermiddelen.

De gepaste klemblokken worden gebruikt. (zie montagetekening "klemblokken")

De aan- en afvoertafel vrij zijn van spanen en verontreinigingen.

Eventuele koeling gebeurt met chemische neutrale producten die de oppervlaktebehandeling niet aantasten.

Voor het correct functioneren, het behalen van de performanties en de esthetiek van het eindproduct is het van groot belang dat de profielen binnen nauwe toleranties verzaagd worden. Indien er onenigheid zou bestaan over wat er onder acceptabele afwijkingen verstaan wordt kan men de richtlijnen van instanties als het Aluminium Center Belgium raadplegen.

#### Positie / klemming van de profielen tijdens het zagen:

De positie van de profielen op de zaagtafel tijdens het verzagen is zeer belangrijk en is de basis om perfecte verstekken te bekomen na montage van schuifelementen.

De grootste druk moet steeds op de „referentiezijde“ van de profielen uitgeoefend worden.

De „referentiezijde“ moet perfect horizontaal of verticaal op de zaagtafel geplaatst worden.

Klemblokken moeten gebruikt worden:

- om te vermijden dat de speling op de profielen de kwaliteit van het verstek zou beïnvloeden.
- om te vermijden dat de profielen zouden kantelen op de tafel.

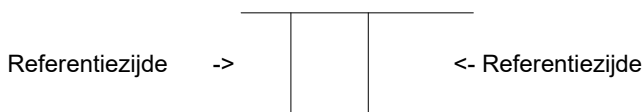

#### FOUTIEVE KLEMMING

FOUT: De hoofdklemming drukt op de zichtkant van het te verzagen profiel en het profiel kantelt.

GEVOLG: Scheven zaagsnede – de buitenzijde is korter dan de binnenzijde.

RESULTAAT: Bij het persen van de hoeken is het verstek aan de binnenzijde keurig dicht en gaapt aan de buitenzijde.

#### JUISTE KLEMMING

De hoofdklemming drukt op de sponningzijde. De zichtkant ondergaat een kleinere, secundaire druk.

Het profiel heeft niet de neiging te kantelen of te vervormen tijdens het zagen, en het persen van de in verstek gezaagde profielen kan probleemloos verlopen.

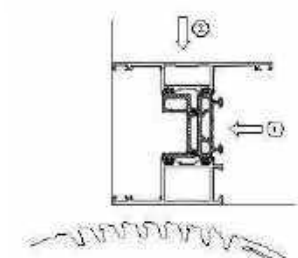
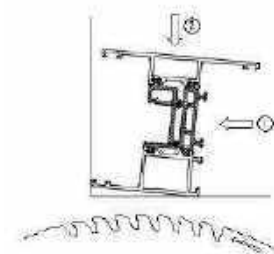

**Opmerking:**

Het verdient aanbeveling om spanen die ontstaan tijdens het zagen af te zuigen.

Alle zaagsnedes die een verbinding vormen zoals: hoek- en T-verbindingen, dienen beschermd te worden met reynaprotector. Andere zaagsnedes zoals: glaslatten, klemlijsten,... dienen beschermd te worden met Reynaers Anti-Corro (art.nr. 086.9606.--), alsook freessnedes, boorgaten, pongaten,...

**II.1.2 Assemblage**

Wij maken de volgende onderverdeling:

1. hoekverbindingen;  
    Persen  
    Schroeven  
    Vernagelen
2. T-verbindingen en kruisverbinding;
3. ontwatering en uitsparingen voor het beslag;
4. Dichtingen.

**II.1.2.1 Hoekverbindingen**

Voordat de hoekverbindingen tot stand worden gebracht dient gecontroleerd te worden dat alle verspanende bewerkingen benodigd voor de afwerking van het raam correct zijn uitgevoerd. Sommige van deze bewerkingen zijn achteraf niet meer aan te brengen.

**II.1.2.1.1 Persen**

Stappen:

- a. Correct zagen.
- b. Beschermen van de zaagsnedes en bewerkte vlakken door:  
    -ontbramen (indien noodzakelijk).  
    -verwijderen van stof en zaagresten op de zaagsnede en in de profielkamer.
- c. Ontvetten (Reynafinish 60 art. nr. 086.9210.-- of Reynaers safety clean 086.9231.--);  
    Aanbrengen van Reynaprotector op zaagsnedes en Reynaers Anti-Corro (art.nr. 086.9606.--) op de freessnedes.
- d. Lijm aanbrengen in de profielkamers van een goedgekeurd dichtingslijm (Reynaseal duo art. nr. 084.9080.--).
- e. Aanbrengen pershoeken en vulhoeken.
- f. Verbinding tot stand brengen en persen

De samengevoegde elementen dienen enkel aan de zichtvlakken gereinigd te worden van lijmresten en dit uitsluitend met een niet-agressief middel (Reynafinish 60 art. nr. 086.9210.-- of Reynaers safety clean 086.9231.--);

Opmerkingen:

Om een goede afdichting te voorzien van de buitenkader dient men een extra afdichtingsstuk te voorzien tussen de rechte hoekverbinding.

**II.1.2.1.2 Schroeven**

Stappen

- a. Correct zagen.
- b. Aanbrengen van pengaten.
- c. Beschermen van de zaagsnedes en bewerkte vlakken door:  
    -ontbramen (indien noodzakelijk).  
    -verwijderen van stof en zaagresten op de zaagsnede en in de profielkamer.
- d. ontvetten (Reynafinish 60 art. nr. 086.9210.-- of Reynaers safety clean 086.9231.--);
- e. aanbrengen van Reynaprotector op zaagsnedes en Reynaers Anti-Corro (art.nr. 086.9606.--) op de freessnedes.
- f. Lijm aanbrengen in de profielkamers van een goedgekeurd dichtingslijm (Reynaseal duo art. nr. 084.9080.--).
- g. Aanbrengen schroefhoeken en vulhoeken.
- h. Verbinding tot stand brengen en schroeven en vernagelen
- i. De samengevoegde elementen dienen enkel aan de zichtvlakken gereinigd te worden van lijmresten en dit uitsluitend met een niet-agressief middel (Reynafinish 60 art. nr. 086.9210.-- of Reynaers safety clean 086.9231.--);

Opmerkingen:

Om een goede afdichting te voorzien van de buitenkader dient men een extra afdichtingsstuk te voorzien tussen de rechte hoekverbinding.

### II.1.2.1.3 Vernagelen

Stappen:

- a. Correct zagen.
- b. Aanbrengen van pengaten.
- c. Beschermen van de zaagsneden en bewerkte vlakken door:  
ontbramen (indien noodzakelijk).  
verwijderen van stof en zaagresten op de zaagsnede en in de profielkamer.
- d. ontvetten (Reynafinish 60 art. nr. 086.9210.-- of Reynaers safety clean 086.9231.--);
- e. aanbrengen van Reynaprotector op zaagsneden en Reynaers Anti-Corro (art.nr. 086.9606.--) op de freessneden.
- f. Lijm aanbrengen in de profielkamers van een goedgekeurd dichtingslijm (Reynaseal duo art. nr. 084.9080.--).
- g. Aanbrengen schroefhoeken en vulhoeken.
- h. Verbinding tot stand brengen en vernagelen of pennen.
- i. De samengevoegde elementen dienen enkel aan de zichtvlakken gereinigd te worden van lijmresten en dit uitsluitend met een niet-agressief middel (Reynafinish 60 art. nr. 086.9210.-- of Reynaers safety clean 086.9231.--);

Opmerkingen:

Om een goede afdichting te voorzien van de buitenkader dient men een extra afdichtingsstuk te voorzien tussen de rechte hoekverbinding.

### II.1.2.2 T-Verbindingen

Stappen:

- a. Correct zagen T-profiel.
- b. Aanbrengen gaten T-verbinder
- c. Uittraven T-profiel
- d. Bescherming van de zaagsneden en bewerkte vlakken door:  
Ontbramen (indien noodzakelijk);  
Verwijderen van stof en zaagresten op de zaagsnede en in de profielkamer;
- e. Ontvetten (Reynafinish 60 art. nr. 086.9210.-- of Reynaers safety clean 086.9231.--);
- f. Aanbrengen van Reynaprotector op zaagsneden en Reynaers Anti-Corro (art.nr. 086.9606.--) op de freessneden.
- g. Afdichten van T-profiel door aanbrengen van een neutraal, elastisch dichtingmiddel:  
Op de zaagsneden;  
Op de bevestigingsgaten;
- h. Afdichting van zone onder T-profiel op het kaderprofiel, door plaatsen van afdichtingselementen of aanbrengen van een neutraal elastisch dichtingsmiddel. Deze dienen volledig waterdicht uitgevoerd te worden. (monorail)
- i. Verbinding tot stand brengen: De T-verbinder wordt gepositioneerd op centerlijn, T-profiel wordt hierover aangebracht, T-verbinder wordt vastgeschroefd en vernageld (of 2x vernageld).
- j. De samengevoegde elementen dienen enkel aan de zichtvlakken gereinigd te worden van dichtingresten en dit uitsluitend met een niet-agressief middel (Reynafinish 60 art. nr. 086.9210.-- of Reynaers safety clean 086.9231.--);

### II.1.2.3 Ontwatering, ontluchting en uitsparingen voor het beslag

Stappen:

- a. Aftekenen uitsparingen.
- b. Correct ponsen, boren of frezen.
- c. Beschermen van de bewerkte vlakken door:  
Ontbramen (indien noodzakelijk).  
Verwijderen van stof en zaagresten op de zaagsnede en in de profielkamer.
- d. Ontvetten (Reynafinish 60 art. nr. 086.9210.-- of Reynaers safety clean 086.9231.--);
- e. Aanbrengen van Reynaers Anti-Corro

Aandachtspunten bij de ontwatering / ontluchting:

Eventueel binnendringend water moet vlot en gecontroleerd kunnen afgevoerd worden en de druk in de binnenkamers moet gelijk blijven aan die van de buitenlucht.

- Bij elk schuifelement worden er ontwateringopeningen voorzien met een maximale afstand tot de hoek van 250 mm voor de vleugel en 150 mm voor het vast kader. De afstand tussen 2 ontwateringopeningen bedraagt max. 800 mm.

Per raamvak dienen min. 2 ontwateringsopening voorzien te worden!

- Steeds op het laagste punt van de glasspanning afwateren

- Alle types schuifelementen moeten voorzien zijn van een ontwateringsysteem in de onderregels en / of de horizontale T-profielen.

- De minimale oppervlakte van deze ontwateringsopeningen bedraagt 50 mm<sup>2</sup> per opening in de vleugel, hetzij een ronde opening van minimum 8 mm diameter, hetzij langwerpige openingen van minimaal 5 mm bij 15 mm. Voor het vast kader bedraagt de minimale oppervlakte 150 mm<sup>2</sup> per opening hetzij 3 ronde openingen van min. 8 mm diameter, hetzij een langwerpige opening van minimaal 8 mm bij 34 mm.

- Ontwateringsgaten die aan de buitenzijde van het schuifelement zichtbaar zijn, worden afgedekt met kunststofkapjes.
- Bij elk schuifelement worden er ontluchtingsgaten voorzien. De functie hiervan is de drukegalisatie rond de beglazing te waarborgen.
- Aan de zijkant bovenaan van de vleugel wordt steeds minimum 1 ontluchtingsopening van minimum Ø5mm geboord. (zie bladzijde G34.F. ...)
- Bij een vast licht wordt de buitenbeglazingsdichting (180.9114.SY) onderbroken over een afstand van 50 mm.

Opmerking: Voor specifieke ontwateringen verwijzen wij naar bladzijde G34.F. ...

#### **II.1.2.4 Dichtingen**

Alle dichtingrubbers zijn van weer- en verouderingsbestendig EPDM. De verwerking ervan dient zorgvuldig te gebeuren, aangezien hiervan de dichtheid van het schuifelement afhangt.

##### **a. Het aanbrengen van de dichtingen/ beglazingsdichtingen**

Stappen:

1. Correct versnijden: Het versnijden van de beglazingsdichting dient met een speciale schaar (art. nr. 090.0121.UN) te gebeuren. De dichting kan naargelang de soort profielverbinding in verstek of recht versneden worden. Benodigde overlengte (ca 10 mm per meter) dient voorzien te worden.
2. Aanbrengen dichting: de dichtingen worden aangebracht in de daarvoor voorziene groeven van de profielen. De overlengte wordt lichtjes opgestuikt om uitzetten of krimpen op te vangen. Moeilijkheden bij het inbrengen kunnen opgevangen worden met een siliconenspray (art. nr. 086.9551.--).
3. Verlijmen (afdichten): in de hoeken dient de beglazingsdichting verlijmd te worden aan de hoekstukken met vulkaniseerlijm (art. nr. 084.9108.04). Doordat de verbinding elastisch blijft, sluit de dichting ook in de hoeken perfect aan.

##### **b. Het aanbrengen van de borsteldichtingen**

Stappen:

1. Correct versnijden: het versnijden van de borsteldichting dient met een speciale schaar (art. nr. 090.0121.UN) te gebeuren en de dichting kan naargelang van de soort profielverbinding in verstek of recht versneden worden.
2. Aanbrengen borsteldichting: de borsteldichtingen worden geschoven in de daarvoor voorziene groeven van de profielen.
3. Verlijmen: Naargelang de soort profielverbinding (recht) dient de borsteldichting aan de uiteinden verlijmd te worden met secondenlijm (Reynaglue art. nr. 084.9107.--). Deze verlijming is noodzakelijk om het uitglijden van de borsteldichting te vermijden.

##### **c. Het aanbrengen van een afdichting onder- en bovenaan het wisselprofiel**

Om een goede water- en winddichtheid te bekomen dient onder- en bovenaan het wisselprofiel een extra afdichting geplaatst te worden.

## II.1.2.5 Fabricatie toleranties

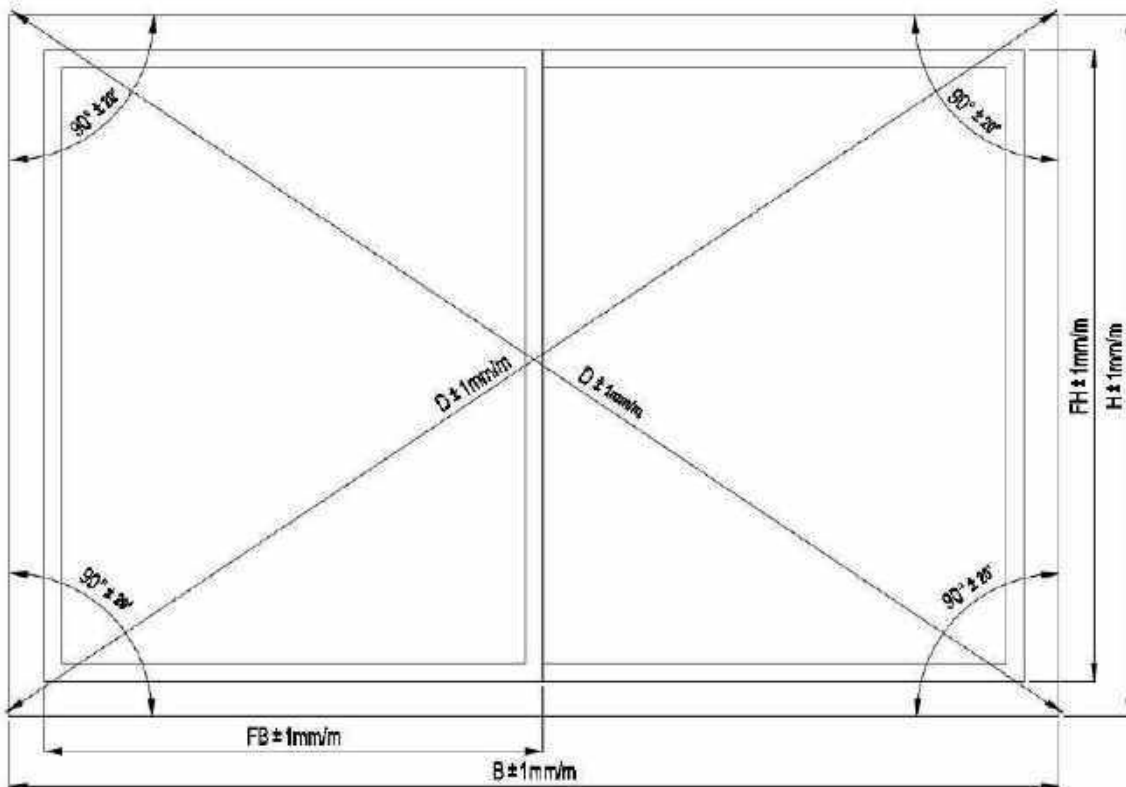

$$- 1\text{mm} < \Delta H - \Delta FH < + 1\text{mm}$$

Monorail XQ:	- 2mm < ( $\Delta FBX + \Delta FBQ$ ) - $\Delta B$ < + 4mm
Monorail XQX:	- 4mm < ( $\Delta FBX1 + \Delta FBQ + \Delta FBX2$ ) - $\Delta B$ < + 8mm
Monorail QXQ:	- 2mm < ( $\Delta FBQ1 + \Delta FBX + \Delta FBQ2$ ) - $\Delta B$ < + 4mm
Monorail QXXQ:	- 4mm < ( $\Delta FBQ1 + \Delta FBX1 + \Delta FBX2 + \Delta FBQ2$ ) - $\Delta B$ < + 6mm
2-rail XQ:	- 2mm < ( $\Delta FBX + \Delta FBQ$ ) - $\Delta B$ < + 4mm
2-rail XX:	- 2mm < ( $\Delta FBX1 + \Delta FBX2$ ) - $\Delta B$ < + 6mm
2-rail XQX:	- 4mm < ( $\Delta FBX1 + \Delta FBQ + \Delta FBX2$ ) - $\Delta B$ < + 8mm
2-rail QXQ:	- 2mm < ( $\Delta FBQ1 + \Delta FBX + \Delta FBQ2$ ) - $\Delta B$ < + 4mm
2-rail QXXQ:	- 4mm < ( $\Delta FBQ1 + \Delta FBX1 + \Delta FBX2 + \Delta FBQ2$ ) - $\Delta B$ < + 6mm
2-rail XXXX:	- 4mm < ( $\Delta FBX1 + \Delta FBX2 + \Delta FBX3 + \Delta FBX4$ ) - $\Delta B$ < + 10mm
3-rail XXQ:	- 4mm < ( $\Delta FBX1 + \Delta FBX2 + \Delta FBQ$ ) - $\Delta B$ < + 6mm
3-rail XXX:	- 4mm < ( $\Delta FBX1 + \Delta FBX2 + \Delta FBX3$ ) - $\Delta B$ < + 8mm
3-rail QXXXXQ:	- 8mm < ( $\Delta FBQ1 + \Delta FBX1 + \Delta FBX2 + \Delta FBX3 + \Delta FBX4 + \Delta FBQ2$ ) - $\Delta B$ < + 10mm
3-rail XXXXXX:	- 8mm < ( $\Delta FBX1 + \Delta FBX2 + \Delta FBX3 + \Delta FBX4 + \Delta FBX5 + \Delta FBX6$ ) - $\Delta B$ < + 14mm

## II.1.2.6 Installatie toleranties

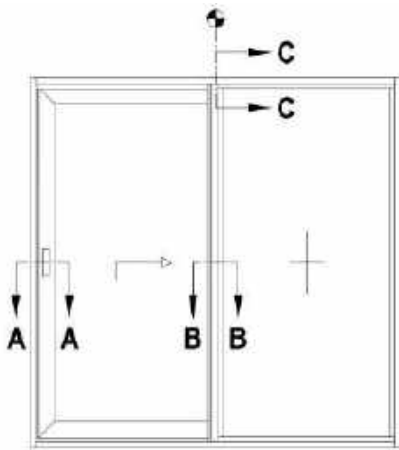

**A-A**

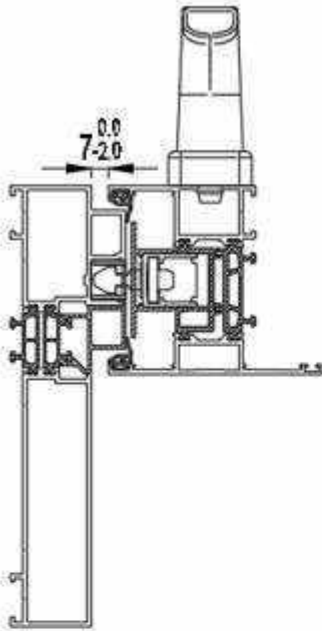

**B-B**

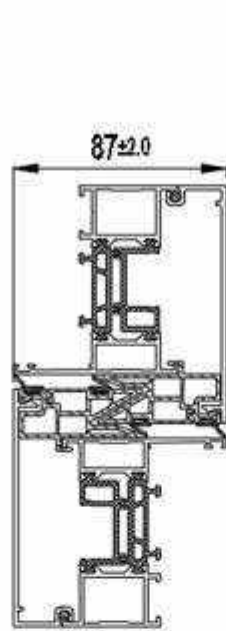

**C-C (\*)**

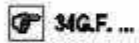
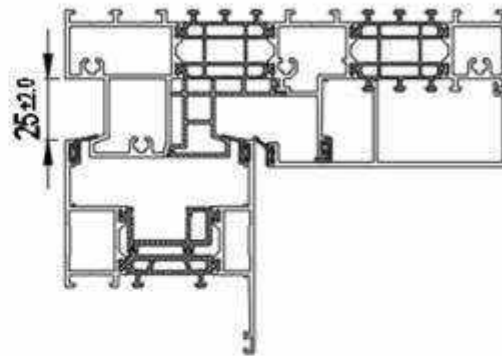

Afregelen van sluitpunten

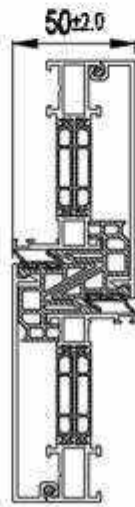

\* Bij elke wisselprofiel positie moet de afstand tussen de vleugel en de kader  $25 \pm 2$ mm zijn.

## II.2 MONTAGEVOORSCHRIFTEN

### II.2.1 Stockage

De stockage van onafgewerkte of afgewerkte elementen dient steeds in een droge, vorstvrije ruimte te gebeuren

### II.2.2 Inbouw in de ruwbouw

De bevestiging aan de ruwbouw gebeurt ofwel rechtstreeks doorheen de profielen met bijvoorbeeld schroeven en pluggen, ofwel met behulp van bevestigingsankers.

- De bevestigingen mogen niet minder dan 40 mm van de wand van de ruwbouw worden aangebracht.
- De verankering mag geenszins het draagvermogen van de aangrenzende bouwoonderdelen beïnvloeden.
- Alle verankeringen, voor zover niet uit aluminium of roestvrij staal, dienen afdoende tegen corrosie te zijn beschermd en mogen zelf ook geen aantasting van het aluminium veroorzaken.
- Bij de plaatsing van de schuifelementen worden er voldoende bevestigingen voorzien:

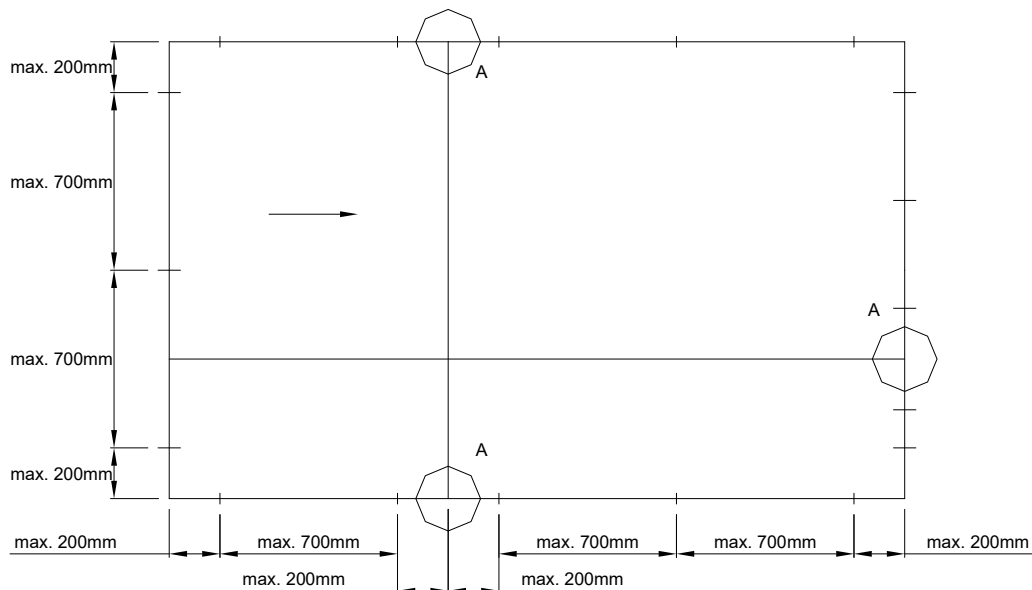

Er dienen aan alle zijden minstens 2 bevestigingen aangebracht te worden met een maximale afstand tot de hoek van 200 mm.

- De afstand van de bevestigingen onderling bedraagt maximum 700 mm.
- Op de plaatsen waar een tussenregel of tussenstijl op de zijstijl, boven- of onderregel aansluit, moet de verankering op maximum 200 mm naast de stijl- of regelaansluiting worden aangebracht. (A). Hierdoor wordt bereikt dat de tussenregel en de tussenstijl een lengteverandering (ten gevolge van temperatuurverandering) zonder schade kunnen ondergaan. Aan te raden is de bevestigingen te positioneren ter hoogte van ieder sluitpunt.

Opmerking: De verankeringen dienen dusdanig aangebracht te worden dat ze eventuele zettingen van het schuifelement kunnen opvangen.

Bij gebruik van schroeven en pluggen doorheen de profielen mogen de kamers in het onderste vast kader niet doorboord worden om geen waterinfiltratie te bekomen ter hoogte van deze bevestiging.

### II.2.3 Inbouw van het beslag

Keuze van bevestigingspunten, aantal sluitpunten, max. Vleugelgewicht, max. Vleugelafmetingen, toegepast vleugelprofiel e.a. dient te gebeuren volgens de richtlijnen van de systeemleverancier en de beslagfabrikant.

Glijdende en bewegende delen zijn van neutraal vet te voorzien.

Bij montage controleren of het beslag soepel en zonder hapering te bedienen is.

### II.3 BEGLAZING

Al onze systemen zijn ontworpen voor beglazing met EPDM-rubbers of neutrale siliconenkit. Bij siliconenbeglazing dient een rugvulling aangebracht te worden om een correcte opening tussen het glaspaneel en het aluminiumkader te creëren. Wij raden u aan onze speciaal ontwikkelde beglazingsrubbers te gebruiken. De beglazing hiermee zal vlotter en betrouwbaar verlopen, duurzamer zijn in de tijd, en beschadigde glaspanelen zullen gemakkelijker vervangen kunnen worden.

Bij de beglazing dient rekening te worden gehouden met volgende punten:

- Door opstuiken van de rubber wordt vermeden dat er daarna openingen ontstaan in de hoeken.
- Drainagegaten dienen geboord te worden om waterophoping te vermijden. Dit is ook noodzakelijk bij siliconenbeglazing (zie drainagetekeningen).
- Voor het plaatsen van het glas dient rekening gehouden te worden met een speling van minimum 12 mm op het aluminiumraam (6 mm per zijde).
- De glassteunen die zich aan de onderzijde van het glaspaneel bevinden, dienen afgedicht te worden (zie tekeningen hieronder). Bij dubbele en driedubbele beglazing moet extra aandacht besteed worden aan de manier waarop de silicone wordt aangebracht.

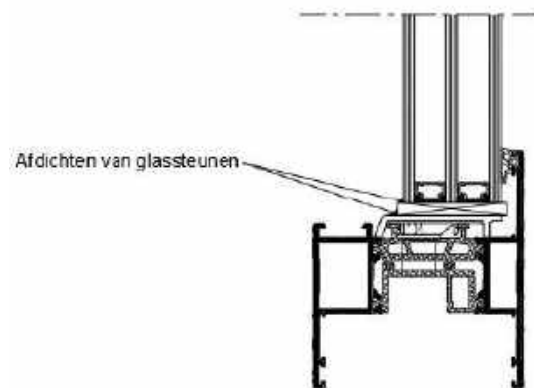

Bevestiging van de beglazing.

Geen enkel glaspaneel mag rechtstreeks in contact komen met aluminium zonder tussenplaatsing van beglazingsblokjes en een rubberdichting.

Door het opspieën van het glas vermijdt men niet enkel dit contact, maar wordt eveneens een juiste plaatsing in het schuifelement bekomen en het eigen gewicht van het glas wordt op de juiste wijze overgebracht naar de wielen teneinde een eventuele vervorming van de vleugel te voorkomen.

Om het vastzetten te vereenvoudigen, beschikken wij over glassteunen die gebruikt worden om de bodem te effenen. Hierop kan men dan rechthoekige beglazingsblokjes plaatsen.

Bij dubbele en driedubbele beglazing moet extra aandacht besteed worden dat het glas steeds over de volledige glasdikte ondersteund wordt en dat de steunblokjes (C1) voldoende sterk zijn om het volledige glasgewicht te kunnen dragen.

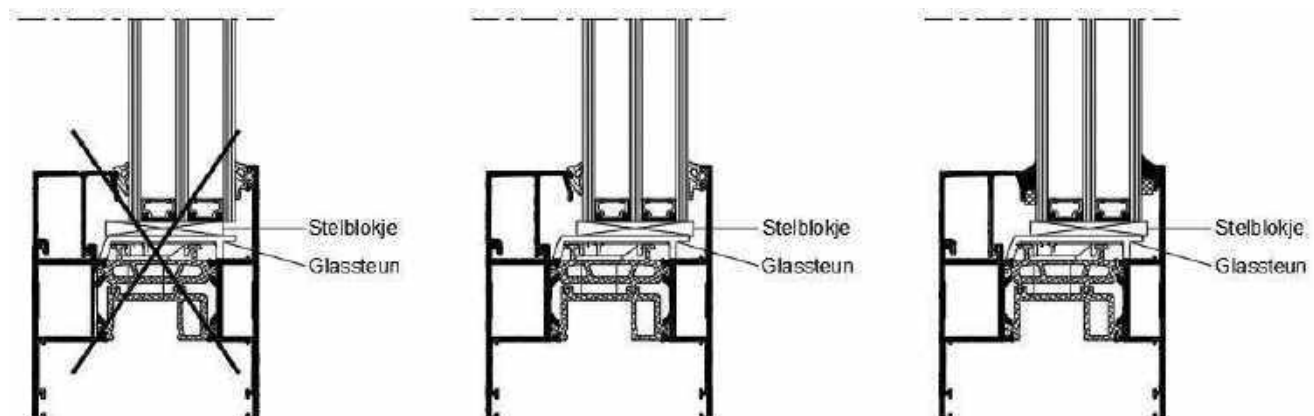

Het aantal en de plaats van de beglazingsblokjes wordt bepaald door norm STS38.

Een overzicht:

In de beglazingsblokjes onderscheiden wij 2 types:

steunblokjes



stelblokjes

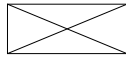

### C1: Steunblokjes

Deze blokjes brengen het gewicht van het glas over op de vleugel of het raamkozijn. Hun goede plaatsing is van groot belang voor de werking van de schuifelementen.

### C2: Stelblokjes

Deze blokjes verzekeren de positionering van het glas tussen de sponning. Ze worden aangebracht zonder forceren. Hun doel is elke beweging van het glas in zijn vlak uit te schakelen.

De volgende schetsen geven de plaatsing van de beglazingsblokjes in de verschillende types schuifelementen aan.

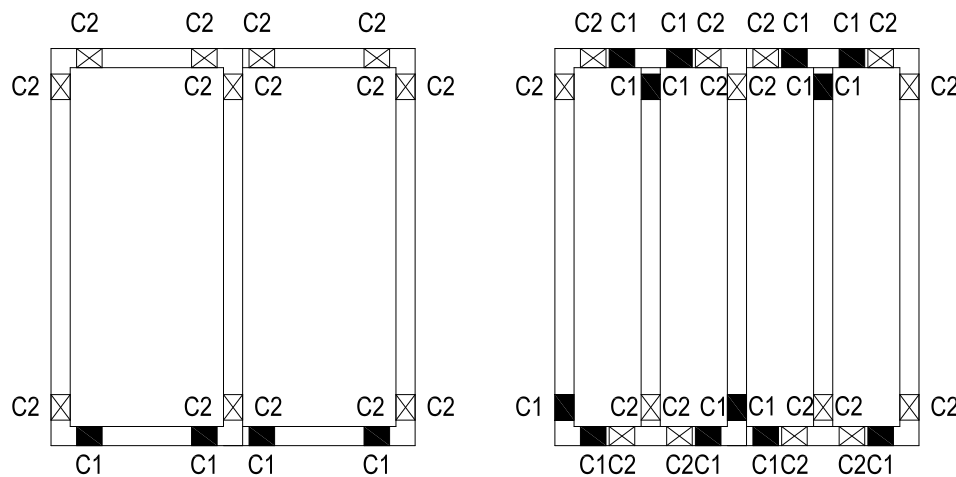

Bij schuivende vleugels dient het glasgewicht overgebracht te worden naar de wielen. De steunblokjes (C1) moeten dus onderaan geplaatst worden ter hoogte van de wielen.

Bij vaste vleugels dient het glasgewicht overgebracht te worden naar het steunstuk van de vaste vleugel. De steunblokjes moeten dus geplaatst worden ter hoogte van het steunstuk.

Bij vaste beglazing monorail brengt men de ondersteuning aan in de hoeken van de onderregel om te beletten dat deze gaat doorbuigen onder het gewicht van het glas (zie schets monorail).

Om het vastzetten te vereenvoudigen, beschikken wij over glassteunen die gebruikt worden om de bodem van de sponning te effenen. Hierop kan men dan rechthoekige beglazingsblokjes plaatsen.

## II.4 GEBRUIK

In vergrendelde positie rust de vleugel op steunstukken die deel uitmaken van de wielen basisset. Dit zorgt ervoor dat het gewicht van de vleugel niet gedragen wordt door de wielen. Wanneer de vleugel voor lange tijd geopend wordt (meer dan 8u of meer dan 4u bij +30°C), wordt het aangeraden om de vleugel te laten zakken op de steunstukken zodat er geen vervorming van de wielen optreedt.

Als het gewicht van de vleugel toch langdurig op de wielen heeft gerust, kan er een tijdelijke vervorming van de wielen optreden. Deze vervorming zorgt voor een storend lawaai bij het openen en sluiten van de vleugel. Dit probleem kan worden opgelost door de vleugel een aantal keren kort na elkaar open en dicht te schuiven.

# RECOMMANDATIONS DE MISE EN ŒUVRE

## I. GENERAL

Voir catalogue "1. Informations générales" (099.C01\*.\*\*) )

## II. RECOMMANDATIONS DE MISE EN ŒUVRE MASTERPATIO

### II.1 RECOMMANDATIONS DE FABRICATION

Um ein qualitativ hochwertiges Endprodukt zu erstellen, sollen bei der Verarbeitung folgende Punkte berücksichtigt werden:

#### II.1.1 Opérations d'usinage

Par opérations d'usinage on entend: toutes les opérations mécaniques comme le tronçonnage, le fraisage, le forage, le poinçonnage et la découpe. Il est essentiel que la couche de laque des profils laqués ne se détache pas sur les bords pendant ces opérations.

Il est donc très important pour la qualité des assemblages que:

Les outils d'usinage soient adaptés et suffisamment aiguisés;

Les machines soient bien réglées (p.ex. régime);

Un contrôle régulier des outils ait lieu;

Les outils d'usinage soient correctement et suffisamment graissés:

bâton lubrifiant Reynalube (art. n°. 086.9191.UN) pour lames de scie.

huile de coupe (art. n°. 086.9175.--) pour outils de poinçonnage.

ou les réfrigérants et lubrifiants prescrits par les fournisseurs des machines.

Les mors de serrage adaptés soient utilisés (voir détails de fabrication « blocs de serrage »);

La table d'amenée ou d'évacuation soit exempte de copeaux et de souillures;

Le refroidissement éventuel se fasse à l'aide de produits chimiquement neutres qui ne corrodent pas le traitement de surface.

Dans un souci de bon fonctionnement, de performance et d'esthétique du produit fini, il est très important de tronçonner les profilés dans des tolérances étroites. En cas d'incertitude quant à ce qu'il faut entendre par tolérances acceptables, on consultera les directives d'organismes tels que Aluminium Center Belgium.

Position / serrage des profils pendant le tronçonnage:

La position des profils sur la table de sciage pendant le tronçonnage est très importante et est la base pour obtenir des onglets parfaits après montage des éléments coulissants.

La pression principale doit toujours être exercée sur la "face de référence" des profils..

La "face de référence" doit être positionnée parfaitement horizontalement ou verticalement sur la table de sciage.

Les mors de serrage doivent éventuellement être utilisés:

- Pour éviter que les tolérances sur les profils influencent la qualité de l'onglet;
- Pour éviter que les profils ne basculent sur la table.

Face de référence ->

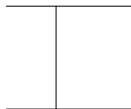

<- Face de référence

#### MAUVAIS TRONÇONNAGE

DEFAULT: Le vérin principal presse sur la surface visible du profile à tronçonner entraînant son décalage.

CONSEQUENCES: Coupe d'onglet en biais, côtés extérieurs raccourcis par rapport aux côtés intérieurs.

RESULTAT: Après sertissage, l'assemblage sur la face intérieure est correct, tandis qu'à l'extérieur l'onglet s'est ouvert.

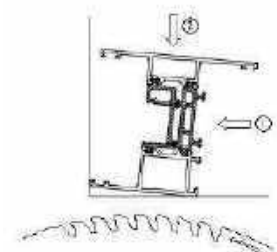

#### TRONÇONNAGE CORRECT

Le vérin principal exerce sa pression sur la face de la feuillure.

La surface visible ne subit que la pression réduite du vérin secondaire.

Le profilé n'a pas tendance à se décaler ou à se déformer pendant la coupe et le sertissage des profilés sciés à onglet peut s'effectuer sans problèmes.

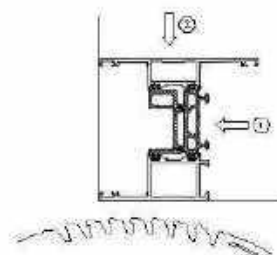

## Remarque:

Il est recommandé d'aspirer les copeaux pendant le tronçonnage.

Toutes les coupes des profilés qui forment une jonction comme les équerres d'assemblage angulaires et les jonctions-T doivent être protégées à l'aide de Reynaprotector .

Toutes les autres coupes (comme parcloses, fixations, ...) doivent être protégées à l'aide de Reynaers Anti-Corro (art.no. 086.9606.--) ainsi que les fraisages, trous d'alésage, perforations, ...

**II.1.2 Assemblage**

Nous faisons la subdivision suivante:

1. raccords d'angle
  - A sertir
  - A visser
  - A goupiller
2. assemblages T
3. drainage et découpes pour les accessoires;
4. joints.

**II.1.2.1 Raccords d'angle**

Avant de faire les raccords d'angle, il faut vérifier que tous les opérations d'usinage nécessaires à l'assemblage de la porte ou de la fenêtre sont bien faites. Certaines opérations ne sont pas possibles à faire après.

**II.1.2.1.1 A sertir**

Étapes :

- a. Tronçonnage parfait.
- b. Protection des coupes et des surfaces traitées par:
  - ébavurage (si nécessaire);
  - enlèvement des poussières et des copeaux de sciage sur la coupe et dans la chambre du profilé.
- c. dégraissage (Reynafinish 60 art. n°. 086.9210.-- ou Reynaers safety clean 086.9231.--);  
application de Reynaprotector sur des copeaux de sciage et Reynaers Anti Corro (art.no. 086.9606.--) sur des copeaux de fraisage
- d. Encollage dans la chambre du profilé: appliquer une colle d'étanchéité approuvée (Reynaseal duo art. n°. 084.9080.--).
- e. Application des équerres à sertir et des équerres de remplissage.
- f. Raccorder et sertir.

Sur les éléments composés, les résidus de colle ne doivent être enlevés que des surfaces visibles, et ceci uniquement à l'aide d'un produit non-agressif (Reynafinish 60 art. n°. 086.9210.-- ou Reynaers safety clean 086.9231.--);

Remarques:

Afin d'obtenir une bonne étanchéité du dormant, une fermeture doit être montée entre le raccord d'angle droit.

**II.1.2.1.2 A visser**

Étapes:

- a. Tronçonnage parfait.
- b. Application des trous à visser.
- c. Protection des coupes et des surfaces traitées par:
  - ébavurage (si nécessaire);
  - enlèvement des poussières et des copeaux de sciage sur la coupe et dans la chambre du profilé.
- d. dégraissage (Reynafinish 60 art. n°. 086.9210.-- ou Reynaers safety clean 086.9231.--);
  - e. application de Reynaprotector sur des copeaux de sciage et Reynaers Anti-Corro (art.no. 086.9606.--) sur des copeaux de fraisage
- e. Encollage dans la chambre du profilé: appliquer une colle d'étanchéité approuvée (Reynaseal duo art. n°. 084.9080.--).
- f. Application des équerres à visser et des équerres de remplissage.
- g. Raccorder et visser et goupiller.
- h. Sur les éléments composés, les résidus de colle ne doivent être enlevés que des surfaces visibles, et ceci uniquement à l'aide d'un produit non-agressif (Reynafinish 60 art. n°. 086.9210.-- ou Reynaers safety clean 086.9231.--);

Remarques:

- Afin d'obtenir une bonne étanchéité du dormant, une fermeture doit être montée entre le raccord d'angle droit.

### II.1.2.1.3 A goupiller

Etales:

- a. Tronçonnage parfait.
- b. Application des trous à goupiller.
- c. Protection des coupes et des surfaces traitées par:  
ébavurage (si nécessaire);  
enlèvement des poussières et des copeaux de sciage sur la coupe et dans la chambre du profilé.
- d. dégraissage (Reynafinish 60 art. n°. 086.9210.-- ou Reynaers safety clean 086.9231.--);
- e. application de Reynaprotector sur des copeaux de sciage et Reynaers Anti-Corro (art.no. 086.9606.--) sur des copeaux de fraisage
- f. Encollage dans la chambre du profilé: appliquer une colle d'étanchéité approuvée (Reynaseal duo art. n°. 084.9080.--).
- g. Application des équerres à visser et des équerres de remplissage.
- h. Raccorder et goupiller.
- i. Sur les éléments composes, les résidus de colle ne doivent être enlevés que des surfaces visibles, et ceci uniquement à l'aide d'un produit non-agressif (Reynafinish 60 art. n°. 086.9210.-- ou Reynaers safety clean 086.9231.--);

Remarques:

Afin d'obtenir une bonne étanchéité du dormant, une fermeture doit être montée entre le raccord d'angle droit.

### II.1.2.2 Assemblage T

Etales:

- a. Tronçonnage parfait de la traverse.
- b. Application des trous des raccordement-T
- c. Fraiser la hauteur de la rainure de la traverse
- d. Protection des coupes et des surfaces traitées par:  
ébavurage (si nécessaire);  
enlèvement des poussières et des copeaux de sciage sur la coupe et dans la chambre du profilé;
- e. dégraissage (Reynafinish 60 art. n°. 086.9210.-- ou Reynaers safety clean 086.9231.--);
- f. application de Reynaprotector
- g. Etanchement de la traverse : appliquer de la matière d'étanchéité neutre :  
sur les coupes;  
sur les trous de fixation;
- h. Etanchement de la zone au dessous des traverses sur le profilé dormant en appliquant des éléments d'étanchéité ou d'une matière neutre.  
Ceux-ci doivent être complètement étanches à l'eau. (monorail)
- i. Assemblage: la jonction T est positionnée sur la ligne de centrage, la traverse est introduit, vissée et chevillée (ou 2x chevillée).
- j. Sur les éléments composes, les résidus de matière d'étanchéité ne doivent être enlevés que des surfaces visibles, et ceci uniquement à l'aide d'un produit non-agressif (Reynafinish 60 art.n°. 086.9210.-- ou Reynaers safety clean 086.9231.--);

### II.1.2.3 Drainage, aération et découpes pour les accessoires Verfahrensweise:

Etales:

- a. Marquer les découpes.
- b. Poinçonnage, forage ou fraisage correct.
- c. Protection des surfaces traitées par:  
- ébavurage (si nécessaire);  
- enlèvement des poussières et des copeaux sur les scies et dans la chambre du profilé
- d. dégraisse (Reynafinish art. n°. 086.9210.-- ou Reynaers safety clean 086.9231.--); application de Reynaprotector

Lors du drainage / aération, il faut prêter attention aux points suivants:

Les eaux d'infiltration éventuelles doivent être évacuées de façon rapide et contrôlée vers l'extérieur et il faut maintenir la chambre de décompression à la pression atmosphérique.

Pour chaque élément coulissant, des ouvertures de drainage sont prévues à une distance maximale de l'angle de 250 mm pour l'ouvrant et de 150 mm pour le dormant. La distance maximale entre 2 ouvertures de drainage est de 800 mm.

Pour chaque surface vitrée il faut prévoir 2 trous de drainage !

Il faut toujours drainer au niveau de point le plus bas de la feuillure de vitrage.

Les éléments coulissants, quel que soit leur type, doivent obligatoirement être drainées au niveau des traverses basses et intermédiaires.

Les ouvertures pour l'ouvrant, la surface minimale de ces ouvertures est de 50 mm<sup>2</sup> par ouverture, soit sous forme d'une ouverture ronde avec un diamètre minimal de 8 mm, doit sous forme d'une ouverture ovale de 5 mm X 15 mm au minimum.

Pour le dormant, la surface minimale est de 150 mm<sup>2</sup> par ouverture, soit sous forme de 3 ouvertures rondes avec un diamètre minimal de 8 mm, soit sous forme d'ouverture ovale de 8 mm X 34 mm au minimum.  
Les ouvertures de drainage qui sont visibles de l'extérieur de l'élément coulissant doivent recevoir des capuchons en matière synthétique.

Chaque élément coulissant doit être prévue de trous d'aération. Sa fonction est de garantir l'égalisation de la pression autour du vitrage.

Sur le haut du côté de l'ouvrant, on fore toujours au moins 1 trous d'aération de Ø8mm de diamètre au minimum.  
(Voir G34.f. ...)

Pour les ouvrants fixes, le joint extérieur (180.9114.SY) doit être interrompu sur une distance de 50 mm.

Remarque: Pour des drainages spécifiques, nous nous référons à la page G34.f. ...

#### **II.1.2.4 Joints**

Tous les joints sont en EPDM résistant aux intempéries et au vieillissement. Leur montage doit se faire soigneusement, puisque l'étanchéité de l'élément coulissant en dépend.

##### **a. Application des joints/joints de vitrage**

Etapes:

1. Découpe correcte: la découpe du joint de vitrage doit se faire avec des ciseaux spéciaux (art. n°. 090.0121.UN) et le joint peut être coupé à onglet ou droit en fonction du type de jonction entre les profilés. Une longueur supplémentaire (environ 10 mm par mètre) doit être prévue.
2. Application du joint: les joints sont appliqués dans les rainures des profils prévues à cet effet; la longueur supplémentaire est légèrement refoulée pour neutraliser la dilatation ou le rétrécissement. Les difficultés de mise en place peuvent être résolues à l'aide d'un aérosol silicone (art. n°. 086.9551.--).
3. Encollage (étanchement): dans les angles, le joint de vitrage doit être encollé sur les coins avec de la colle de vulcanisation (art. n°. 084.9108.04).

##### **b. Application des brosses.**

Etapes:

1. Découpe correcte: la découpe de la brosse doit se faire avec des ciseaux spéciaux (art. n° 090.0121.UN) et le joint peut être coupé à onglet ou droit en fonction du type de jonction entre les profilés.
2. Application de la brosse: les brosses sont appliqués dans les rainures des profils prévues à cet effet.
3. Encollage: En fonction du type de jonction entre les profils (droit), la brosse doit être encollée aux extrémités avec de la colle rapide (Reynaglue art. n°. 084.9107.--). Cet encollage est nécessaire pour éviter le glissement de la brosse.

##### **c. Application d'une fermeture en bas et en haut de la chicane.**

Afin d'obtenir une bonne étanchéité à l'eau et au vent, une fermeture supplémentaire doit être montée en bas et en haut de la chicane:

## II.1.2.5 Tolérances de fabrication

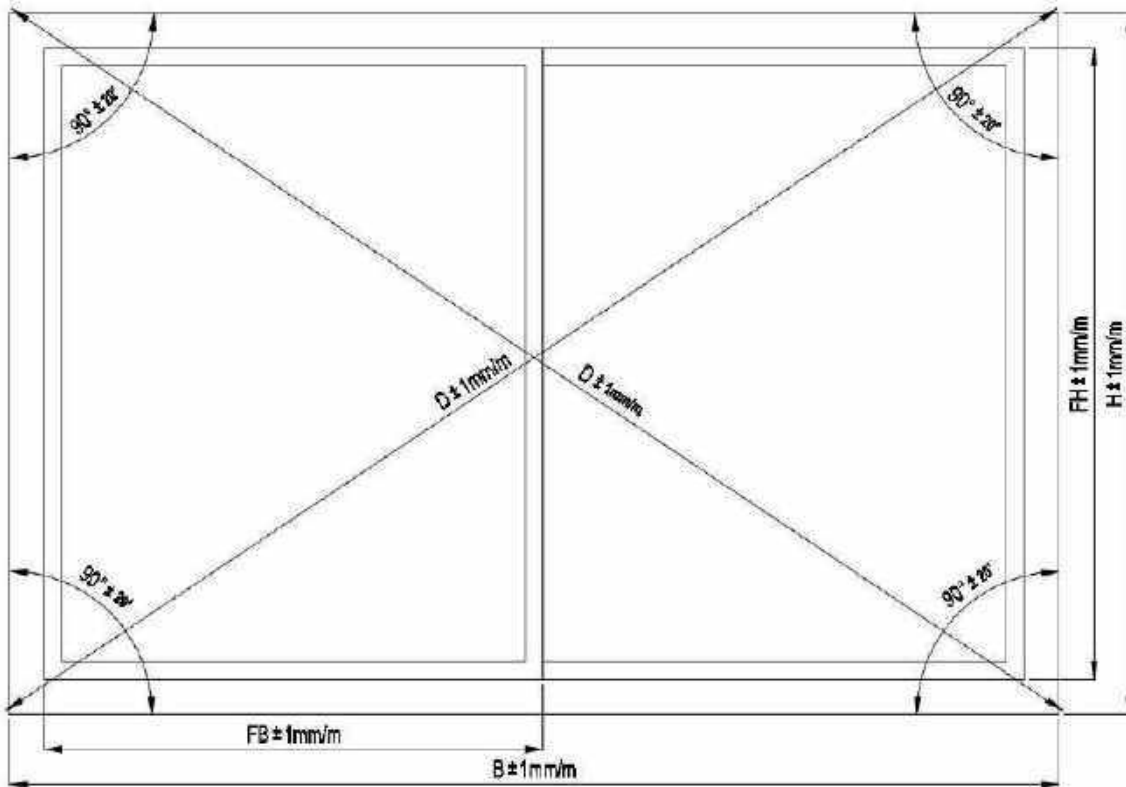

$$- 1\text{mm} < \Delta H - \Delta FH < + 1\text{mm}$$

Monorail XQ:	- 2mm < ( $\Delta FBX + \Delta FBQ$ ) - $\Delta B$ < + 4mm
Monorail XQX:	- 4mm < ( $\Delta FBX1 + \Delta FBQ + \Delta FBX2$ ) - $\Delta B$ < + 8mm
Monorail QXQ:	- 2mm < ( $\Delta FBQ1 + \Delta FBX + \Delta FBQ2$ ) - $\Delta B$ < + 4mm
Monorail QXXQ:	- 4mm < ( $\Delta FBQ1 + \Delta FBX1 + \Delta FBX2 + \Delta FBQ2$ ) - $\Delta B$ < + 6mm
2-rail XQ:	- 2mm < ( $\Delta FBX + \Delta FBQ$ ) - $\Delta B$ < + 4mm
2-rail XX:	- 2mm < ( $\Delta FBX1 + \Delta FBX2$ ) - $\Delta B$ < + 6mm
2-rail XQX:	- 4mm < ( $\Delta FBX1 + \Delta FBQ + \Delta FBX2$ ) - $\Delta B$ < + 8mm
2-rail QXQ:	- 2mm < ( $\Delta FBQ1 + \Delta FBX + \Delta FBQ2$ ) - $\Delta B$ < + 4mm
2-rail QXXQ:	- 4mm < ( $\Delta FBQ1 + \Delta FBX1 + \Delta FBX2 + \Delta FBQ2$ ) - $\Delta B$ < + 6mm
2-rail XXXX:	- 4mm < ( $\Delta FBX1 + \Delta FBX2 + \Delta FBX3 + \Delta FBX4$ ) - $\Delta B$ < + 10mm
3-rail XXQ:	- 4mm < ( $\Delta FBX1 + \Delta FBX2 + \Delta FBQ$ ) - $\Delta B$ < + 6mm
3-rail XXX:	- 4mm < ( $\Delta FBX1 + \Delta FBX2 + \Delta FBX3$ ) - $\Delta B$ < + 8mm
3-rail QXXXXQ:	- 8mm < ( $\Delta FBQ1 + \Delta FBX1 + \Delta FBX2 + \Delta FBX3 + \Delta FBX4 + \Delta FBQ2$ ) - $\Delta B$ < + 10mm
3-rail XXXXXX:	- 8mm < ( $\Delta FBX1 + \Delta FBX2 + \Delta FBX3 + \Delta FBX4 + \Delta FBX5 + \Delta FBX6$ ) - $\Delta B$ < + 14mm

## II.1.2.6 Tolérances d'installation

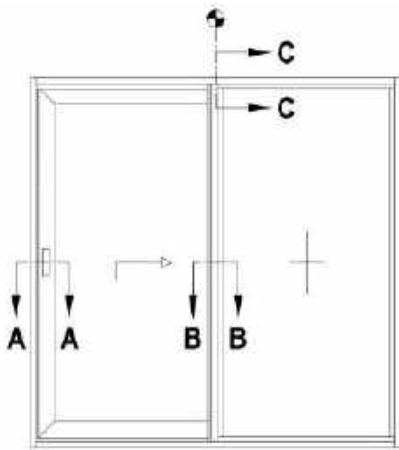

**A-A**

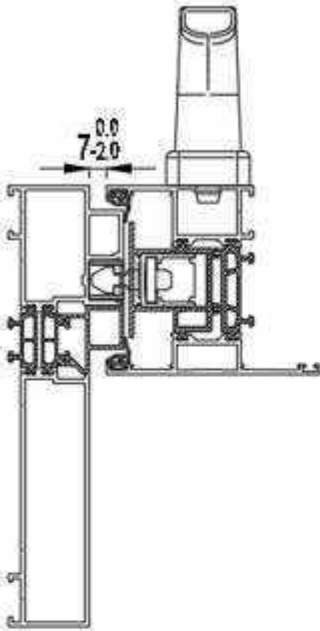

**B-B**

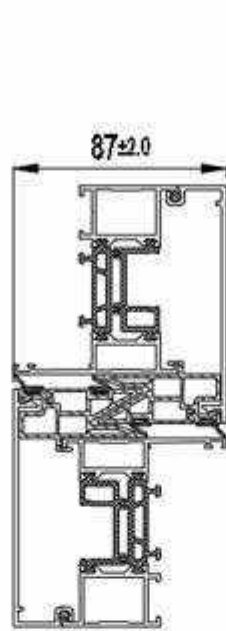

**C-C (\*)**

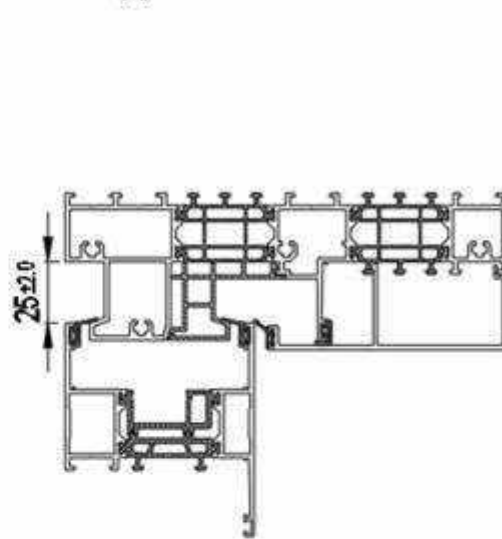

Régler les points de verrouillage

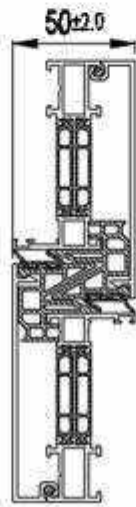

\* Dans chaque position de chicane, la distance entre l'ouvrant et le cadre doit être de  $25 \pm 2$ mm.

## II.2 RECOMMANDATIONS DE MONTAGE

### II.2.1 Stockage

Les éléments non finis et finis doivent seulement être stockés dans un local sec, à l'abri du gel.

### II.2.2 Montage dans le gros œuvre

La fixation au gros œuvre se fait soit directement à travers les profils avec par exemple des vis et des chevilles, soit à l'aide d'ancrages de fixation.

- Les fixations ne peuvent pas être appliquées à une distance inférieure à 40 mm du mur du gros œuvre.
- L'ancrage ne peut surtout pas influencer la force portante des éléments de construction contigus.
- Tous les ancrages, pour autant qu'ils ne soient pas en aluminium ou en acier inoxydable, doivent être efficacement protégés contre la corrosion et ne peuvent pas corroder l'aluminium.
- Lors de la pose des éléments coulissants, on prévoit des fixations en suffisance:

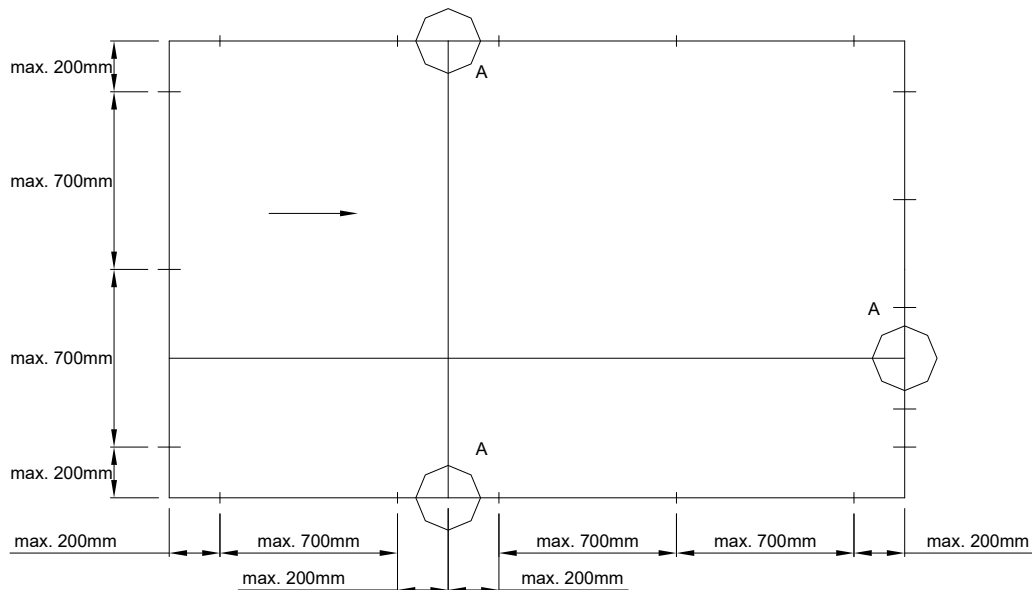

De tous les côtés il doit y avoir au moins 2 fixations avec une distance maximale jusqu'à l'angle de 200 mm.

- La distance entre les fixations est de 700 mm au maximum.
- A l'endroit où des profils T et des profils dormants se rencontrent, l'ancrage doit être appliqué à une distance maximale de 200 mm des deux côtés de profilé T (A).  
De cette façon, une dilatation ou un rétrécissement du profilé T (dus aux fluctuations de température) sont possibles sans dégâts.

- Il est conseillé de positionner les fixations à la hauteur de chaque point de fermeture.

Remarque: Les ancrages doivent être appliqués d'une telle façon qu'ils peuvent neutraliser des dilatations / rétrécissements éventuels de l'élément coulissant.

Si des vis et des chevilles sont utilisées à travers les profils, les Chambers dans le dormant inférieur ne peuvent pas être percées afin d'éviter de l'infiltration d'eau à la hauteur de cette fixation.

### II.2.3 Montage des accessoires

Le choix des points de fixation, du nombre de points de fermeture, du poids max. D'ouvrant, des dimensions max. d'ouvrant, du profilé ouvrant appliqué, etc. doit se faire suivant les introductions du fournisseur des systèmes et du fabricant des accessoires.

Les parties coulissantes et mobiles doivent être pourvues de graisse neutre.

Lors du montage, il faut contrôler si les accessoires peuvent être actionnés de façon souple et sans bloquer.

## II.3 VITRAGE

Tous nos systèmes sont conçus pour vitrer à l'aide de joints d'EPDM ou de silicone neutre. En cas d'utilisation d'un joint en silicone, l'usage d'un fond de joint constitué d'un joint-mousse compressible autocollant est recommandé pour maintenir un espace libre suffisant entre le verre et l'aluminium. Nous vous recommandons d'utiliser notre système de joints de vitrage pour des raisons de facilité et fiabilité de mise en œuvre, de bonne tenue dans le temps et de simplicité dans le remplacement de volumes verriers.

Le vitrage devra se faire en respectant les points suivants:

- Le joint doit être refoulé pour éviter qu'apparaissent, dans le temps, des ouvertures dans les angles dues au rétrécissement de ce joint.
- Des ouvertures de drainage doivent être forées afin d'éviter toute stagnation d'eau. Ceci est également nécessaire en cas de vitrage en silicone (voir schémas de drainage).
- Pour la pose des vitrages, le jeu entre vitrage et fond de feuillure doit être de 12 mm (6mm par côté) au minimum.
- Les supports de vitrage qui se trouvent en –dessous du panneau de vitrage doivent être rendus étanches (voir dessin ci-après). Extra attention pour le vitrage double et triple.

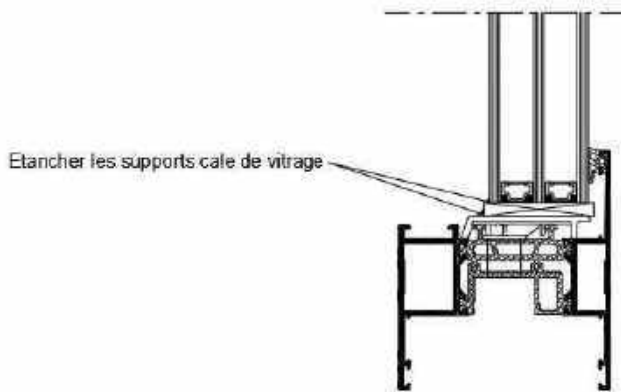

Fixation du vitrage.

Aucun volume verrier ne peut être directement en contact avec l'aluminium. La pose de cales de vitrage et d'un joint est indispensable.

Le but du calage du verre est non seulement d'éviter ce contact, mais également d'obtenir une bonne pose dans l'élément coulissant et de transmettre de façon correcte le poids du verre même sur les galets afin de prévenir une déformation éventuelle de l'ouvrant.

Afin de simplifier le calage du vitrage, nous disposons de supports de vitrage qui sont utilisés pour égaliser le fond de la feuillure. Sur ces supports on peut utiliser des cales de vitrage rectangulaires.

En cas de vitrage double et triple il faut faire attention que le vitrage est complètement supporté sous l'épaisseur totale du vitrage et que les câles de vitrage (C1) sont assez fort pour supporter le poids du vitrage.

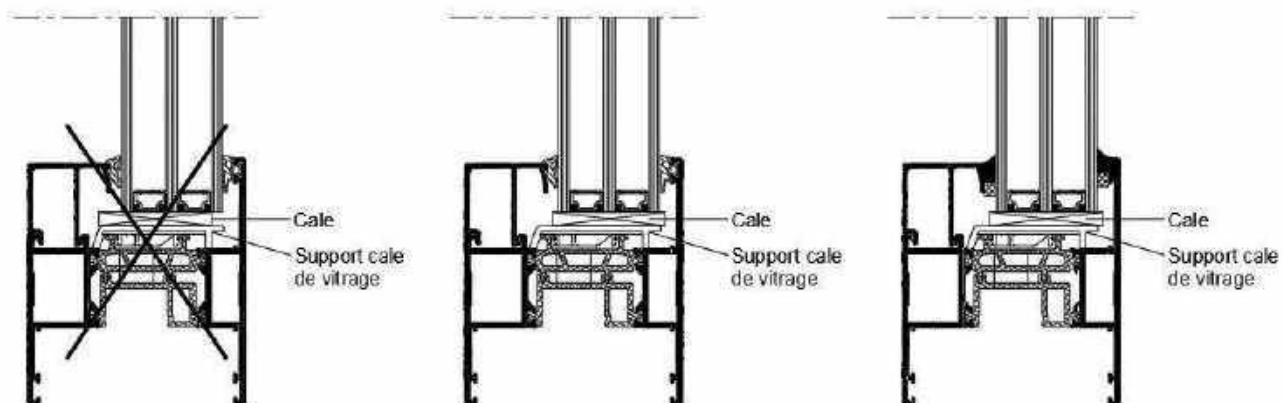

Le nombre et la position des supports de cale de vitrage sont déterminés par le STS 38.  
 Un aperçu :

Nous distinguons 2 types de vitrage:

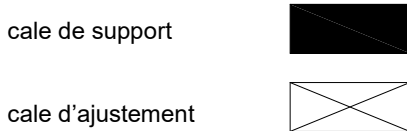

### C1: Cales de support

Ces cales transmettent le poids du verre sur l'ouvrant ou sur l'allège, et leur bonne pose est d'une importance capitale pour le fonctionnement des éléments coulissants.

### C2: Cales d'ajustement

Ces cales assurent le positionnement du verre par rapport à la feuillure, et sont appliqués sans forcer. Elles empêchent tout mouvement du verre dans son logement.

Les schémas suivants indiquent la pose des différentes cales de vitrage dans les différents types d'éléments coulissants.

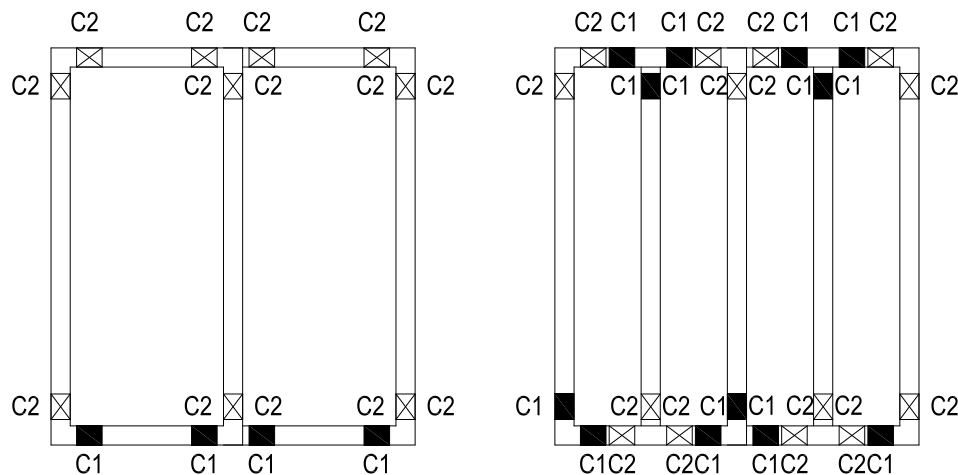

Le poids de vitrage des ouvrants coulissants doit être transmis sur les galets. Les cales de support (C1) doivent donc être montées en bas à la hauteur des galets.

Le poids de vitrage des ouvrants fixes doit être transmis sur la pièce de support de l'ouvrant fixe. Les cales de support (C1) doivent donc être montées à la hauteur de la pièce de support.

En cas de vitrage fixe monorail, on applique les supports dans les angles de la traverse basse pour empêcher que celle-ci ne plie sous le poids du verre (voir schéma monorail).

Afin de simplifier le calage du vitrage, nous disposons de supports de vitrage qui sont utilisés pour égaliser le fond de la feuillure. Sur ces supports on peut utiliser des cales de vitrage rectangulaires.

## II.4 Utilisation

En position verrouillée, le vantail repose sur des supports d'appui intégrés au chariot à roulettes. Ces supports permettent d'éviter que le poids du vantail soit supporté par les roulettes. Lorsque le vantail reste ouvert pendant une durée prolongée (plus de 8h ou plus de 4h à +30°C), il est recommandé de l'abaisser sur les supports d'appui afin que les roulettes ne se déforment pas.

Si toutefois le poids du vantail a reposé pendant un certain temps sur les roulettes, il est possible que ces dernières soient temporairement déformées. Cette déformation produit un bruit gênant lors de l'ouverture et de la fermeture du vantail. Il peut être remédié à ce problème en faisant coulisser le vantail à plusieurs reprises successivement.

B

# PROCESSING DATA

## I. GENERAL

See catalogue “1.General information” (089.C01\*.\*\*)

## II. PROCESSING DATA MASTERPATIO

### II.1 FABRICATING PRESCRIPTIONS

In order to guarantee a perfect end product, the following guidelines should be adhered to during the production process.

#### II.1.1 Metal-removing operations

Metal-removing operations are understood to mean all mechanical operations such as sawing, milling, drilling, punching and cutting. For painted profiles it is essential that the paint coatings do not come off on the edges during these operations. Therefore it is very important for the quality of the connections that:

- The metal-removing tools are appropriate and sufficiently sharp.
- The machines are well adjusted (e.g. number of revolutions).
- The tools are regularly checked.
- The metal-removing tools are greased sufficiently and correctly:
  - Reynalube cutting grease block (art. no. 086.9191.UN) for saw blades.
  - Cutting spray (art. no. 086.9175.--) for punch tools.
  - or the cooling agents and lubricants prescribed by the machine suppliers.
- The appropriate clamp blocks are used. (see assembly drawing “clamp blocks saw”)
- The cutting table is free of swarf and dust.
- Possible cooling is done by means of chemically neutral products which do not attack the surface treatment.

To function correctly, and to achieve the performances and aesthetics of the end product, it is very important that the profiles are sawn within close tolerances. If there is disagreement about what is meant by acceptable deviations, the guidelines of bodies such as the Aluminium Center Belgium can be consulted.

#### Position / clamping of the profiles during cutting:

The position of the profiles on the sawing table during cutting is very important and is the basis to get perfect mitres after assembly of the sliding elements.

The biggest clamping pressure should always be on the “reference side” of the profiles. The “reference side” has to be perfectly horizontally and vertically on the sawing table.

The clamp blocks should be used:

- a. To ensure that tolerances on the profiles do not influence the quality of the mitre.
- b. To ensure that the profiles do not twist on the table.

Reference side ->  <- Reference side

#### INCORRECT CLAMPING

**FAULT:** The clamping pressure is on the upper side of the profile, allowing it to twist during cutting.

**CONSEQUENCE:** An oblique saw cut resulting in the outside of the profile being shorter than the inside.

**RESULT:** On assembly, the corner is closed on the inside and open on the outside..

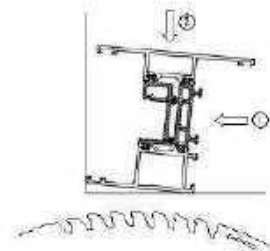

#### CORRECT CLAMPING

Here, the clamping pressure is on the rebate side of the profile, and the visible side undergoes a smaller secondary pressure.

The profile is prevented from twisting or deforming during cutting. A perfect joint is obtained on assembly.

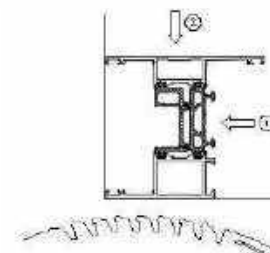

**Remark:**

It is recommended to exhaust the swarf during the cutting.

All the saw cuts that form a joint such as corner joints and T-junctions have to be protected with Reynaprotector

The other saw cuts (such as glazing beads, terminal strips, ...) have to be protected with Reynaers Anti-Corro (art.nr. 086.9606.--) as well as milling cuts, drill holes, punch holes,...

**II.1.2 Assembly**

We make the following subdivisions:

1. Corner connections;
  - Crimping
  - Screwing
  - Pin
2. T-brackets;
3. Drainage, aeration and recesses for the accessories;
4. Gaskets.

**II.1.2.1 Corner connections**

Before the corner connections are made it should be verified that all metal-removing operations required for the assembly of the window have been correctly made. Some of these operations can't be done anymore afterwards.

**II.1.2.1.1 Crimping****Steps:**

- a. Correct sawing.
- b. Protection of the saw cuts and threaded surfaces by:
  - Deburring (if necessary);
  - Removing dust and saw-dust on the saw cut in the profile chamber;
- c. Degreasing (Reynafinish 60 art. no. 086.9210.-- or Reynaers safety clean 086.9231.--); Applying Reynaprotector on the cuttingsurfaces and Reynaers Anti-Corro (art.nr. 086.9606.--) on the millingsurfaces
- d. Applying approved sealing glue in the profile chamber (Reynaseal duo art. no. 084.9080.--).
- e. Applying crimp corner cleats and corner supports.
- f. Making the connection and crimping

The adhesive residue on the visible sides of the completed elements has to be removed by means of a non-aggressive product (Reynafinish 60 art. no. 086.9210.-- or Reynaers safety clean 086.9231.--);

**Remarks:**

To obtain a good sealing of the outer frame a closer should be fitted between the straight corner connection.

**II.1.2.1.2 Screwing****Steps:**

- a. Correct sawing.
- b. Applying screw holes.
- c. Protection of the saw cuts and threaded surfaces by:
  - Deburring (if necessary);
  - Removing dust and saw-dust on the saw cut in the profile chamber;
- d. Degreasing (Reynafinish 60 art. no. 086.9210.-- or Reynaers safety clean 086.9231.--); Applying Reynaprotector on the cuttingsurfaces and Reynaers Anti-Corro (art.nr. 086.9606.--) on the millingsurfaces
- e. Applying approved sealing glue in the profile chamber (Reynaseal duo art. no. 084.9080.--).
- f. Applying screw corner cleats and corner supports.
- g. Making the connection and screwing and pin
- h. The adhesive residue on the visible sides of the completed elements has to be removed by means of a non-aggressive product (Reynafinish 60 art. no. 086.9210.-- or Reynaers safety clean 086.9231.--);

**Remarks:**

To obtain a good sealing of the outer frame a closer should be fitted between the straight corner connection.

**II.1.2.1.3 Pin****Steps:**

- a. Correct sawing.
- b. Applying pin holes.
- c. Protection of the saw cuts and threaded surfaces by:
  - deburring (if necessary);
  - removing dust and saw-dust on the saw cut in the profile chamber;

- d. Degreasing (Reynafinish 60 art. no. 086.9210.-- or Reynaers safety clean 086.9231.--); Applying Reynaprotector on the cuttingsurfaces and Reynaers Anti-Corro (art.nr. 086.9606.--) on the millingsurfaces
- e. Applying approved sealing glue in the profile chamber (Reynaseal duo art. no. 084.9080.--).
- f. Applying screw corner cleats and corner supports.
- g. Making the connection and pin
- h. The adhesive residue on the visible sides of the completed elements has to be removed by means of a non--aggressive product (Reynafinish 60 art. no. 086.9210.-- or Reynaers safety clean 086.9231.--);

## Remarks:

To obtain a good sealing of the outer frame a closer should be fitted between the straight corner connection.

**II.1.2.2 T-brackets**

## Steps:

- a. Correct sawing of the transom-mullion.
- b. Applying T-connection holes
- c. Endmilling of the transom-mullion
- d. Protection of the saw cuts and treated surfaces by:
  - Deburring (if necessary);
  - Removing dust and saw-dust on the saw cut and in the profile chamber;
- e. Degreasing (Reynafinish 60 art. no 086.9210.-- or Reynaers safety clean 086.9231.--);
- f. Applying Reynaprotector.
- g. Sealing of the transom-mullion by applying a neutral sealing agent:
  - On the saw cuts;
  - On the fixing holes;
- h. Sealing of the zone under the trans-mullion on the outer frame by applying sealing elements or a neutral elastic sealing agent.  
These parts should be completely watertight. (monorail)
- i. Making the connection: The T-bracket is positioned, the trans-mullion is inserted, and the T-bracket is fixed with screws and driving-in pins (or 2x driving-in pins).
- j. The sealing agent residue on the visible sides of the completed elements has to be removed by means of a non-aggressive product (Reynafinish 60 art.no. 086.9210.-- or Reynaers safety clean 086.9231.--);

**II.1.2.3 Drainage and recesses for the accessories**

## Steps:

- a. Marking of recesses.
- b. Correct punching, drilling or milling.
- c. Protection of the treated surfaces by:
  - Deburring (if necessary);
  - Removing dust and saw-dust on the saw cuts and in the profile chamber.
- d. Degreasing (Reynafinish 60 art. no. 086.9210.-- or Reynaers safety clean 086.9231.--);
- e. Applying Reynaprotector .

Special attention should be paid to the following regarding drainage / aeration:

Possible infiltrating water must be drained and the profile's chambers has to remain at the atmospheric pressure.

For all sliding elements, drainage holes should be a maximum of 250 mm from the corner for the sliding panel and 150 mm for the outer frame. The maximum distance between 2 drainage holes is 800 mm.

Each glazed surface should be provided with min. 2 drainage holes!

Always drain at the lowest point of the glass rebate.

All types of sliding elements should be provided with a drainage system in the sills and / or the horizontal transoms.

The minimum surface of these openings is 50 mm<sup>2</sup> per opening in the sliding panel, either a round opening of minimum 8 mm diameter, or elongated openings of minimum 5 mm by 15 mm. For the outer frame the minimum surface is 150 mm<sup>2</sup> per opening, either 3 round openings of minimum 8 mm diameter, or an elongated opening of minimum 8 mm by 34 mm.

Drainage holes which are visible on the outside of the sliding element are covered with drainage covers in synthetic material.

All sliding elements are provided with ventilation holes. Its function is to guarantee the pressure equalization around the glazing.

On the side at the top of the sliding panel at least 1 decompressing opening of minimum Ø8mm should be drilled (see pages G34.f. ...)

For fixed panels the outer gasket (180.9114.SY) should be interrupted over a distance of 50 mm.

Remark: For specific drainage we refer to pages G34.f. ...

## II.1.2.4 Gaskets

All gaskets are out of EPDM that is resistant to weathering and ageing. They should be carefully applied since the tight sealing of the sliding elements depends on their correct application.

### a. Applying the gaskets/glazing gaskets

Steps:

1. Correct cutting: the glazing gasket should be cut with special gasket scissors (art. no. 090.0121.UN) and can be cut straight or mittered according to the kind of profile connection. Excess material (about 10 mm per meter) is required.
2. Application of the gasket: the gaskets are applied in the appropriate grooves within the profiles. Difficulties in applying the gasket can be solved by the use of silicone spray (art. no. 086.9551.--).
3. Gluing (sealing): in the corners, glazing gaskets should be glued to the corner pieces with vulcanizing agent (art. no. 084.9108.04). This vulcanizing agent will remain elastic and because of this the gasket will also fit perfectly into the corners.

### b. Applying the brushes.

Steps:

1. Correct cutting: the brush should be cut with special gasket shears (art. no. 090.0121.UN) and can be cut straight or mitred according the kind of profile connection.
2. Application of the brush: the brushes are applied in the appropriate grooves within the profiles.
3. Gluing: In function of the type of profile connection (straight), the brush should be glued at the ends with contact glue (Reynaglue art. no. 084.9107.--). This gluing is necessary to avoid the slipping away of the brush.

### c. Applying a closer at the bottom and the top of the meeting section

To obtain a good water tightness, an extra closer should be fitted at the bottom and top of the meeting section.

## II.1.2.5 Fabrication tolerances

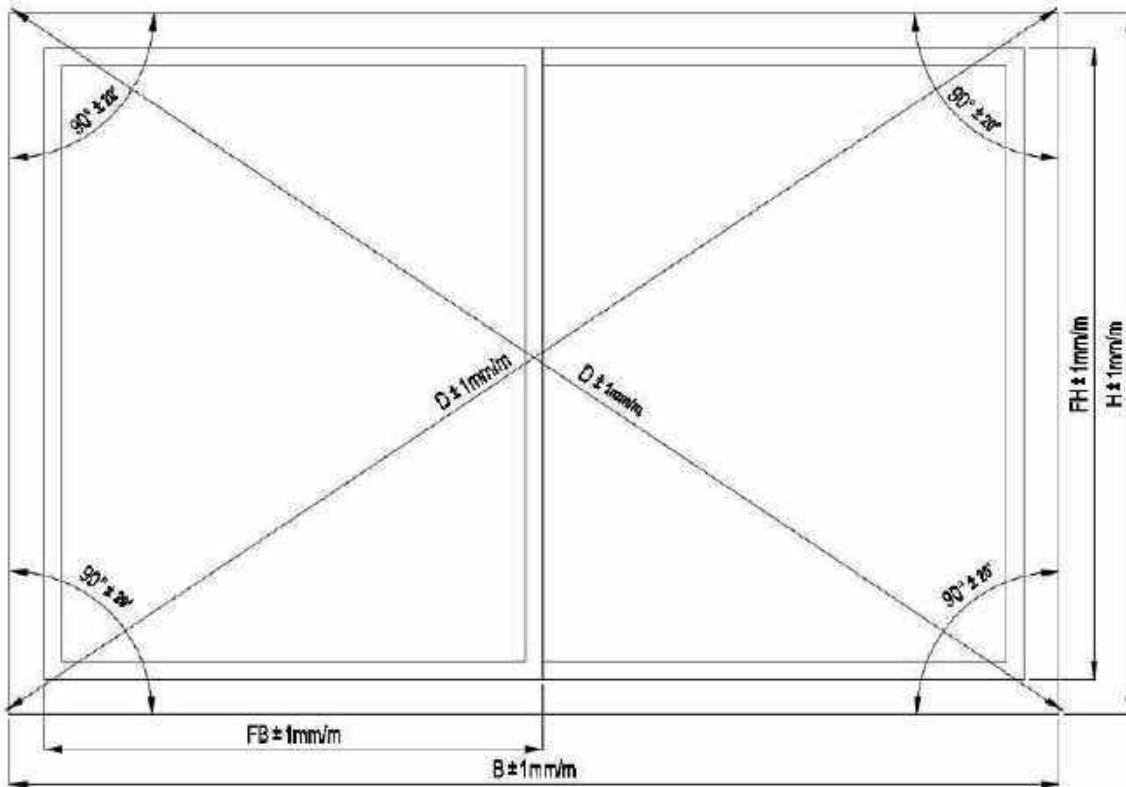

$$- 1\text{mm} < \Delta H - \Delta FH < + 1\text{mm}$$

Monorail XQ:	- 2mm < ( $\Delta FBX + \Delta FBQ$ ) - $\Delta B$ < + 4mm
Monorail XQX:	- 4mm < ( $\Delta FBX1 + \Delta FBQ + \Delta FBX2$ ) - $\Delta B$ < + 8mm
Monorail QXQ:	- 2mm < ( $\Delta FBQ1 + \Delta FBX + \Delta FBQ2$ ) - $\Delta B$ < + 4mm
Monorail QXXQ:	- 4mm < ( $\Delta FBQ1 + \Delta FBX1 + \Delta FBX2 + \Delta FBQ2$ ) - $\Delta B$ < + 6mm
2-rail XQ:	- 2mm < ( $\Delta FBX + \Delta FBQ$ ) - $\Delta B$ < + 4mm
2-rail XX:	- 2mm < ( $\Delta FBX1 + \Delta FBX2$ ) - $\Delta B$ < + 6mm
2-rail XQX:	- 4mm < ( $\Delta FBX1 + \Delta FBQ + \Delta FBX2$ ) - $\Delta B$ < + 8mm
2-rail QXQ:	- 2mm < ( $\Delta FBQ1 + \Delta FBX + \Delta FBQ2$ ) - $\Delta B$ < + 4mm
2-rail QXXQ:	- 4mm < ( $\Delta FBQ1 + \Delta FBX1 + \Delta FBX2 + \Delta FBQ2$ ) - $\Delta B$ < + 6mm
2-rail XXXX:	- 4mm < ( $\Delta FBX1 + \Delta FBX2 + \Delta FBX3 + \Delta FBX4$ ) - $\Delta B$ < + 10mm
3-rail XXQ:	- 4mm < ( $\Delta FBX1 + \Delta FBX2 + \Delta FBQ$ ) - $\Delta B$ < + 6mm
3-rail XXX:	- 4mm < ( $\Delta FBX1 + \Delta FBX2 + \Delta FBX3$ ) - $\Delta B$ < + 8mm
3-rail QXXXXQ:	- 8mm < ( $\Delta FBQ1 + \Delta FBX1 + \Delta FBX2 + \Delta FBX3 + \Delta FBX4 + \Delta FBQ2$ ) - $\Delta B$ < + 10mm
3-rail XXXXXX:	- 8mm < ( $\Delta FBX1 + \Delta FBX2 + \Delta FBX3 + \Delta FBX4 + \Delta FBX5 + \Delta FBX6$ ) - $\Delta B$ < + 14mm

## II.1.2.6 Installation tolerances

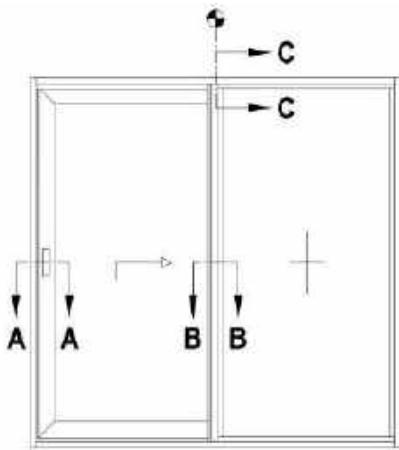

**A-A**

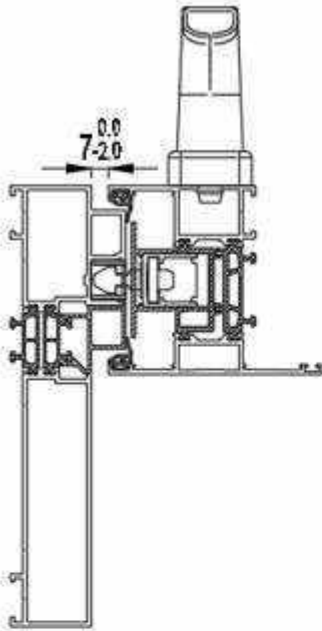

**B-B**

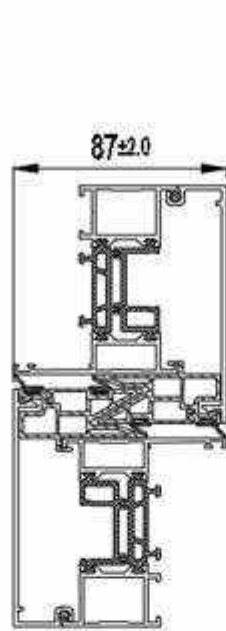

**C-C (\*)**

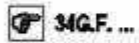
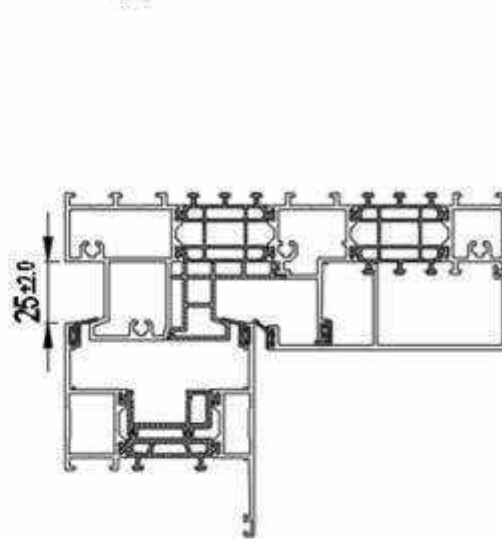

Adjustment of locking points

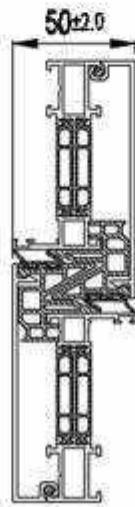

\* In every chicane position, the distance between the vent and frame should be  $25 \pm 2$  mm.

**II.2 INSTALLATION**

**II.2.1 Storage**

Unfinished or finished elements should always be stored in a dry, frost-free room.

**II.2.2 Fitting in the structural work**

The fixing to the structural work is done either directly through the profiles by means of for instance screws and plugs, or by means of fixing lugs.

- a. The fixings may not be applied less than 40 mm of the wall of the structural work.
- b. The anchoring may in no way influence the bearing power of the adjacent building parts.
- c. All anchoring, as far as they are not made of Aluminium or stainless steel, should be adequately corrosion-protected and may not attack the Aluminium themselves.
- d. When fitting the sliding elements, sufficient fixings are required:

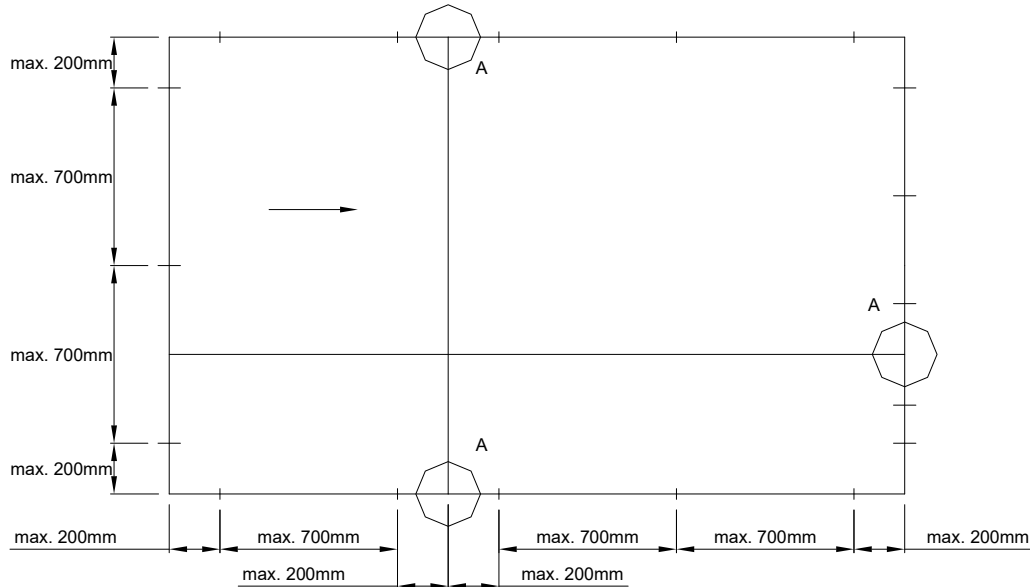

- e. At least two fixings should be applied on all sides; the maximum distance to the corner is 200 mm.
  - f. The distance between the fixings is maximum 700 mm.
- Where transom/mullions and outer frame profiles meet, the fixing must be applied maximum 200 mm from both sides of the transom/mullion (A).  
 In this way, expansion and shrinkage of the transom/mullion (because of fluctuations of temperature) are possible without any damage.  
 We recommend to position the fixings at the height of each locking point.

Remark: The anchoring should be applied in such a way that possible expansion / shrinkage of the sliding element is not obstructed.

When screws and plugs are used directly through the profiles, the chambers in the bottom outer frame may not be pierced to avoid water infiltration at the height of this fixing.

**II.2.3 Fitting of the accessories**

The choice of the fixing points, number of locking points, max. Weight of the sliding panel, max. Sizes of the sliding panel, panel profile used etc. depends on the instructions of the system supplier and the accessory producer.  
 Sliding and moving parts should be provided with neutral grease.

When fitting, please check whether all accessories can be operated easily and without getting stuck.

## II.3 GLAZING

Reynaers' systems are designed for EPDM gasket or neutral silicone glazing. In case of silicone glazing a backing rod should be applied to create a correct opening between the glass panel and the Aluminium frame. For easy and reliable fitting, durability and reglazing simplicity, we recommend using only Reynaers' gaskets – specially adapted for our profiles.

The following precautions should be taken when fitting the glazing:

- Cut the glazing gaskets slightly longer than is necessary to avoid openings in the corners at a later stage.
- Drainage holes should be drilled to avoid build-up moisture. This is also necessary in the case of silicone glazing (see drainage drawings).
- For placing of the glass panels a tolerance of at least 12 mm (6 mm per side) to the aluminium should be taken into account.
- The glass supports on the bottom of the glass panel should be sealed (see drawings below). Extra attention is needed for double and triple glazing

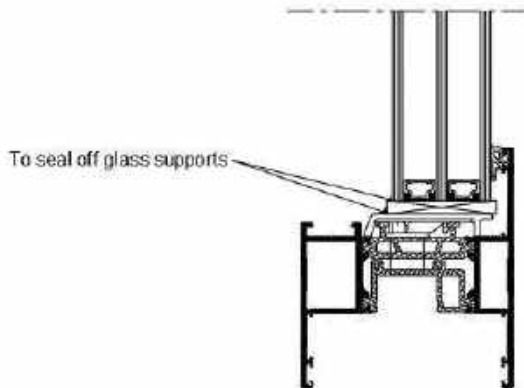

Fitting glass panels.

Glass panels should not come into contact with the Aluminium frame; always use glazing blocks and gaskets. Wedging prevents this contact and also ensures correct positioning of the glass in the frame, distributing the weight equally onto the rollers to avoid deformation.

In order to simplify fixing of the glazing we dispose of glass supports that can be used to level the bottom of the rebate. In this case it will be possible to apply rectangular glazing blocks.

For double and triple glazing there should be paid extra attention that the glass is supported over the whole panel thickness at all times and that the support blocks (C1) are strong enough to carry the whole glass panel weight.

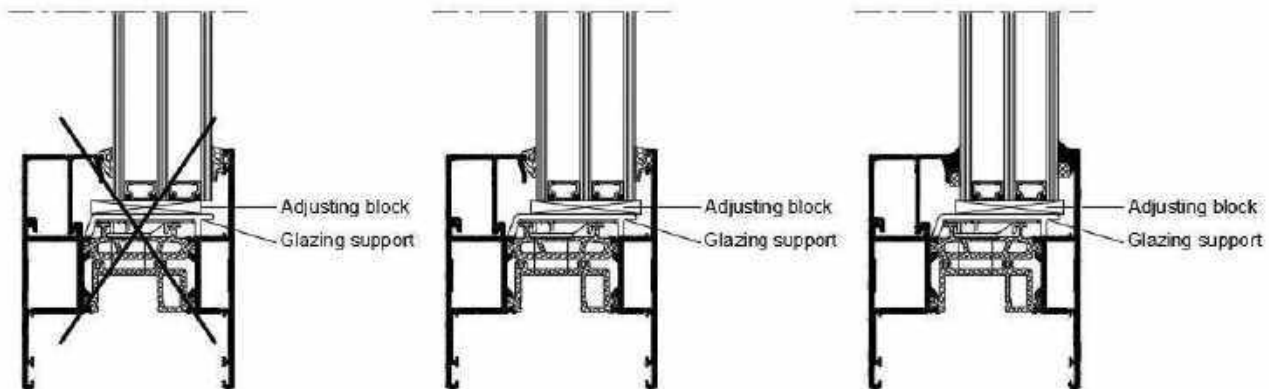

The number and position of the glass supports is defined by the STS 38.

An overview:

There are 2 types of glazing blocks:

support block



adjusting block

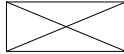

### C1: Support blocks

These blocks distribute the weight of the glass onto the sliding panel or the outer frame. Correct positioning is very important for the sliding panel to function correctly..

### C2: Adjusting blocks

These blocks guarantee the correct positioning of the glass between the rebates. They must be positioned without twisting or damaging the profile. Adjusting blocks also prevent the glass panels from moving.

The following sketches indicate the different glazing blocks in different types of sliding elements.

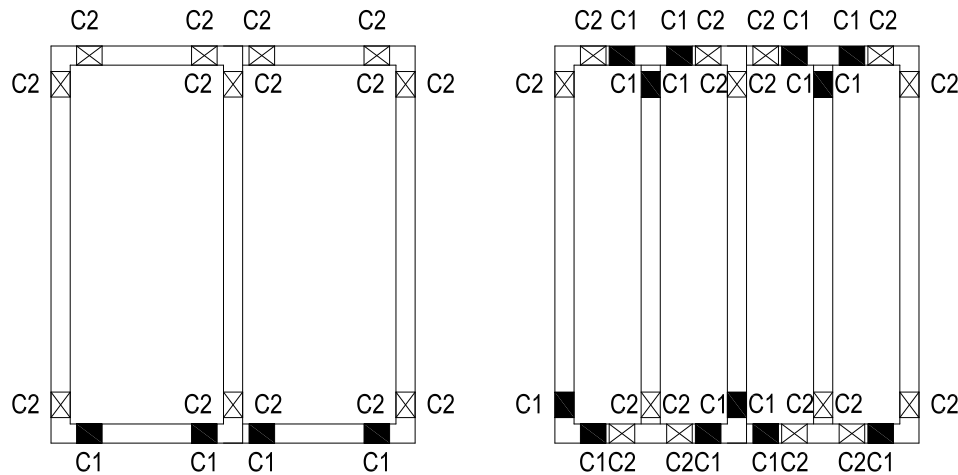

The glass weight of sliding panels should be distributed equally onto the rollers. The support blocks (C1) should consequently be fitted below at the height of the rollers.

The glass weight of fixed panels should be distributed onto the support piece of the fixed panel. The support blocks (C1) should consequently be fitted at the height of the support piece.

In fixed glazing monorail, supports are fitted in the corners of the bottom profile to avoid bending due to the weight of the glass (see sketch monorail).

For ease of fitting, we have special glass supports which can be used to equalize the rebate. The rectangular glazing blocks can be placed on these.

## II.4 USAGE

In locked position, the vent is standing on support pieces that are part of the wheels basic set. In this way the weight of the vent is not carried by the wheels. When the vent is in open position for a long time (more than 8h or more than 4h when +30°C), it's recommended to lower the vent on the support pieces, so no deformation of the wheels occurs.

If the weight of the vent has been on the wheels for a long time, temporary deformation of the wheels can occur. This deformation is the cause of a disturbing noise when the vent is opened and closed. This problem can be solved by opening and closing the vent a couple of times in quick succession.



# VERARBEITUNGSVORSCHRIFTEN

## I. ALLGEMEIN

Siehe Katalog "1. Allgemeine Information (099.C01\*.\*\*)

## II. VERARBEITUNGSVORSCHRIFTEN MASTERPATIO

### II.1 VERARBEITUNG

Um ein qualitativ hochwertiges Endprodukt zu erstellen, sollen bei der Verarbeitung folgende Punkte berücksichtigt werden:

#### II.1.1 Spanende Bearbeitungen

Mit spanenden Bearbeitungen sind alle mechanischen Bearbeitungen, wie Sägen, Fräsen, Bohren, Stanzen gemeint.

Bei allen mechanischen Bearbeitungen ist auf den Einsatz geeigneter Sägeblätter, Fräser und Bohrer zu achten, damit die Oberfläche nicht durch Grate oder abplatzende Beschichtung beschädigt wird.

Zur Profilbearbeitung geben wir folgende Hinweise:

Die spanabhebenden Werkzeuge müssen für den Werkstoff geeignet und ausreichend scharf sein.

Die Maschinendrehzahl muss auf den Werkstoff Aluminium abgestimmt sein.

Die Profilaufgaben müssen sauber und spanfrei sein.

Zur Verlängerung der Werkzeugstandzeiten können geeignete Gleitmittel, wie:

der Fettstift Reynalube (Art. Nr. 086.9191.UN);

das Reynaers-Schneidmittel (Art. Nr. 086.9175.--);

oder die von den Maschinenlieferanten vorgeschriebenen Kühl- und Schneidmittel verwendet werden.

Die geeignete Spanbacken sollen angewandt werden (Siehe Montagezeichnung „Spanbacken“)

Der Auflage- und Ablautisch soll frei von Spänen und Verunreinigung sein;

Diese Kühl- und Schneidmittel müssen chemisch neutrale Produkte sein, die die Oberfläche nicht angreifen.

Für die korrekte Funktion, Leistung und Ästhetik des Endprodukts ist es sehr wichtig, dass die Profile in engen Toleranzen gesägt werden. Falls strittig ist, was unter annehmbaren Abweichungen zu verstehen ist, können die Richtlinien von Instanzen wie Aluminium Center Belgium herangezogen werden.

#### Zuschnitt:

Der Auflage-/Säge-Tisch sollte eine glatte und ebene Auflagefläche bieten. Der dahinterliegende Anschlag sollte exakt im Winkel von 90° positioniert sein. Auf dem Maschinentisch sollen keine Verunreinigungen, wie Sägespäne oder Kleberreste vorhanden sein. Eine Fixierung der Profile erfolgt mittels Hand- oder pneumatischer Spannzylinder, welche von oben und von vorne auf das Profil wirken.

Ein Verdrehen der Profile während des Sägevorganges ist durch den Einsatz von Schneidzulagen zu verhindern.

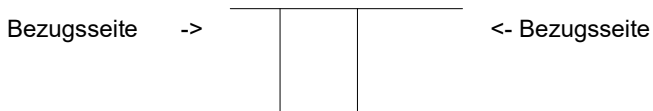

#### FALSCHE EINSpannung

FEHLER: Da der Hauptdruck der Spanvorrichtung auf die Falzseite des zu sägenden Profils einwirkt, verdreht sich das Werkstück.

FOLGE: Schiefer Sägeschnitt. Die Außenseite des Profils ist länger als die Innenseite.

ERGEBNIS: Beim Verpressen der Profile ist die Gehrung an der Innenseite dicht, steht aber an der Außenseite offen.

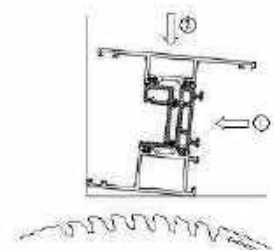

#### RICHTIGES SPANNEN

Der Hauptdruck der Spanvorrichtung wirkt ein auf die gesamte Fläche. Die Falzseite wird durch eine zweite Spanvorrichtung mit geringerer Kraft gehalten.

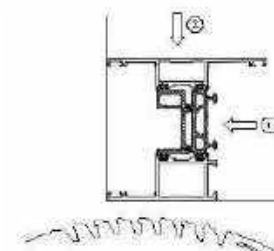

Durch diese korrekte Einspannung kann sich das Profil beim Sägevorgang nicht verdrehen.

Die Gehrung wird in der Eckverbindermaschine in der gleichen Art und Weise fixiert, so dass eine exakte Verbindung erreicht wird.

Anmerkung:

Es empfiehlt sich die Späne während des Sägevorganges abzusaugen.

Alle Sägeschnitte die eine Verbindung bilden sowie Eck- und T-Verbindungen müssen mit Reynaprotector geschützt worden.

Die andere Sägeschnitte (sowie Glasleiste, Klemmenleiste, ...) müssen mit Reynaers Anti-Corro (art.nr. 086.9606.--) geschützt werden, sowie Frässchnitte, Bohrlöcher, Stanzlöcher, ...

## II.1.2 Profilverbindungen und deren Verarbeitung

In den Reynaers-Katalogen wird nach 4 Verarbeitungsschritten unterschieden:

1. Eckverbindungen;
  - Presseckverbinder
  - Schraubeckverbinder
  - Stiften
2. T-Verbindungen;
3. Entwässerung und Vorbereitung für den Beschlageinbau;
4. Dichtungen.

### II.1.2.1 Eckverbindungen

Bevor die Eckverbindungen hergestellt werden, soll überprüft werden ob alle notwendigen verspanenden Bearbeitungen gut gemacht sind. Einige dieser Bearbeitungen können nicht später vorgenommen werden.

#### II.1.2.1.1 Presseckverbinder

Verfahrensweise:

- a. Korrekt zuschneiden
- b. Schutz der Schnittkanten und bearbeiteten Oberflächen durch:
  - Entgräten (falls erforderlich);
  - Schnittfläche und Profilkammern von Staub und Sägeresten säubern;
- c. Entfetten der Profile (Reynafinish 60 Art. Nr. 086.9210.-- oder Reynaers safety clean 086.9231.--);  
Korrosionsschutzprodukt Reynaprotector aufbringen auf Schnittflächen;
- d. In die Profilkammer Zweikomponentenkleber (Reynaseal duo Art. Nr. 084.9080.--) einbringen:
- e. Anbringen von Presseckwinkeln und Fülleckwinkeln;
- f. Verbinden und pressen;

Ausgetretener Kleber oder Dichtungsmittelreste müssen von den Sichtseiten entfernt werden (Reynafinish 60 Art. Nr. 086.9210.-- oder Reynaers safety clean 086.9231.--); Reynaers Anti-Corro (art.nr. 086.9606.--) aufbringen

Bemerkungen:

Für eine gute Wasserdichtheit des Blendrahmens soll zwischen der geraden Eckverbindung eine Abdichtung eingesetzt werden.

#### II.1.2.1.2 Schraubeckverbinder

Verfahrensweise:

- a. Korrekt zuschneiden
- b. Schutz der Schnittkanten und bearbeiteten Oberflächen durch:
  - Entgräten (falls erforderlich);
  - Schnittfläche und Profilkammern von Staub und Sägeresten säubern;
- c. Entfetten der Profile (Reynafinish 60 Art. Nr. 086.9210.-- oder Reynaers safety clean 086.9231.--);
- d. Korrosionsschutzprodukt Reynaprotector aufbringen auf Schnittflächen;
- e. In die Profilkammer Zweikomponentenkleber (Reynaseal duo Art. Nr. 084.9080.--) einbringen:
- f. Anbringen von Schraubeckwinkeln und Fülleckwinkeln;
- g. Verbinden und schrauben und stiften;
- h. Ausgetretener Kleber oder Dichtungsmittelreste müssen von den Sichtseiten entfernt werden (Reynafinish 60 Art. Nr. 086.9210.-- oder Reynaers safety clean 086.9231.--). Reynaers Anti-Corro (art.nr. 086.9606.--) aufbringen

Bemerkungen:

- Für eine gute Wasserdichtheit des Blendrahmens soll zwischen der geraden Eckverbindung eine Abdichtung eingesetzt werden.

#### II.1.2.1.3 Stiften

Verfahrensweise:

- a. Korrekt zuschneiden
- b. Anbringen von Stiftlöcher
- c. Schutz der Schnittkanten und bearbeiteten Oberflächen durch:  
-Entgräten (falls erforderlich);  
-Schnittfläche und Profilkammern von Staub und Sägeresten säubern;
- d. Entfetten der Profile (Reynafinish 60 Art. Nr. 086.9210.-- oder Reynaers safety clean 086.9231.--);
- e. Korrosionsschutzprodukt Reynaprotector aufbringen auf Schnittflächen;  
In die Profilkammer Zweikomponentenkleber (Reynaseal duo Art. Nr. 084.9080.--) einbringen:
- f. Anbringen von Schraubeckwinkeln und Fülleckwinkeln;
- g. Verbinden und stiften;
- h. Ausgetretener Kleber oder Dichtungsmittelreste müssen von den Sichtseiten entfernt werden (Reynafinish 60 Art. Nr. 086.9210.-- oder Reynaers safety clean 086.9231.--);
- i. Reynaers Anti-Corro (art.nr. 086.9606.--) aufbringen

**Bemerkungen:**

Für eine gute Wasserdichtheit des Blendrahmens soll zwischen der geraden Eckverbindung eine Abdichtung eingesetzt werden.

**II.1.2.2 T-Verbinder**
**Verfahrensweise:**

- a. Korrekt zuschneiden der Sprosse
- b. Anbringen von T-verbundglöcher
- c. Abfräsen der Falzhöhe der Sprosse
- d. Schutz der Schnittkanten und bearbeiteten Oberflächen durch:  
- Entgräten (falls erforderlich);  
- Schnittfläche und Profilkammern von Staub und Sägeresten säubern;
- e. Entfetten der Profile (Reynafinish Art. Nr. 086.9210.-- oder Reynaers safety clean 086.9231.--);
- f. Korrosionsschutzprodukt Reynaprotector aufbringen;
- g. Abdichtung: der Bereich im T-Stoss sowie der Bereich der Befestigungsmittel ist durch den Einsatz geeigneter Dichtungsmittel wasserdicht auszuführen;
- h. Abdichten der Zone unter der Sprosse auf dem Blendrahmen durch das Anbringen von Abdichtungselementen oder einem geeigneten Dichtungsmittel.  
Diese sollen wasserdicht ausgeführt werden. (monorail)
- i. Verbinden: nach dem Einbringen des T-verbinders, der Kleber und Dichtungsmittel, werden die Bauteile zusammengefügt, verstiftet bzw. Verschraubt.
- j. Nach dem Zusammenfügen müssen überschüssige Dichtungsmittelreste entfernt werden (Reynafinish Art. Nr. 086.9210.-- oder Reynaers safety clean 086.9231.--);

**II.1.2.3 Entwässerung und Bearbeitung für den Beschlageinbau**
**Verfahrensweise:**

- a. Die Aussparungen markieren.
- b. Korrekt stanzen, bohren oder fräsen.
- c. Schutz der Schnittkanten:  
- Entgräten (falls erforderlich);  
- Schnittfläche und Profilkammern von Staub und Sägeresten säubern;
- d. Entfetten der Profile (Reynafinish Art. Nr. 086.9210.-- oder Reynaers safety clean 086.9231.--);
- e. Korrosionsschutzprodukt Reynaprotector aufbringen;

Insbesondere ist auf folgendes zu achten:

Eventuell eingedrungenes Wasser muss problemlos und kontrolliert abgeleitet werden können

Es sind entsprechende Dampfdruckausgleichsbohrungen vorzunehmen.

Bei jedem Schiebeelement sind Entwässerungsbohrungen vorzunehmen. Diese sitzen max. 250 mm aus der Ecke für den Flügel und 150 mm für den Blendrahmen. Der Abstand zwischen 2 Entwässerungsöffnungen betragen max. 800 mm.

Für jede Glasoberfläche sollen mindestens 2 Entwässerungslöcher vorgesehen werden.

Die Entwässerungsöffnungen sind grundsätzlich am tiefsten Punkt der Profilkontur anzubringen.

Alle Schiebeelemente müssen im Solbankbereich bzw. an den horizontalen T-Profilen mit entsprechenden Ausnehmungen versehen werden.

Die Mindestoberfläche der Entwässerungsöffnung beträgt 50 mm<sup>2</sup> pro Öffnung im Flügel, wobei eine Bohrung von mind. 8 mm Durchmesser oder zwei Schlitze von 5 x 15 mm vorzusehen ist. Für den Blendrahmen beträgt die Mindestoberfläche pro Öffnung 150 mm<sup>2</sup>, wobei 3 Bohrungen von mind. 8 mm Durchmesser oder einen Schlitz von 8 x 34 mm vorzusehen ist.

Alle sichtbaren Entwässerungsöffnungen müssen mit systemabhängigen Kunststoff-Abdeckkappen versehen werden.

Bei jedem Schiebeelement sind grundsätzlich zwei Entlüftungsbohrungen vorzunehmen damit die Druckegaliserung rundum der Verglasung zu gewährleisten.

An der Flügeloberkante ist eine Druckausgleichsöffnung von mind. Ø5mm Größe vorzunehmen. (Seite G34.f. ...)  
Für feste Flügel muss die äußere Dichtung (180.9114.SY) über einen Abstand von 50 mm unterbrochen werden.  
Bemerkung: Spezifische Entwässerungsbohrungen sind gemäß der Seite 23.f. ... vorzunehmen.

#### **II.1.2.4 Dichtungen**

Alle angebotenen Dichtungsprofile bestehen aus EPDM mit einer hohen Alterungs- und Witterungsbeständigkeit. Die Verarbeitung der Dichtungen hat sorgfältig und entsprechend den folgenden Hinweisen zu erfolgen:

##### **a. Einbringen der Dichtungen/Verglasungsdichtungen**

Verfahrensweise:

1. Die Verglasungsdichtung wird je nach Erfordernis mit einer speziellen Schere (Art. Nr. 090.0121.UN) gerade oder auf Gehrung zugeschnitten. Je lfdm. Dichtung ist eine Überlänge von 10 mm hinzuzurechnen.
2. Das Einbringen der Dichtung erfolgt in die vorgesehenen Dichtungsaufnahmen. Beim Einbringen der Dichtungen wird der überlange Zuschnitt durch stauchen der Dichtungsprofile ausgeglichen. Durch die Anwendung des Silikonssprays (Art. Nr. 086.9551.--) wird das Einbringen der Dichtungen erleichtert.
3. Die Gehrungs- oder T-Stöße der Dichtungen sollen mit unserem Vulkanisierkleber (Art. Nr. 084.9108) verklebt werden an den Eckstücken.

##### **b. Bürstendichtungen**

Verfahrensweise:

1. Die Bürstendichtung wird je nach Erfordernis mit einer speziellen Schere (Art. Nr. 090.0121.UN) gerade oder auf Gehrung zugeschnitten.
2. Das Einbringen der Dichtung erfolgt in die vorgesehenen Dichtungsaufnahmen.
3. Je nach der Art Profilverbindung (gerade) wird die Bürstendichtung an den Enden mit Sekundenkleber (Reynaglu Art. Nr. 084.9107.--) verklebt. Dank dieser Verklebung wird das Ausrutschen der Bürstendichtung vermieden.

##### **c. Applying a closer at the bottom and the top of the meeting section**

Für eine gute Wasser- und Winddichtheit soll unten und oben auf dem Wechselprofil eine zusätzliche Abdichtung montiert werden.

**II.1.2.5 Fertigungstoleranzen**

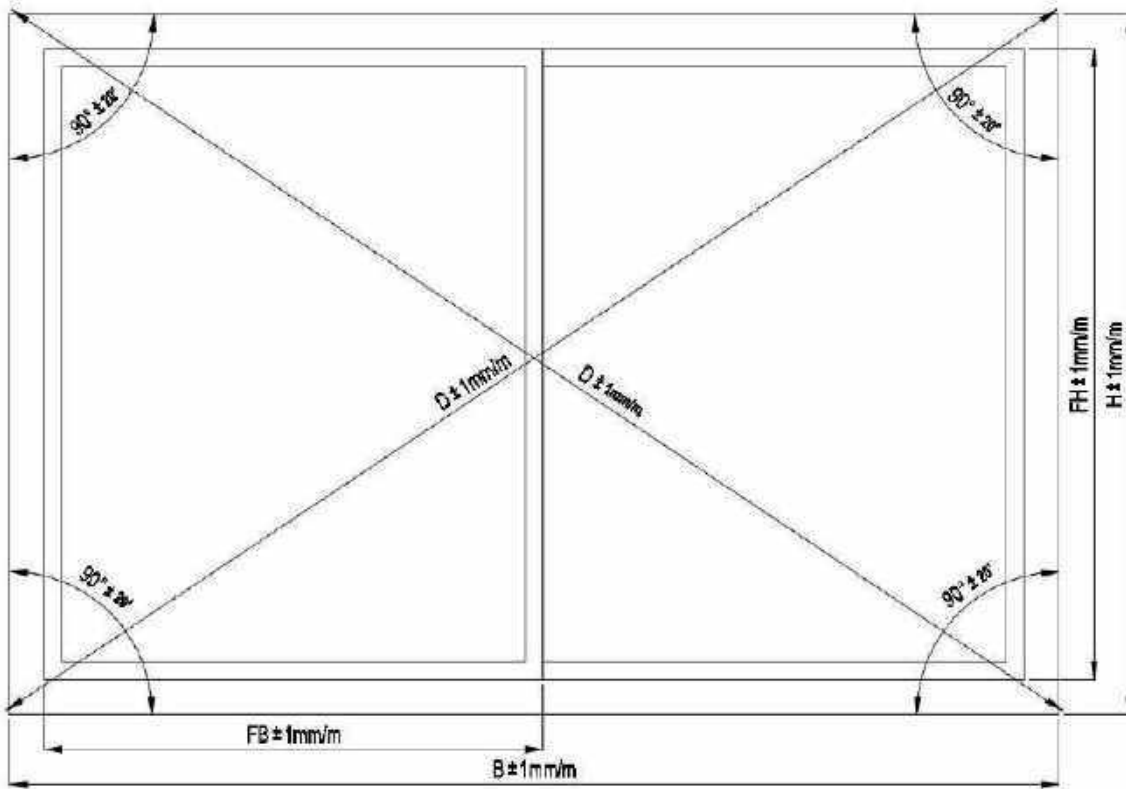

- 1mm < ΔH – ΔFH < + 1mm

- Monorail XQ: - 2mm < (ΔFBX + ΔFBQ) – ΔB < + 4mm
- Monorail XQX: - 4mm < (ΔFBX1 + ΔFBQ + ΔFBX2) – ΔB < + 8mm
- Monorail QXQ: - 2mm < (ΔFBQ1 + ΔFBX + ΔFBQ2) – ΔB < + 4mm
- Monorail QXXQ: - 4mm < (ΔFBQ1 + ΔFBX1 + ΔFBX2 + ΔFBQ2) – ΔB < + 6mm
  
- 2-rail XQ: - 2mm < (ΔFBX + ΔFBQ) – ΔB < + 4mm
- 2-rail XX: - 2mm < (ΔFBX1 + ΔFBX2) – ΔB < + 6mm
- 2-rail XQX: - 4mm < (ΔFBX1 + ΔFBQ + ΔFBX2) – ΔB < + 8mm
- 2-rail QXQ: - 2mm < (ΔFBQ1 + ΔFBX + ΔFBQ2) – ΔB < + 4mm
- 2-rail QXXQ: - 4mm < (ΔFBQ1 + ΔFBX1 + ΔFBX2 + ΔFBQ2) – ΔB < + 6mm
- 2-rail XXXX: - 4mm < (ΔFBX1 + ΔFBX2 + ΔFBX3 + ΔFBX4) – ΔB < + 10mm
  
- 3-rail XXQ: - 4mm < (ΔFBX1 + ΔFBX2 + ΔFBQ) – ΔB < + 6mm
- 3-rail XXX: - 4mm < (ΔFBX1 + ΔFBX2 + ΔFBX3) – ΔB < + 8mm
- 3-rail QXXXXQ: - 8mm < (ΔFBQ1 + ΔFBX1 + ΔFBX2 + ΔFBX3 + ΔFBX4 + ΔFBQ2) – ΔB < + 10mm
- 3-rail XXXXXX: - 8mm < (ΔFBX1 + ΔFBX2 + ΔFBX3 + ΔFBX4 + ΔFBX5 + ΔFBX6) – ΔB < + 14mm

## II.1.2.6 Einbautoleranzen

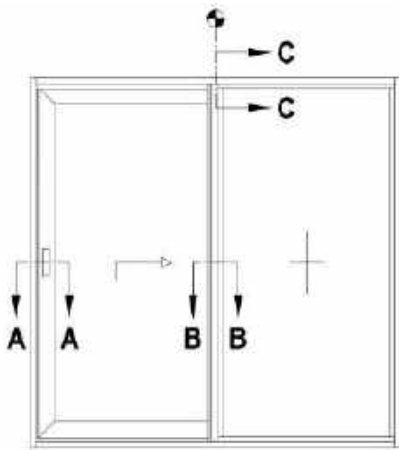

**A-A**

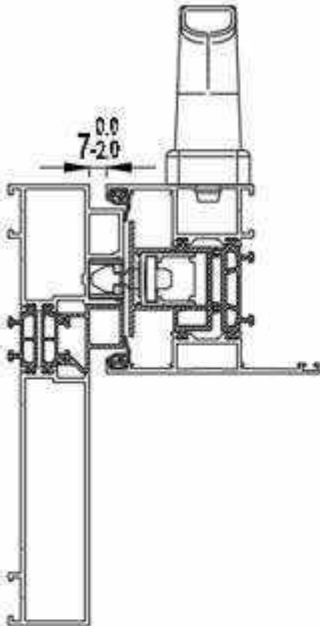

**B-B**

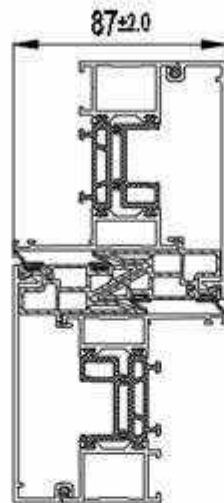

**C-C (\*)**

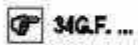
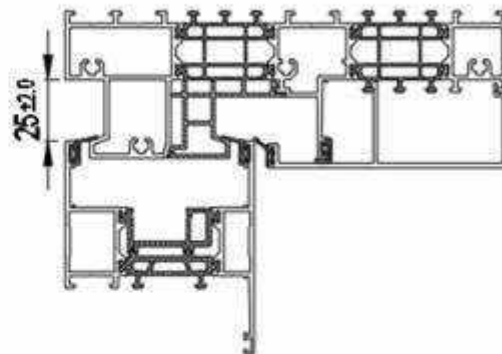

Einstellen der schliesspunkte

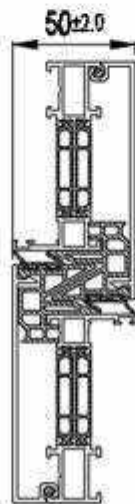

\* In jeder wechselfprofilposition sollte der Abstand zwischen fluegel und rahmen  $25\pm 2$ mm betragen.

## II.2 MONTAGE

### II.2.1 Lagerung

Die Lagerung nicht verarbeiteter oder verarbeiteter Elemente muss in jedem Fall in einem trockenen, frostfreien Raum erfolgen.

### II.2.2 Befestigung am Baukörper

Die Befestigung am Baukörper erfolgt durch systemabhängige Befestigungsanker, Rohrrahmendübel oder andere Befestigungsteile.

- Beim Einsatz von Schrauben und Dübeln ist zu gewährleisten, dass die Mindestabstände gemäß den Verarbeitungsrichtlinien der Befestigungshersteller eingehalten werden.
- Die Verankerung ist so zu wählen, dass die auf das Schiebelement einwirkenden Lasten sicher an den Baukörper abgeleitet werden.
- Alle zum Einsatz kommenden Verankerungen sollen aus Aluminium oder Edelstahl bzw. korrosionsschutz sein, damit die Aluminiumprofile nicht angegriffen werden.
- Die Anzahl der Befestigungspunkte ist wie folgt festzulegen:

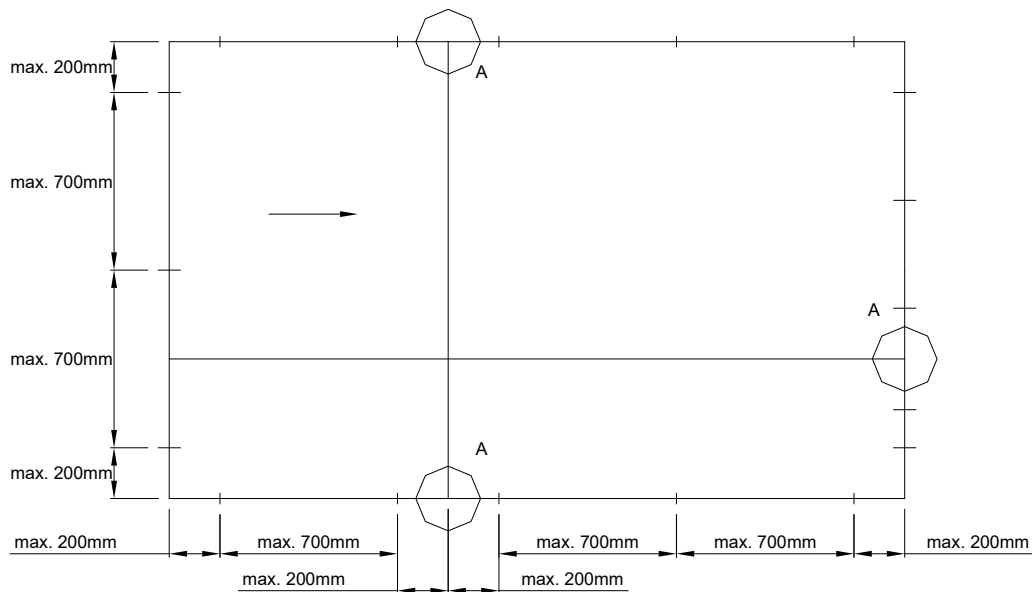

- Je Rahmenseite müssen mind. zwei Befestigungen eingebracht werden.
- Der max. Abstand zur Rahmenecke darf 200 mm nicht verbreiten.  
Der max. Abstand der Befestigungspunkte untereinander darf 700 mm nicht verbreiten.  
Im Bereich von Pfosten- und Riegelanschluss sind die Befestigungspunkte ebenfalls 200 mm aus der Ecke vorzunehmen. Es wird empfohlen, die Befestigungspunkte in den Bereich der Eck- und Scherenlager sowie in den Bereich der Verriegelungspunkte (des Schlosses) zu legen.

Anmerkung: Die Befestigungen sollen so angebracht werden, dass ein eventuelles Arbeiten der Aluminiumelemente aufgenommen werden kann. Beim Einsatz von Schrauben und Dübeln durch die Profile dürfen die Kammern im Unterblendrahmen nicht durchbohrt werden um Wassereindringung im Bereich dieser Befestigung zu vermeiden.

### II.2.3 Einbau der Beschläge

Die Auswahl der Beschläge hat entsprechend den Vorgaben des Systemlieferanten bzw. des Herstellers der Beschläge zu erfolgen. Die hier angegebenen Werte bzgl. der max. Flügelabmessungen, des max. Flügelgewichtes, der Anzahl der Verschlusspunkte sind einzuhalten. Bewegliche Teile sind, entsprechend den Angaben des Beschlagherstellers, mit säurefreiem Fett zu versehen. Eine Funktionsprüfung der Beschläge ist nach erfolgter Fertigung und Montage unerlässlich.

## II.3 VERGLASUNG

Alle Reynaers-Systeme können mit speziellen EPDM Dichtprofilen als Trockenverglasung oder als Nassverglasung (Silikon) auf Vorlegeband mit Vorprimern verarbeitet werden.

Wir empfehlen den Einsatz unserer EPDM Dichtprofile, da diese leicht zu verarbeiten sind und den Austausch beschädigter Verglasungen oder Paneele erleichtern.

Bei der Verglasung müssen folgende Punkte berücksichtigt werden:

- Verglasungen oder Paneele sollten so bemessen sein, dass mind. eine umlaufende Falzluft von 4 mm vorhanden ist.
- Für alle Reynaers-Systeme stehen sogenannte Klotzbrücken zur Verfügung.
- Diese überbrücken den Falzgrund, so dass die Luft um die Scheibe zirkulieren kann, und bieten durch ihre glatte Oberfläche eine saubere Auflage für die einzubringenden Verglasungsklotze.
- Die Verglasungsklotze sollten mind. 2 mm breiter als die Gesamtscheibenstärke sein.

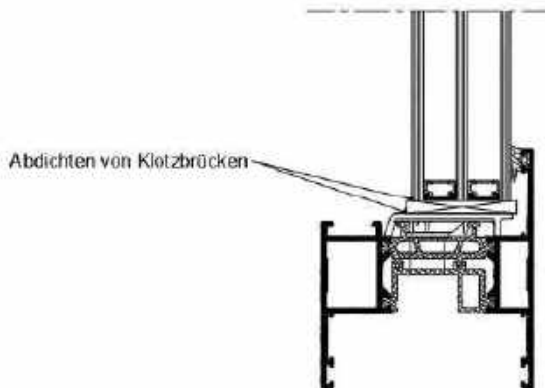

Damit die Befestigung erleichtert wird, kommen Glasauflageprofile (Klotzbrücken) zur Ausführung, um den Falzbereich auszugleichen. Rechteckige Verglasungsklotze können jetzt eingebracht werden.

Bei Doppel- oder Dreifachverglasung soll darauf geachtet werden, dass die Glasdicke vollständig unterstützt wird und, dass die Stützklotze genügend stark sind damit das vollständige Glassgewicht zu tragen.

Die Anzahl und die Position der Klotzbrücken bzw. Verglasungsklotze wird durch Verarbeitungsvorschriften der Isolierglasindustrie und technische Richtlinien des Glaserhandwerks vorgegeben.

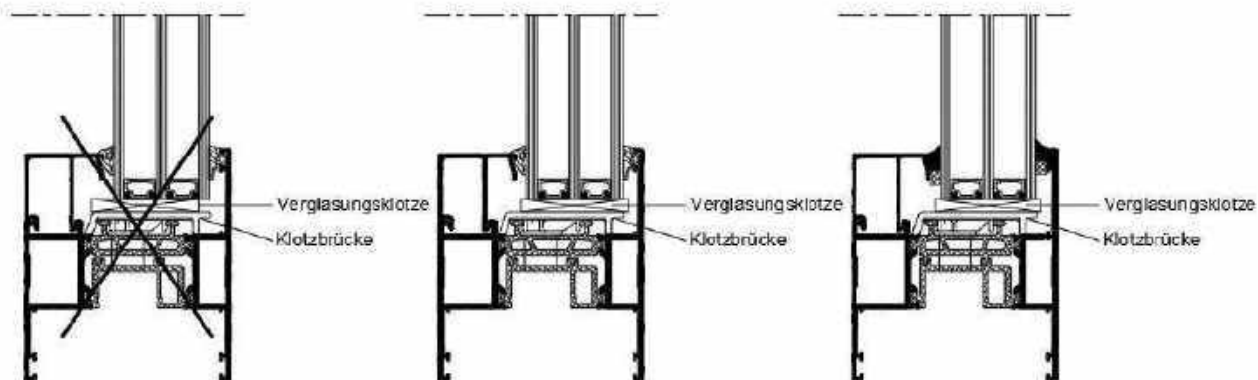

## Übersicht:

Bei der Verglasung unterscheiden wir nach Trag- und Distanzklötzen. Die Verglasungsklötze sind gegen Verrutschen zu sichern:

Tragklötze



Distanzklötze



### C1: Die Tragklötze

übertragen das Scheibengewicht auf den Rahmen bzw. Flügel und stellen die Gangbarkeit der beweglichen Flügel sicher.

### C2: Die Distanzklötze

stellen den Abstand zwischen Rahmen und Verglasung sicher. Je nach Flügelöffnungsart können diese auch eine tragende Funktion übernehmen.

Die Anzahl und Position der Klotzbrücken bzw. Verglasungsklötze wird durch Verarbeitungsvorschriften der Isolierglasindustrie und den Technischen Richtlinien des Glaserhandwerks vorgegeben.

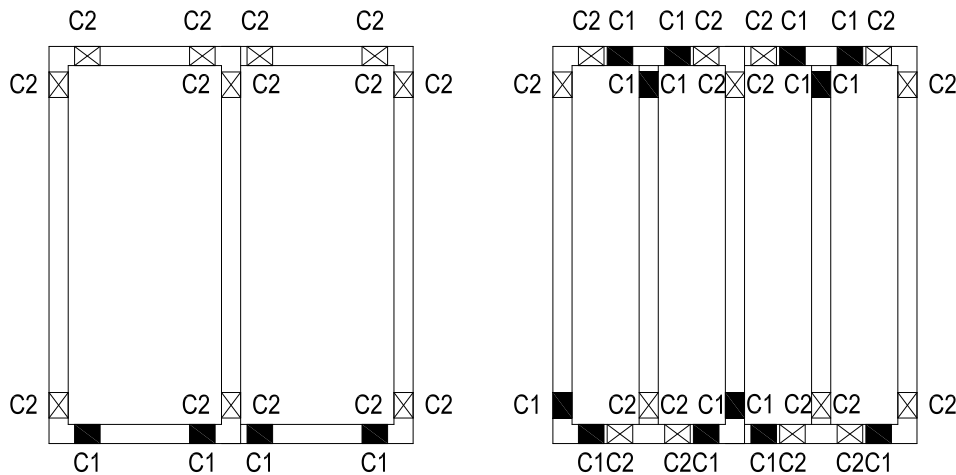

Nachstehend eine Übersicht über den Sitz und die Anzahl der Verglasungsklötze in den verschiedenen Typen von Schiebeelementen.

Bei schiebenden Flügeln wird das Scheibengewicht auf die Laufwagen übertragen. Die Verglasungsklötze (C1) müssen unten also im Bereich der Laufwagen montiert werden.

Bei festen Flügeln wird das Scheibengewicht auf die Stütze des festen Flügels übertragen. Die Verglasungsklötze (C1) müssen also im Bereich dieser Stütze montiert werden.

## II.4 VERWENDUNG

In der verriegelten Position ruht der Flügel auf Tragstücken, die Teil des Rad-Basissatzes sind. Dadurch wird dafür gesorgt, dass das Gewicht des Flügels nicht von den Rädern getragen wird. Wenn der Flügel längere Zeit geöffnet wird (mehr als 8S oder mehr als 4S bei +30°C), empfiehlt es sich, den Flügel auf die Tragstücke absinken zu lassen, damit es nicht zu einer Verformung der Räder kommt.

Wenn das Gewicht des Flügels längere Zeit auf den Rädern gelastet hat, kann es zu einer vorübergehenden Verformung der Räder kommen. Diese Verformung verursacht ein störendes Geräusch beim Öffnen und Schließen des Flügels. Dieses Problem kann durch mehrmaliges Öffnen und Schließen des Flügels in schneller Folge gelöst werden.



# BIMETAAL EFFECT OP SCHUIFDEUREN

## I. Omschrijving van bimetaal effect

Het bimetaal effect zal zich voordoen bij schuifdeuren als er een temperatuur verschil is tussen de binnen- en buitenhalschaal van een thermisch geïsoleerd profiel. Dit is het geval voor plaatsen met een warm klimaat en voor plaatsen met een extreem koud klimaat. Het effect veroorzaakt door zonnestraling is veel doorslaggevend dan het waargenomen effect bij koude omstandigheden (temperaturen beneden de  $-20^{\circ}\text{C}$ ).

Voor schuifdeuren zijn twee types van het bimetaal effect gekend.

- Opwarming van de holte: De profielen van de wisselprofiel sectie buigen naar elkaar als de vleugel geopend is.
- Direct zonlicht: Buiging van de profielen in één richting

### I.1 Opwarming van de holte

Als een schuifdeur geopend is, is er een holte tussen de twee glaspanelen. Als de zon deze holte opwarmt en de profielen een lichte kleur hebben (groep 7-14 zie I.2.1) zullen de wisselprofielen naar elkaar toe buigen. Als de deur gesloten wordt kunnen de PVC wisselprofielen elkaar beschadigen.

### I.2 Direct zonlicht

Het vleugelprofiel aan de slotzijde (in open en gesloten positie) en de profielen van de wisselsectie (gesloten positie) zullen tijdelijk buigen als deze worden opgewarmd door direct zonlicht. De kleur van de profielen, de locatie en de oriëntatie van de schuifdeur hebben hierop een significante invloed. Het zonlicht is meer direct in oost en west georiënteerde gevels, ten gevolge van de verticale positie van de profielen en de lage stand van de zon in deze windrichtingen.

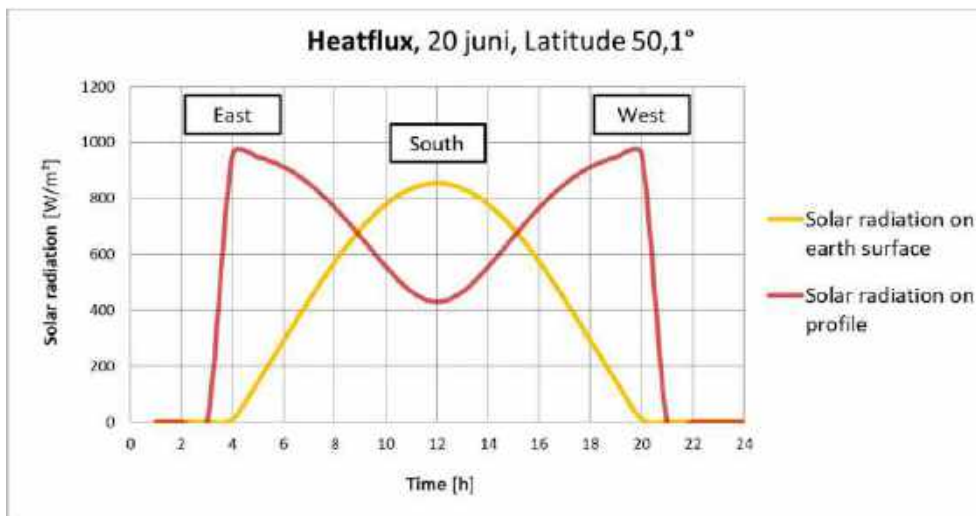

Figure 1: Zonlichtstraling op zomerdag

De werkelijke straling op de profielen zal beïnvloed worden door de situatie (b.v. omringende gebouwen, zonneweringen, bomen, wolken, atmosferische omstandigheden, enz.) die voor extra schaduw kan zorgen en moet geëvalueerd worden in functie van het project.

### I.2.1 Stralingsopname: kleur afhankelijk

De kleur van het profiel beïnvloedt de temperatuur van de buitenhelftschaal. De kleur bepaalt de warmteopname. Hoe donkerder de kleur (groep 1), hoe kritieker. De verschillende kleuren zijn gegroepeerd gebaseerd op hun gedrag. De volgende kleurgroepen (RAL) zullen gelijkaardig gedrag vertonen.

1	5004 8022 9005	<i>Waarbij RAL 9005 – Jet Zwart</i>
2	3004 3005 3007 4007 5003 5008 5011 5013 5020 5022 6005 6007 6008 6009 6012 6022 7021 8014 8016 8017 8019 9004 9011 9017	
3	3003 3009 3011 5000 5001 5002 5010 6004 6006 6014 6015 6020 7016 7022 7024 7026 8011 8012 8015 8028	
4	3000 3001 3002 3013 3027 4002 4006 5005 5009 5017 5019 6002 6003 6016 6026 6028 7009 7010 7011 7013 7015 7043 8002 8003 8007 8008 8024	
5	2002 3016 3020 3031 4008 5007 5021 5023 6000 6001 6010 6025 6029 7006 7008 7012 7031 7039 8004 8025	
6	2001 3017 3018 4001 4005 4010 5014 5015 6011 6013 6017 6024 6032 7003 7005 8000 8001 8023	
7	1027 2004 2009 2010 2012 3022 4003 5012 5018 6018 6033 7000 7002 7023 7033 7034 7037 7046	
8	1005 1011 1019 1020 1024 2000 2008 2011 3012 3014 4009 5024 6021 7001 7030 7036 7042 7045	
9	1006 1007 2003 6034 7004 7040	
10	1001 1002 1012 1028 1033 1034 3015 6027 7032 7038 7044	
11	1000 1003 1017 1021 1023 6019 7035	
12	1014 1018 7047 9018	
13	1013 1015 1016	
14	9003 9010 9016	<i>Waarbij RAL 9016 – Verkeers Wit</i>

Tabel 1: Kleurgroepen

## II. Verklaring van de grafieken

Het bimetaaleffect wordt beïnvloed door de **zonnestraling** op het profieloppervlak, de **temperatuur van de buitenlucht** en de **oriëntatie** van de schuifdeur.

Hieronder vindt u grafieken voor oost/west en zuid georiënteerde gevels, telkens voor twee verschillende buitentemperaturen. Selecteer de situatie die het nauwst bij uw locatie aansluit.

### SELECTIESTAPPEN:

- Selecteer de isolatievariant (standaard of HI)
- Grafieken voor de profielen met ingebouwd slot, gebaseerd op oriëntatie en temperatuur
- Selecteer de grafiek die het best overeenstemt met de gemiddelde buitentemperatuur tijdens de zomer op de locatie in kwestie
- Selecteer de oriëntatie van de gevel
- Zoek de maatregelen op die genomen moeten worden om de tijdelijke vervorming als gevolg van het bimetaaleffect tot een minimum te beperken.
- Grafieken voor op elkaar aansluitende profielen (één grafiek is van toepassing voor alle oriëntaties en voor gemiddelde zomertemperaturen (buiten) tot  $T_{ext}=35\text{ °C}$ )
- Raadpleeg het hoofdstuk 'Oplossingen' voor details over de vereiste afmetingen.

Voor een gemiddelde lucht temperatuur tot  $25\text{ °C}$  tijdens de zomermaanden, kiest u de grafieken met  $T_{ext} = 25\text{ °C}$ . Voor een gemiddelde luchttemperatuur tussen  $26\text{--}35\text{ °C}$  in de zomer, selecteert u de grafieken met  $T_{ext} = 35\text{ °C}$ . Voor hogere buitentemperaturen is een voor het project specifieke berekening vereist.

## III. Oplossingen

### III.1 Slot zijde

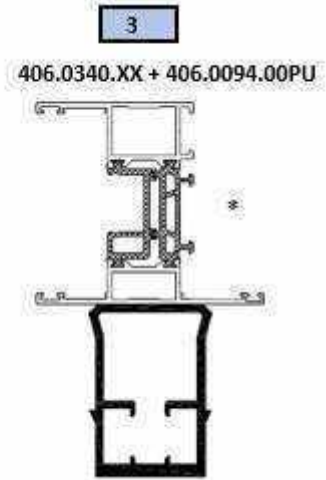
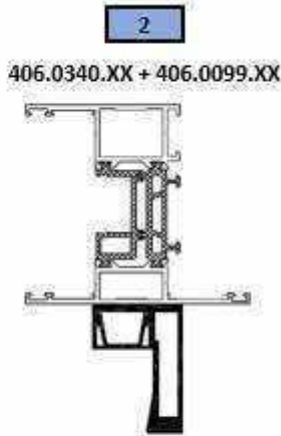

**-**  
 Directe zonnestraling op de profielen  
 is niet raadzaam.\*\*

Reynaers heeft zonweringsystemen in  
 zijn aanbod (BS 30, BS 100).



### III.2 Wisselprofiel sectie

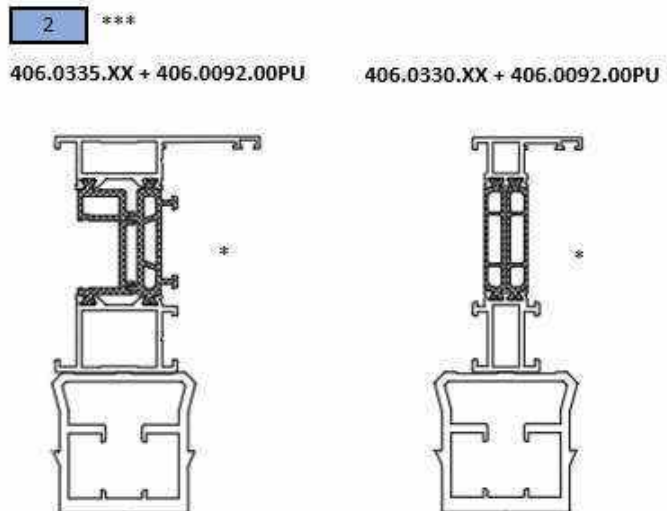
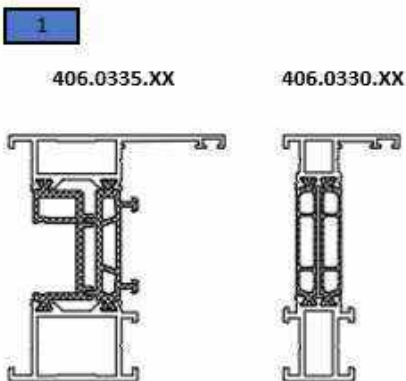

\* Elke versterking die de Ix waarde van deze combinatie bereikt kan gebruikt worden.

\*\* Voor specifieke projecten kan een berekening aangevraagd worden om de functionaliteit van het element te evalueren.

\*\*\* Voor de wisselprofiel sectie moet de versterking op het profiel aan de buitenzijde geplaatst worden.

Standaard isolatie variant – Slot zijde – Gemiddelde buitentemperatuur in de zomer = 25°C

**Zuid oriëntatie**

		Vleugel hoogte (mm)																
		2000	2100	2200	2300	2400	2500	2600	2700	2800	2900	3000	3100	3200	3300	3400	3500	3600
Kleur	1	1	1	1	1	1	1	1	1	2	2	2	2	2	3	3	3	3
	2	1	1	1	1	1	1	1	1	1	2	2	2	2	2	3	3	3
	3	1	1	1	1	1	1	1	1	1	1	2	2	2	2	2	3	3
	4	1	1	1	1	1	1	1	1	1	1	2	2	2	2	2	3	3
	5	1	1	1	1	1	1	1	1	1	1	1	2	2	2	2	2	3
	6	1	1	1	1	1	1	1	1	1	1	1	1	2	2	2	2	2
	7	1	1	1	1	1	1	1	1	1	1	1	1	1	1	2	2	2
	8	1	1	1	1	1	1	1	1	1	1	1	1	1	1	1	2	2
	9	1	1	1	1	1	1	1	1	1	1	1	1	1	1	1	2	2
	10	1	1	1	1	1	1	1	1	1	1	1	1	1	1	1	1	1
	11	1	1	1	1	1	1	1	1	1	1	1	1	1	1	1	1	1
	12	1	1	1	1	1	1	1	1	1	1	1	1	1	1	1	1	1
	13	1	1	1	1	1	1	1	1	1	1	1	1	1	1	1	1	1
	14	1	1	1	1	1	1	1	1	1	1	1	1	1	1	1	1	1

**Oost/West oriëntatie**

		Vleugel hoogte (mm)																
		2000	2100	2200	2300	2400	2500	2600	2700	2800	2900	3000	3100	3200	3300	3400	3500	3600
Kleur	1	1	1	1	1	1	1	2	2	2	2	3	3	3	3	3	3	3
	2	1	1	1	1	1	1	1	2	2	2	2	3	3	3	3	3	3
	3	1	1	1	1	1	1	1	2	2	2	2	2	3	3	3	3	3
	4	1	1	1	1	1	1	1	1	2	2	2	2	2	3	3	3	3
	5	1	1	1	1	1	1	1	1	1	2	2	2	2	2	3	3	3
	6	1	1	1	1	1	1	1	1	1	1	2	2	2	2	2	3	3
	7	1	1	1	1	1	1	1	1	1	1	1	2	2	2	2	2	3
	8	1	1	1	1	1	1	1	1	1	1	1	1	2	2	2	2	2
	9	1	1	1	1	1	1	1	1	1	1	1	1	1	1	2	2	2
	10	1	1	1	1	1	1	1	1	1	1	1	1	1	1	1	2	2
	11	1	1	1	1	1	1	1	1	1	1	1	1	1	1	1	1	1
	12	1	1	1	1	1	1	1	1	1	1	1	1	1	1	1	1	1
	13	1	1	1	1	1	1	1	1	1	1	1	1	1	1	1	1	1
	14	1	1	1	1	1	1	1	1	1	1	1	1	1	1	1	1	1

- 1 406.0340
- 2 406.0340 + 406.0099
- 3 406.0340 + 406.0094

- Het wordt aangeraden directe zonnestraling te vermijden

Raadpleeg het hoofdstuk ‘Oplossingen’ om alle details van elke afmeting te zien.

De verbuiging van het profiel is te wijten aan de snelle opwarming door de zonnestraling en is tijdelijk. Het fenomeen komt voor op specifieke momenten van specifieke dagen in het jaar. Bij het opstellen van de grafieken werd rekening gehouden met de maximale mogelijke verbuiging die kan voorkomen wanneer het profiel aan de maximale zonnestraling blootgesteld wordt, en met de specifieke buitentemperatuur. Een voor het project specifieke berekening kan vereist zijn om de functionaliteit van het element te beoordelen.

Standaard isolatie variant – Slot zijde – Gemiddelde buitentemperatuur in de zomer = 35°C

**Zuid oriëntatie**

		Vleugel hoogte (mm)																
		2000	2100	2200	2300	2400	2500	2600	2700	2800	2900	3000	3100	3200	3300	3400	3500	3600
Kleur	1	1	1	1	1	1	1	2	2	2	2	2	3	3	3	3	-	-
	2	1	1	1	1	1	1	1	2	2	2	2	3	3	3	3	3	-
	3	1	1	1	1	1	1	1	1	2	2	2	2	3	3	3	3	-
	4	1	1	1	1	1	1	1	1	2	2	2	2	3	3	3	3	-
	5	1	1	1	1	1	1	1	1	1	2	2	2	2	3	3	3	3
	6	1	1	1	1	1	1	1	1	1	1	2	2	2	2	3	3	3
	7	1	1	1	1	1	1	1	1	1	1	1	2	2	2	2	3	3
	8	1	1	1	1	1	1	1	1	1	1	1	1	2	2	2	2	2
	9	1	1	1	1	1	1	1	1	1	1	1	1	2	2	2	2	2
	10	1	1	1	1	1	1	1	1	1	1	1	1	1	1	2	2	2
	11	1	1	1	1	1	1	1	1	1	1	1	1	1	1	2	2	2
	12	1	1	1	1	1	1	1	1	1	1	1	1	1	1	1	1	2
	13	1	1	1	1	1	1	1	1	1	1	1	1	1	1	1	1	1
	14	1	1	1	1	1	1	1	1	1	1	1	1	1	1	1	1	1

**Oost/West oriëntatie**

		Vleugel hoogte (mm)																
		2000	2100	2200	2300	2400	2500	2600	2700	2800	2900	3000	3100	3200	3300	3400	3500	3600
Kleur	1	1	1	1	1	1	2	2	2	2	3	3	3	3	-	-	-	-
	2	1	1	1	1	1	2	2	2	2	3	3	3	3	-	-	-	-
	3	1	1	1	1	1	1	2	2	2	2	3	3	3	3	-	-	-
	4	1	1	1	1	1	1	2	2	2	2	2	3	3	3	3	-	-
	5	1	1	1	1	1	1	1	2	2	2	2	3	3	3	3	3	-
	6	1	1	1	1	1	1	1	1	2	2	2	2	3	3	3	3	-
	7	1	1	1	1	1	1	1	1	1	2	2	2	2	3	3	3	3
	8	1	1	1	1	1	1	1	1	1	1	2	2	2	2	3	3	3
	9	1	1	1	1	1	1	1	1	1	1	1	2	2	2	2	3	3
	10	1	1	1	1	1	1	1	1	1	1	1	1	2	2	2	2	2
	11	1	1	1	1	1	1	1	1	1	1	1	1	1	2	2	2	2
	12	1	1	1	1	1	1	1	1	1	1	1	1	1	1	2	2	2
	13	1	1	1	1	1	1	1	1	1	1	1	1	1	1	1	1	2
	14	1	1	1	1	1	1	1	1	1	1	1	1	1	1	1	1	1

- 1 406.0340
- 2 406.0340 + 406.0099
- 3 406.0340 + 406.0094

- Het wordt aangeraden directe zonnestraling te vermijden

Raadpleeg het hoofdstuk ‘Oplossingen’ om alle details van elke afmeting te zien.

De verbuiging van het profiel is te wijten aan de snelle opwarming door de zonnestraling en is tijdelijk. Het fenomeen komt voor op specifieke momenten van specifieke dagen in het jaar. Bij het opstellen van de grafieken werd rekening gehouden met de maximale mogelijke verbuiging die kan voorkomen wanneer het profiel aan de maximale zonnestraling blootgesteld wordt, en met de specifieke buitentemperatuur. Een voor het project specifieke berekening kan vereist zijn om de functionaliteit van het element te beoordelen.

HI isolatie variant – Slot zijde – Gemiddelde buitentemperatuur in de zomer = 25°C

Zuid oriëntatie

		Vleugel hoogte (mm)																	
		2000	2100	2200	2300	2400	2500	2600	2700	2800	2900	3000	3100	3200	3300	3400	3500	3600	
Kleur	1	1	1	1	1	1	1	1	2	2	2	2	3	3	3	3	3	3	
	2	1	1	1	1	1	1	1	1	2	2	2	2	3	3	3	3	3	
	3	1	1	1	1	1	1	1	1	1	2	2	2	2	3	3	3	3	
	4	1	1	1	1	1	1	1	1	1	1	2	2	2	2	3	3	3	
	5	1	1	1	1	1	1	1	1	1	1	1	2	2	2	2	2	3	
	6	1	1	1	1	1	1	1	1	1	1	1	1	2	2	2	2	2	3
	7	1	1	1	1	1	1	1	1	1	1	1	1	1	2	2	2	2	2
	8	1	1	1	1	1	1	1	1	1	1	1	1	1	1	1	2	2	2
	9	1	1	1	1	1	1	1	1	1	1	1	1	1	1	1	2	2	2
	10	1	1	1	1	1	1	1	1	1	1	1	1	1	1	1	1	1	1
	11	1	1	1	1	1	1	1	1	1	1	1	1	1	1	1	1	1	1
	12	1	1	1	1	1	1	1	1	1	1	1	1	1	1	1	1	1	1
	13	1	1	1	1	1	1	1	1	1	1	1	1	1	1	1	1	1	1
	14	1	1	1	1	1	1	1	1	1	1	1	1	1	1	1	1	1	1

Oost/West oriëntatie

		Vleugel hoogte (mm)																	
		2000	2100	2200	2300	2400	2500	2600	2700	2800	2900	3000	3100	3200	3300	3400	3500	3600	
Kleur	1	1	1	1	1	1	2	2	2	2	3	3	3	3	3	3	3	3	
	2	1	1	1	1	1	2	2	2	2	2	3	3	3	3	3	3	3	
	3	1	1	1	1	1	1	2	2	2	2	3	3	3	3	3	3	3	
	4	1	1	1	1	1	1	1	2	2	2	2	3	3	3	3	3	3	
	5	1	1	1	1	1	1	1	1	2	2	2	2	3	3	3	3	3	
	6	1	1	1	1	1	1	1	1	1	2	2	2	2	3	3	3	3	
	7	1	1	1	1	1	1	1	1	1	1	2	2	2	2	2	3	3	
	8	1	1	1	1	1	1	1	1	1	1	1	2	2	2	2	2	3	
	9	1	1	1	1	1	1	1	1	1	1	1	1	2	2	2	2	2	
	10	1	1	1	1	1	1	1	1	1	1	1	1	1	1	2	2	2	
	11	1	1	1	1	1	1	1	1	1	1	1	1	1	1	1	1	2	
	12	1	1	1	1	1	1	1	1	1	1	1	1	1	1	1	1	1	1
	13	1	1	1	1	1	1	1	1	1	1	1	1	1	1	1	1	1	1
	14	1	1	1	1	1	1	1	1	1	1	1	1	1	1	1	1	1	1

- 1 406.0340
- 2 406.0340 + 406.0099
- 3 406.0340 + 406.0094

- Het wordt aangeraden directe zonnestraling te vermijden

Raadpleeg het hoofdstuk ‘Oplossingen’ om alle details van elke afmeting te zien.

De verbuiging van het profiel is te wijten aan de snelle opwarming door de zonnestraling en is tijdelijk. Het fenomeen komt voor op specifieke momenten van specifieke dagen in het jaar. Bij het opstellen van de grafieken werd rekening gehouden met de maximale mogelijke verbuiging die kan voorkomen wanneer het profiel aan de maximale zonnestraling blootgesteld wordt, en met de specifieke buitentemperatuur. Een voor het project specifieke berekening kan vereist zijn om de functionaliteit van het element te beoordelen.

HI isolatie variant – Slot zijde – Gemiddelde buitentemperatuur in de zomer = 35°C

**Zuid oriëntatie**

		Vleugel hoogte (mm)																
		2000	2100	2200	2300	2400	2500	2600	2700	2800	2900	3000	3100	3200	3300	3400	3500	3600
Kleur	1	1	1	1	1	1	2	2	2	2	3	3	3	3	3	3	-	-
	2	1	1	1	1	1	1	2	2	2	2	3	3	3	3	3	3	-
	3	1	1	1	1	1	1	2	2	2	2	2	3	3	3	3	3	3
	4	1	1	1	1	1	1	2	2	2	2	2	3	3	3	3	3	3
	5	1	1	1	1	1	1	1	2	2	2	2	2	3	3	3	3	3
	6	1	1	1	1	1	1	1	1	2	2	2	2	2	3	3	3	3
	7	1	1	1	1	1	1	1	1	1	2	2	2	2	2	3	3	3
	8	1	1	1	1	1	1	1	1	1	1	2	2	2	2	2	3	3
	9	1	1	1	1	1	1	1	1	1	1	2	2	2	2	2	3	3
	10	1	1	1	1	1	1	1	1	1	1	1	1	1	2	2	2	2
	11	1	1	1	1	1	1	1	1	1	1	1	1	1	1	2	2	2
	12	1	1	1	1	1	1	1	1	1	1	1	1	1	1	1	2	2
	13	1	1	1	1	1	1	1	1	1	1	1	1	1	1	1	1	2
	14	1	1	1	1	1	1	1	1	1	1	1	1	1	1	1	1	1

**Oost/West oriëntatie**

		Vleugel hoogte (mm)																
		2000	2100	2200	2300	2400	2500	2600	2700	2800	2900	3000	3100	3200	3300	3400	3500	3600
Kleur	1	1	1	1	2	2	2	2	2	3	3	3	3	3	-	-	-	-
	2	1	1	1	1	2	2	2	2	3	3	3	3	3	-	-	-	-
	3	1	1	1	1	2	2	2	2	2	3	3	3	3	3	-	-	-
	4	1	1	1	1	1	2	2	2	2	3	3	3	3	3	3	-	-
	5	1	1	1	1	1	1	2	2	2	2	3	3	3	3	3	3	-
	6	1	1	1	1	1	1	2	2	2	2	2	3	3	3	3	3	3
	7	1	1	1	1	1	1	1	2	2	2	2	2	3	3	3	3	3
	8	1	1	1	1	1	1	1	1	2	2	2	2	2	3	3	3	3
	9	1	1	1	1	1	1	1	1	1	2	2	2	2	2	3	3	3
	10	1	1	1	1	1	1	1	1	1	1	2	2	2	2	2	3	3
	11	1	1	1	1	1	1	1	1	1	1	1	2	2	2	2	2	2
	12	1	1	1	1	1	1	1	1	1	1	1	1	1	2	2	2	2
	13	1	1	1	1	1	1	1	1	1	1	1	1	1	1	1	1	2
	14	1	1	1	1	1	1	1	1	1	1	1	1	1	1	1	1	1

- 1 406.0340
- 2 406.0340 + 406.0099
- 3 406.0340 + 406.0094

- Het wordt aangeraden directe zonnestraling te vermijden

Raadpleeg het hoofdstuk ‘Oplossingen’ om alle details van elke afmeting te zien.

De verbuiging van het profiel is te wijten aan de snelle opwarming door de zonnestraling en is tijdelijk. Het fenomeen komt voor op specifieke momenten van specifieke dagen in het jaar. Bij het opstellen van de grafieken werd rekening gehouden met de maximale mogelijke verbuiging die kan voorkomen wanneer het profiel aan de maximale zonnestraling blootgesteld wordt, en met de specifieke buitentemperatuur. Een voor het project specifieke berekening kan vereist zijn om de functionaliteit van het element te beoordelen.

Standaard/HI isolatie variant – Wisselprofiel sectie – Gemiddelde buitentemperatuur in de zomer = 25 tot 35°C

		Vleugel hoogte (mm)																
		2000	2100	2200	2300	2400	2500	2600	2700	2800	2900	3000	3100	3200	3300	3400	3500	3600
Kleur	1	1	1	1	1	1	1	1	1	1	1	1	1	1	1	1	2	2
	2	1	1	1	1	1	1	1	1	1	1	1	1	1	1	1	1	2
	3	1	1	1	1	1	1	1	1	1	1	1	1	1	1	1	1	1
	4	1	1	1	1	1	1	1	1	1	1	1	1	1	1	1	1	1
	5	1	1	1	1	1	1	1	1	1	1	1	1	1	1	1	1	1
	6	1	1	1	1	1	1	1	1	1	1	1	1	1	1	1	1	1
	7	1	1	1	1	1	1	1	1	1	1	1	1	1	1	1	1	1
	8	1	1	1	1	1	1	1	1	1	1	1	1	1	1	1	1	1
	9	1	1	1	1	1	1	1	1	1	1	1	1	1	1	1	1	1
	10	1	1	1	1	1	1	1	1	1	1	1	1	1	1	1	1	1
	11	1	1	1	1	1	1	1	1	1	1	1	1	1	1	1	1	1
	12	1	1	1	1	1	1	1	1	1	1	1	1	1	1	1	1	1
	13	1	1	1	1	1	1	1	1	1	1	1	1	1	1	1	1	1
	14	1	1	1	1	1	1	1	1	1	1	1	1	1	1	1	1	1

- 1 406.0335 / 406.0330
- 2 406.0335+406.0092 / 406.0335+406.0094 / 406.0335+406.0096 / 406.0330+406.0092 / 406.0330+406.0094

Raadpleeg het hoofdstuk ‘Oplossingen’ om alle details van elke afmeting te zien.

De verbuiging van het profiel is te wijten aan de snelle opwarming door de zonnestraling en is tijdelijk. Het fenomeen komt voor op specifieke momenten van specifieke dagen in het jaar. Bij het opstellen van de grafieken werd rekening gehouden met de maximale mogelijke verbuiging die kan voorkomen wanneer het profiel aan de maximale zonnestraling blootgesteld wordt, en met de specifieke buitentemperatuur. Een voor het project specifieke berekening kan vereist zijn om de functionaliteit van het element te beoordelen.

# EFFET BIMÉTALLIQUE SUR LES PORTES COULISSANTES

## I. Description de l'effet bimétal

L'effet bimétal se manifeste sur les portes coulissantes lorsqu'il existe un différentiel thermique entre les demi-coques intérieure et extérieure d'un profil à rupture thermique. C'est le cas dans lorsqu'il fait chaud à l'extérieur ainsi que dans les environnements extrêmement froids.

Deux types de déflexion par effet bimétal ont été observés sur les portes coulissantes.

- Échauffement de la cavité : Les profils de la section de chevauchement s'incurvent l'un vers l'autre lorsque le vantail est ouvert.
- Rayonnement solaire direct : les profils s'incurvent dans une même direction.

### I.1 Échauffement de la cavité

Lors de l'ouverture d'une porte coulissante, une cavité se crée entre les deux vitrages. Si le soleil chauffe l'air présent dans cette cavité et si les profils sont de couleur claire (groupe 7-14, voir **Error! Reference source not found.**), les profils de la section de chevauchement vont s'incurver l'un vers l'autre. Lors de la fermeture de la porte, les profils d'inversion en PVC risquent de s'endommager mutuellement.

### I.2 Rayonnement solaire direct

Le profil du vantail côté fermeture (que ce soit en position ouverte ou fermée) et les profils de la section de chevauchement (en position fermée) s'incurveront temporairement s'ils sont exposés à échauffement dû au rayonnement solaire. La couleur du profil, l'emplacement et l'orientation de la porte coulissante ont un impact significatif sur cet effet. Le rayonnement solaire s'exerce plus directement sur les façades orientées à l'est et à l'ouest étant donné que les profils sont verticaux et que le soleil est plus bas sur l'horizon à ces azimuts.

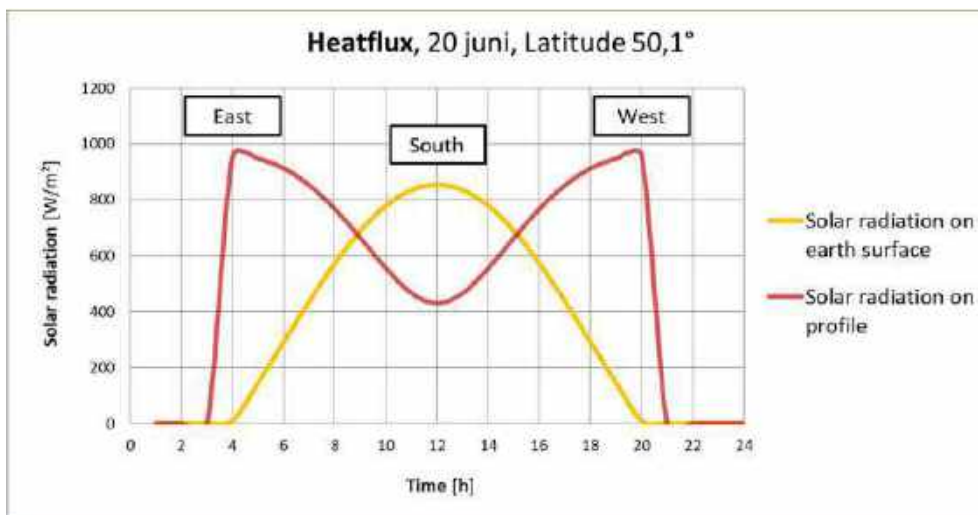

Figure 1: Rayonnement solaire dans l'été

Le rayonnement frappant effectivement les profils sera influencé par la situation réelle (p.ex. la présence de bâtiments avoisinants, d'une protection solaire ou d'arbres, la couverture nuageuse, les conditions atmosphériques,...) qui peut entraîner un ombrage supplémentaire. L'ensoleillement doit donc être évalué au cas par cas, en fonction du projet.

### I.2.1 Le rayonnement depend de la couleur

La couleur du profil influence la température de la coque externe qui est déterminée par l'absorption de chaleur correspondant à la couleur en question. Plus la couleur est foncée (groupe 1), plus la situation est délicate. Les différentes couleurs ont été regroupées en fonction de leur comportement. Les groupes de couleurs (RAL) suivants présentent une réaction similaire lorsqu'ils sont exposés à un rayonnement solaire :

1	5004 8022 9005	<i>Avec RAL 9005 – Noir foncé</i>
2	3004 3005 3007 4007 5003 5008 5011 5013 5020 5022 6005 6007 6008 6009 6012 6022 7021 8014 8016 8017 8019 9004 9011 9017	
3	3003 3009 3011 5000 5001 5002 5010 6004 6006 6014 6015 6020 7016 7022 7024 7026 8011 8012 8015 8028	
4	3000 3001 3002 3013 3027 4002 4006 5005 5009 5017 5019 6002 6003 6016 6026 6028 7009 7010 7011 7013 7015 7043 8002 8003 8007 8008 8024	
5	2002 3016 3020 3031 4008 5007 5021 5023 6000 6001 6010 6025 6029 7006 7008 7012 7031 7039 8004 8025	
6	2001 3017 3018 4001 4005 4010 5014 5015 6011 6013 6017 6024 6032 7003 7005 8000 8001 8023	
7	1027 2004 2009 2010 2012 3022 4003 5012 5018 6018 6033 7000 7002 7023 7033 7034 7037 7046	
8	1005 1011 1019 1020 1024 2000 2008 2011 3012 3014 4009 5024 6021 7001 7030 7036 7042 7045	
9	1006 1007 2003 6034 7004 7040	
10	1001 1002 1012 1028 1033 1034 3015 6027 7032 7038 7044	
11	1000 1003 1017 1021 1023 6019 7035	
12	1014 1018 7047 9018	
13	1013 1015 1016	
14	9003 9010 9016	<i>Avec RAL 9016 – Blanc signalisation</i>

Tableau 1 : Classification en groupes des différentes couleurs

## II. Explication du tableau

L'effet bimétal est influencé par le **rayonnement solaire** à la surface du profil, les **températures de l'air extérieur** et l'**orientation** de la porte coulissante.

Outre deux variations de températures extérieures, vous trouverez ci-dessous les tableaux correspondant aux façades orientées est/ouest ainsi que celui des façades orientées vers le sud. Veuillez choisir la situation correspondant le mieux à votre site d'installation.

### ÉTAPES DE SÉLECTION :

- Choisissez la variante d'isolation (Standard ou HI).
- Consultez les tableaux disponibles pour les profils du côté fermeture, en fonction de l'orientation et de la température.
- Sélectionnez la température externe moyenne des mois d'été correspondant le mieux à votre site.
- Choisissez l'orientation de la façade.
- Identifiez les mesures à prendre pour minimiser la déflexion temporaire due à l'effet bimétal.
- Consultez le tableau disponible pour les profils de la section de chevauchement (un seul tableau applicable pour toutes les orientations et pour des températures estivales moyennes de l'air extérieur allant jusqu'à  $T_{ext}=35^{\circ}C$ ).
- Consultez les détails des mesures nécessaires au chapitre « Solutions ».

Pour une température moyenne de l'air extérieur jusqu'à  $25^{\circ}C$  pendant les mois d'été, veuillez sélectionner les tableaux indiquant une  $T_{ext} = 25^{\circ}C$ . Pour une température moyenne de l'air extérieur comprise entre 26 et  $35^{\circ}C$  durant les mois d'été, veuillez sélectionner les tableaux indiquant une  $T_{ext} = 35^{\circ}C$ . En cas de températures externes supérieures, il est nécessaire de procéder à un calcul spécifique au projet.

## III. Solutions

### III.1 Côté fermeture

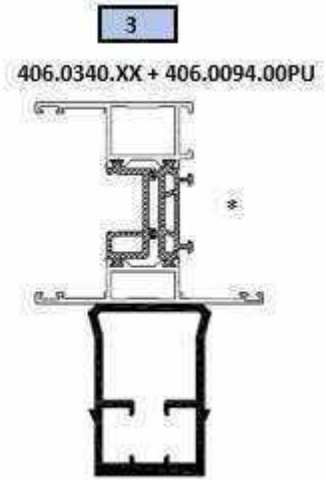
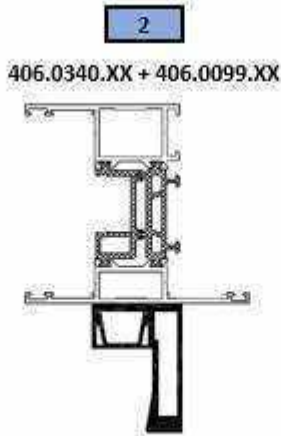

L'exposition des profils à un rayonnement solaire direct n'est pas recommandée.\*\*

Reynaers propose des systèmes de protection solaire dans sa gamme (BS 30, BS 100).

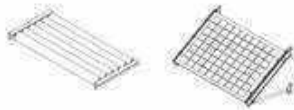

### III.2 Chicane

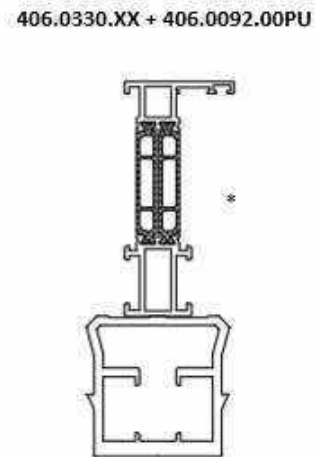
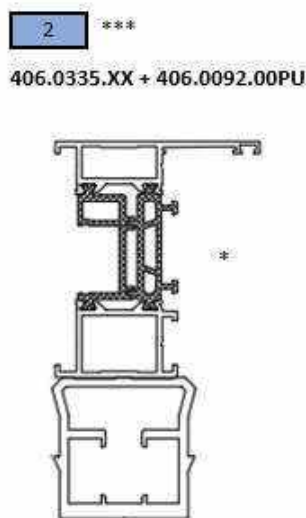
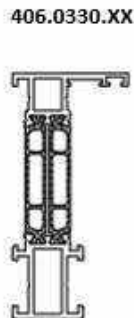
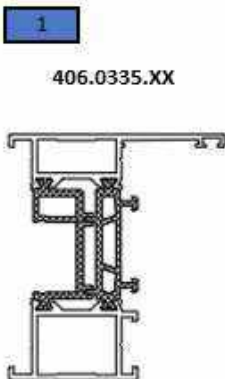

- \* Tout renforcement qui atteint la valeur Ix de cette combinaison peut être utilisé.
- \*\* Un calcul spécifique au projet peut être nécessaire pour évaluer la fonctionnalité de l'élément.
- \*\*\* Pour la **section de chevauchement**, le renfort doit être positionné sur le **profil extérieur**.

Variante d'isolation standard – Côté fermeture – Température estivale moyenne de l'air extérieur = 25°C

**Orientation sud**

		Hauteur du vantail (mm)																
		2000	2100	2200	2300	2400	2500	2600	2700	2800	2900	3000	3100	3200	3300	3400	3500	3600
Gamme de couleur	1	1	1	1	1	1	1	1	2	2	2	2	2	3	3	3	3	
	2	1	1	1	1	1	1	1	1	2	2	2	2	2	3	3	3	
	3	1	1	1	1	1	1	1	1	1	2	2	2	2	2	3	3	
	4	1	1	1	1	1	1	1	1	1	2	2	2	2	2	3	3	
	5	1	1	1	1	1	1	1	1	1	1	2	2	2	2	2	3	
	6	1	1	1	1	1	1	1	1	1	1	1	2	2	2	2	2	
	7	1	1	1	1	1	1	1	1	1	1	1	1	1	2	2	2	
	8	1	1	1	1	1	1	1	1	1	1	1	1	1	1	2	2	
	9	1	1	1	1	1	1	1	1	1	1	1	1	1	1	2	2	
	10	1	1	1	1	1	1	1	1	1	1	1	1	1	1	1	1	
	11	1	1	1	1	1	1	1	1	1	1	1	1	1	1	1	1	
	12	1	1	1	1	1	1	1	1	1	1	1	1	1	1	1	1	
	13	1	1	1	1	1	1	1	1	1	1	1	1	1	1	1	1	
	14	1	1	1	1	1	1	1	1	1	1	1	1	1	1	1	1	

**Orientation est/ouest**

		Hauteur du vantail (mm)																
		2000	2100	2200	2300	2400	2500	2600	2700	2800	2900	3000	3100	3200	3300	3400	3500	3600
Gamme de couleur	1	1	1	1	1	1	2	2	2	2	3	3	3	3	3	3	3	
	2	1	1	1	1	1	1	2	2	2	2	3	3	3	3	3	3	
	3	1	1	1	1	1	1	2	2	2	2	2	3	3	3	3	3	
	4	1	1	1	1	1	1	1	2	2	2	2	2	3	3	3	3	
	5	1	1	1	1	1	1	1	1	2	2	2	2	2	3	3	3	
	6	1	1	1	1	1	1	1	1	1	2	2	2	2	2	3	3	
	7	1	1	1	1	1	1	1	1	1	1	2	2	2	2	2	3	
	8	1	1	1	1	1	1	1	1	1	1	1	2	2	2	2	2	
	9	1	1	1	1	1	1	1	1	1	1	1	1	1	2	2	2	
	10	1	1	1	1	1	1	1	1	1	1	1	1	1	1	2	2	
	11	1	1	1	1	1	1	1	1	1	1	1	1	1	1	1	1	
	12	1	1	1	1	1	1	1	1	1	1	1	1	1	1	1	1	
	13	1	1	1	1	1	1	1	1	1	1	1	1	1	1	1	1	
	14	1	1	1	1	1	1	1	1	1	1	1	1	1	1	1	1	

- 1 406.0340
- 2 406.0340 + 406.0099
- 3 406.0340 + 406.0094

- Il est recommandé d'éviter tout rayonnement solaire direct

**Veillez vous référer au chapitre « Solutions » pour obtenir tous les détails de chaque mesure.**

La déflexion du profil est due à son échauffement rapide sous l'effet du rayonnement solaire; elle est temporaire. Ce phénomène survient à certaines heures spécifiques de certains jours spécifiques de l'année. Les tableaux ont été composés en tenant compte de la déflexion maximale possible pouvant survenir en cas d'exposition au rayonnement solaire le plus intense possible et à une température spécifique de l'air extérieur. Un calcul spécifique au projet peut être nécessaire pour évaluer la fonctionnalité de l'élément.

**Variante d'isolation standard – Côté fermeture – Température estivale moyenne de l'air extérieur = 35°C**

**Orientation sud**

		Hauteur du vantail (mm)																
		2000	2100	2200	2300	2400	2500	2600	2700	2800	2900	3000	3100	3200	3300	3400	3500	3600
Gamme de couleur	1	1	1	1	1	1	1	2	2	2	2	2	3	3	3	3	-	-
	2	1	1	1	1	1	1	1	2	2	2	2	3	3	3	3	3	-
	3	1	1	1	1	1	1	1	1	2	2	2	2	3	3	3	3	-
	4	1	1	1	1	1	1	1	1	2	2	2	2	3	3	3	3	-
	5	1	1	1	1	1	1	1	1	1	2	2	2	2	3	3	3	3
	6	1	1	1	1	1	1	1	1	1	1	2	2	2	2	3	3	3
	7	1	1	1	1	1	1	1	1	1	1	1	2	2	2	2	3	3
	8	1	1	1	1	1	1	1	1	1	1	1	1	2	2	2	2	2
	9	1	1	1	1	1	1	1	1	1	1	1	1	2	2	2	2	2
	10	1	1	1	1	1	1	1	1	1	1	1	1	1	2	2	2	2
	11	1	1	1	1	1	1	1	1	1	1	1	1	1	1	2	2	2
	12	1	1	1	1	1	1	1	1	1	1	1	1	1	1	1	1	2
	13	1	1	1	1	1	1	1	1	1	1	1	1	1	1	1	1	1
	14	1	1	1	1	1	1	1	1	1	1	1	1	1	1	1	1	1

**Orientation est/ouest**

		Hauteur du vantail (mm)																
		2000	2100	2200	2300	2400	2500	2600	2700	2800	2900	3000	3100	3200	3300	3400	3500	3600
Gamme de couleur	1	1	1	1	1	1	2	2	2	2	3	3	3	3	-	-	-	-
	2	1	1	1	1	1	2	2	2	2	3	3	3	3	-	-	-	-
	3	1	1	1	1	1	1	2	2	2	2	3	3	3	3	-	-	-
	4	1	1	1	1	1	1	2	2	2	2	2	3	3	3	3	-	-
	5	1	1	1	1	1	1	1	2	2	2	2	3	3	3	3	3	-
	6	1	1	1	1	1	1	1	1	2	2	2	2	3	3	3	3	-
	7	1	1	1	1	1	1	1	1	1	2	2	2	2	3	3	3	3
	8	1	1	1	1	1	1	1	1	1	1	2	2	2	2	3	3	3
	9	1	1	1	1	1	1	1	1	1	1	1	2	2	2	2	3	3
	10	1	1	1	1	1	1	1	1	1	1	1	1	2	2	2	2	2
	11	1	1	1	1	1	1	1	1	1	1	1	1	1	2	2	2	2
	12	1	1	1	1	1	1	1	1	1	1	1	1	1	1	2	2	2
	13	1	1	1	1	1	1	1	1	1	1	1	1	1	1	1	1	2
	14	1	1	1	1	1	1	1	1	1	1	1	1	1	1	1	1	1

- 1 406.0340
- 2 406.0340 + 406.0099
- 3 406.0340 + 406.0094

- Il est recommandé d'éviter tout rayonnement solaire direct

**Veillez vous référer au chapitre « Solutions » pour obtenir tous les détails de chaque mesure.**

**La déflexion du profil est due à son échauffement rapide sous l'effet du rayonnement solaire; elle est temporaire. Ce phénomène survient à certaines heures spécifiques de certains jours spécifiques de l'année. Les tableaux ont été composés en tenant compte de la déflexion maximale possible pouvant survenir en cas d'exposition au rayonnement solaire le plus intense possible et à une température spécifique de l'air extérieur. Un calcul spécifique au projet peut être nécessaire pour évaluer la fonctionnalité de l'élément.**

Variante d'isolation HI – Côté fermeture – Température estivale moyenne de l'air extérieur = 25°C

Orientation sud

		Hauteur du vantail (mm)																
		2000	2100	2200	2300	2400	2500	2600	2700	2800	2900	3000	3100	3200	3300	3400	3500	3600
Gamme de couleur	1	1	1	1	1	1	1	1	2	2	2	2	3	3	3	3	3	3
	2	1	1	1	1	1	1	1	2	2	2	2	3	3	3	3	3	3
	3	1	1	1	1	1	1	1	1	2	2	2	2	3	3	3	3	3
	4	1	1	1	1	1	1	1	1	1	2	2	2	2	3	3	3	3
	5	1	1	1	1	1	1	1	1	1	1	2	2	2	2	2	3	3
	6	1	1	1	1	1	1	1	1	1	1	1	2	2	2	2	2	3
	7	1	1	1	1	1	1	1	1	1	1	1	1	2	2	2	2	2
	8	1	1	1	1	1	1	1	1	1	1	1	1	1	1	2	2	2
	9	1	1	1	1	1	1	1	1	1	1	1	1	1	1	2	2	2
	10	1	1	1	1	1	1	1	1	1	1	1	1	1	1	1	1	1
	11	1	1	1	1	1	1	1	1	1	1	1	1	1	1	1	1	1
	12	1	1	1	1	1	1	1	1	1	1	1	1	1	1	1	1	1
	13	1	1	1	1	1	1	1	1	1	1	1	1	1	1	1	1	1
	14	1	1	1	1	1	1	1	1	1	1	1	1	1	1	1	1	1

Orientation est/ouest

		Hauteur du vantail (mm)																
		2000	2100	2200	2300	2400	2500	2600	2700	2800	2900	3000	3100	3200	3300	3400	3500	3600
Gamme de couleur	1	1	1	1	1	1	2	2	2	2	3	3	3	3	3	3	3	3
	2	1	1	1	1	1	2	2	2	2	2	3	3	3	3	3	3	3
	3	1	1	1	1	1	1	2	2	2	2	3	3	3	3	3	3	3
	4	1	1	1	1	1	1	1	2	2	2	2	3	3	3	3	3	3
	5	1	1	1	1	1	1	1	1	2	2	2	2	3	3	3	3	3
	6	1	1	1	1	1	1	1	1	1	2	2	2	2	3	3	3	3
	7	1	1	1	1	1	1	1	1	1	1	2	2	2	2	3	3	3
	8	1	1	1	1	1	1	1	1	1	1	1	2	2	2	2	2	3
	9	1	1	1	1	1	1	1	1	1	1	1	1	2	2	2	2	2
	10	1	1	1	1	1	1	1	1	1	1	1	1	1	2	2	2	2
	11	1	1	1	1	1	1	1	1	1	1	1	1	1	1	1	1	2
	12	1	1	1	1	1	1	1	1	1	1	1	1	1	1	1	1	1
	13	1	1	1	1	1	1	1	1	1	1	1	1	1	1	1	1	1
	14	1	1	1	1	1	1	1	1	1	1	1	1	1	1	1	1	1

- 1 406.0340
- 2 406.0340 + 406.0099
- 3 406.0340 + 406.0094

- Il est recommandé d'éviter tout rayonnement solaire direct

Veuillez vous référer au chapitre « Solutions » pour obtenir tous les détails de chaque mesure.

La déflexion du profil est due à son échauffement rapide sous l'effet du rayonnement solaire; elle est temporaire. Ce phénomène survient à certaines heures spécifiques de certains jours spécifiques de l'année. Les tableaux ont été composés en tenant compte de la déflexion maximale possible pouvant survenir en cas d'exposition au rayonnement solaire le plus intense possible et à une température spécifique de l'air extérieur. Un calcul spécifique au projet peut être nécessaire pour évaluer la fonctionnalité de l'élément.

**Variante d'isolation HI – Côté fermeture – Température estivale moyenne de l'air extérieur = 35°C**

**Orientation sud**

		Hauteur du vantail (mm)																
		2000	2100	2200	2300	2400	2500	2600	2700	2800	2900	3000	3100	3200	3300	3400	3500	3600
Gamme de couleur	1	1	1	1	1	1	2	2	2	2	3	3	3	3	3	3	-	-
	2	1	1	1	1	1	1	2	2	2	2	3	3	3	3	3	3	-
	3	1	1	1	1	1	1	2	2	2	2	2	3	3	3	3	3	3
	4	1	1	1	1	1	1	2	2	2	2	2	3	3	3	3	3	3
	5	1	1	1	1	1	1	1	2	2	2	2	2	3	3	3	3	3
	6	1	1	1	1	1	1	1	1	2	2	2	2	2	3	3	3	3
	7	1	1	1	1	1	1	1	1	1	2	2	2	2	2	3	3	3
	8	1	1	1	1	1	1	1	1	1	1	2	2	2	2	2	3	3
	9	1	1	1	1	1	1	1	1	1	1	2	2	2	2	2	3	3
	10	1	1	1	1	1	1	1	1	1	1	1	1	1	2	2	2	2
	11	1	1	1	1	1	1	1	1	1	1	1	1	1	2	2	2	2
	12	1	1	1	1	1	1	1	1	1	1	1	1	1	1	1	2	2
	13	1	1	1	1	1	1	1	1	1	1	1	1	1	1	1	1	2
	14	1	1	1	1	1	1	1	1	1	1	1	1	1	1	1	1	1

**Orientation est/ouest**

		Hauteur du vantail (mm)																
		2000	2100	2200	2300	2400	2500	2600	2700	2800	2900	3000	3100	3200	3300	3400	3500	3600
Gamme de couleur	1	1	1	1	2	2	2	2	2	3	3	3	3	3	-	-	-	-
	2	1	1	1	1	2	2	2	2	3	3	3	3	3	-	-	-	-
	3	1	1	1	1	2	2	2	2	2	3	3	3	3	3	-	-	-
	4	1	1	1	1	1	2	2	2	2	3	3	3	3	3	3	-	-
	5	1	1	1	1	1	1	2	2	2	2	3	3	3	3	3	3	-
	6	1	1	1	1	1	1	2	2	2	2	2	3	3	3	3	3	3
	7	1	1	1	1	1	1	1	2	2	2	2	2	3	3	3	3	3
	8	1	1	1	1	1	1	1	1	2	2	2	2	2	3	3	3	3
	9	1	1	1	1	1	1	1	1	1	2	2	2	2	2	3	3	3
	10	1	1	1	1	1	1	1	1	1	1	2	2	2	2	2	3	3
	11	1	1	1	1	1	1	1	1	1	1	1	2	2	2	2	2	2
	12	1	1	1	1	1	1	1	1	1	1	1	1	1	2	2	2	2
	13	1	1	1	1	1	1	1	1	1	1	1	1	1	1	1	2	2
	14	1	1	1	1	1	1	1	1	1	1	1	1	1	1	1	1	2

- 1 406.0340
- 2 406.0340 + 406.0099
- 3 406.0340 + 406.0094
- Il est recommandé d'éviter tout rayonnement solaire direct

**Veillez vous référer au chapitre « Solutions » pour obtenir tous les détails de chaque mesure.**

**La déflexion du profil est due à son échauffement rapide sous l'effet du rayonnement solaire; elle est temporaire. Ce phénomène survient à certaines heures spécifiques de certains jours spécifiques de l'année. Les tableaux ont été composés en tenant compte de la déflexion maximale possible pouvant survenir en cas d'exposition au rayonnement solaire le plus intense possible et à une température spécifique de l'air extérieur. Un calcul spécifique au projet peut être nécessaire pour évaluer la fonctionnalité de l'élément.**

Variante d'isolation Standard/HI – Chicane – Température estivale moyenne de l'air extérieur = 25 à 35°C

Sud/Est/Ouest orientation

Vleugel hoogte (mm)

	2000	2100	2200	2300	2400	2500	2600	2700	2800	2900	3000	3100	3200	3300	3400	3500	3600	
1	1	1	1	1	1	1	1	1	1	1	1	1	1	1	1	1	2	2
2	1	1	1	1	1	1	1	1	1	1	1	1	1	1	1	1	1	2
3	1	1	1	1	1	1	1	1	1	1	1	1	1	1	1	1	1	1
4	1	1	1	1	1	1	1	1	1	1	1	1	1	1	1	1	1	1
5	1	1	1	1	1	1	1	1	1	1	1	1	1	1	1	1	1	1
6	1	1	1	1	1	1	1	1	1	1	1	1	1	1	1	1	1	1
7	1	1	1	1	1	1	1	1	1	1	1	1	1	1	1	1	1	1
8	1	1	1	1	1	1	1	1	1	1	1	1	1	1	1	1	1	1
9	1	1	1	1	1	1	1	1	1	1	1	1	1	1	1	1	1	1
10	1	1	1	1	1	1	1	1	1	1	1	1	1	1	1	1	1	1
11	1	1	1	1	1	1	1	1	1	1	1	1	1	1	1	1	1	1
12	1	1	1	1	1	1	1	1	1	1	1	1	1	1	1	1	1	1
13	1	1	1	1	1	1	1	1	1	1	1	1	1	1	1	1	1	1
14	1	1	1	1	1	1	1	1	1	1	1	1	1	1	1	1	1	1

- 1 406.0335 / 406.0330
- 2 406.0335+406.0092 / 406.0335+406.0094 / 406.0335+406.0096 / 406.0330+406.0092 / 406.0330+406.0094

Veillez vous référer au chapitre « Solutions » pour obtenir tous les détails de chaque mesure.

La déflexion du profil est due à son échauffement rapide sous l'effet du rayonnement solaire; elle est temporaire. Ce phénomène survient à certaines heures spécifiques de certains jours spécifiques de l'année. Les tableaux ont été composés en tenant compte de la déflexion maximale possible pouvant survenir en cas d'exposition au rayonnement solaire le plus intense possible et à une température spécifique de l'air extérieur. Un calcul spécifique au projet peut être nécessaire pour évaluer la fonctionnalité de l'élément.

# BI-METAL EFFECT ON SLIDING DOORS

## I. Description of bi-metal effect

The bi-metal effect will occur on sliding doors when there is a temperature difference between the inner and outer half scale of a thermally broken profile. This is the case for warm exterior environments and extreme cold environments. The bi-metal effect due to solar radiation is much stronger than the effect of cold conditions in moderate climates (temperatures down to -20°C).

For sliding doors two types of bi-metal bending have been observed.

- Heating of the cavity: Profiles of the meeting section bend towards each other when vent is opened.
- Direct solar radiation: bending of the profiles in one direction

### I.1 Heating of the cavity

When a sliding door is opened there is a cavity between the two glass panes. If the sun heats up this cavity and if the profiles have a light colour (group 7-14 see I.2.1) the meeting section profiles will bend towards each other. If the door is closed the PVC switch profiles can damage each other.

### I.2 Direct solar radiation

The vent profile on the lock side (open and closed position) and the profiles of the meeting section (closed position) will temporarily bend when heated up by solar radiation. The colour of the profile, the location and orientation of the sliding door have a significant influence. The solar radiation is more direct on the East and West oriented facades, due to the profiles being vertical and the low position of the sun at these orientations.

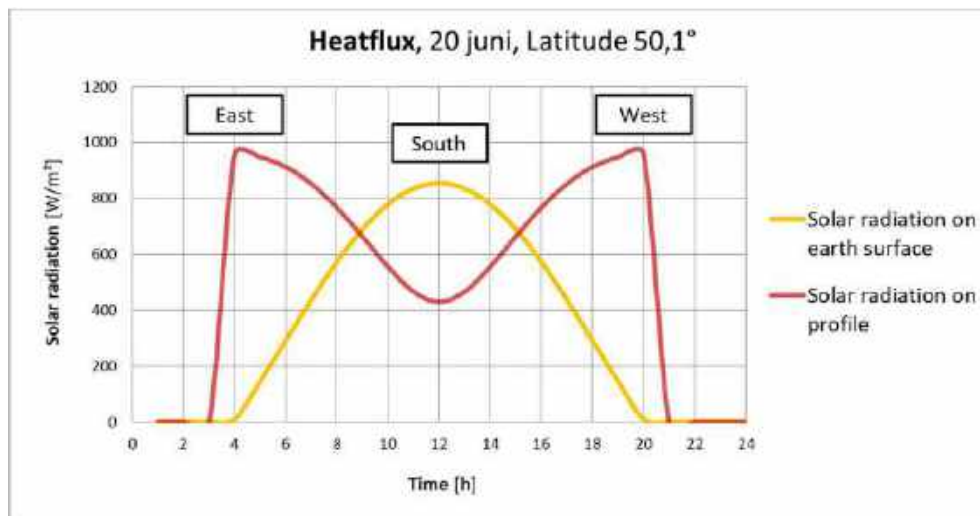

Figure 1: Solar radiation for summer day

The actual radiation on the profiles will be influenced by the real situation (e.g. surrounding buildings, solar shading, trees, cloud coverage, atmospheric conditions etc.) which might cause additional shading and should be evaluated in function of the project.

### I.2.1 Radiation: colour dependent

The colour of the profile influences the temperature of the outer scale and is determined by the heat absorption of that colour. The darker the colour (group 1), the more critical. The different colours have been grouped based on their behaviour. Following groups of colours (RAL) will act similarly when exposed to solar radiation:

1	5004 8022 9005	<i>Where RAL 9005 – Jet Black</i>
2	3004 3005 3007 4007 5003 5008 5011 5013 5020 5022 6005 6007 6008 6009 6012 6022 7021 8014 8016 8017 8019 9004 9011 9017	
3	3003 3009 3011 5000 5001 5002 5010 6004 6006 6014 6015 6020 7016 7022 7024 7026 8011 8012 8015 8028	
4	3000 3001 3002 3013 3027 4002 4006 5005 5009 5017 5019 6002 6003 6016 6026 6028 7009 7010 7011 7013 7015 7043 8002 8003 8007 8008 8024	
5	2002 3016 3020 3031 4008 5007 5021 5023 6000 6001 6010 6025 6029 7006 7008 7012 7031 7039 8004 8025	
6	2001 3017 3018 4001 4005 4010 5014 5015 6011 6013 6017 6024 6032 7003 7005 8000 8001 8023	
7	1027 2004 2009 2010 2012 3022 4003 5012 5018 6018 6033 7000 7002 7023 7033 7034 7037 7046	
8	1005 1011 1019 1020 1024 2000 2008 2011 3012 3014 4009 5024 6021 7001 7030 7036 7042 7045	
9	1006 1007 2003 6034 7004 7040	
10	1001 1002 1012 1028 1033 1034 3015 6027 7032 7038 7044	
11	1000 1003 1017 1021 1023 6019 7035	
12	1014 1018 7047 9018	
13	1013 1015 1016	
14	9003 9010 9016	<i>Where RAL 9016 – Traffic white</i>

Table 1: Grouping of the different colour

## II. Chart explanation

The bimetal effect is influenced by the **solar radiation** on the profile surface, the **external air temperatures** and the **orientation** of the sliding door.

Below there are charts for East/West oriented facades and South oriented facades in addition to two different exterior temperatures. Please select the situation closest to your location.

### SELECTION STEPS:

- Select insulation variant (Standard or HI)
- Charts available for lock side profiles based on orientation and temperature
- Select most applicable for the location average external temperature during summer months
- Select orientation of façade
- Find measures that need to be taken to minimize the temporary deflection due to the bimetal effect
- Chart available for meeting section profiles (one chart applicable for all orientations and for average external summer temperatures up to Text=35°C)
- Look in chapter 'Solutions' for details of the needed measures

For average external air temperature up to 25°C during summer months please select the charts with Text = 25°C. For average external air temperature between 26-35°C during summer months please select the charts with Text = 35°C. For higher external temperatures a project related calculation will be needed.

## III. Solutions

### III.1 Lock side

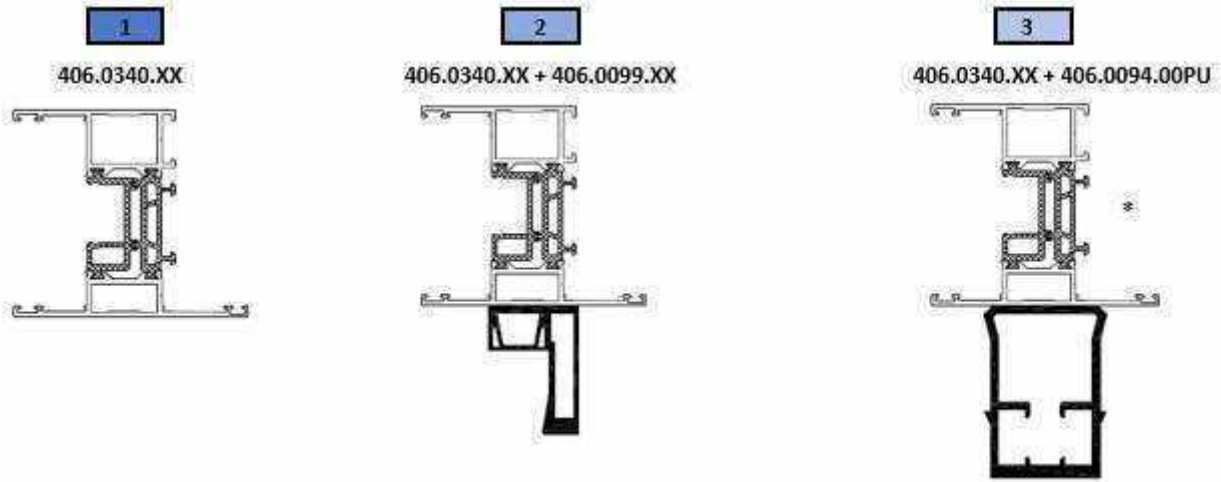

Direct solar radiation on the profiles is not recommended.\*\*

Reynaers has solar shading systems in its range (BS 30, BS 100).

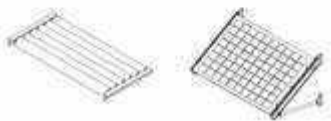

### III.2 Meeting section

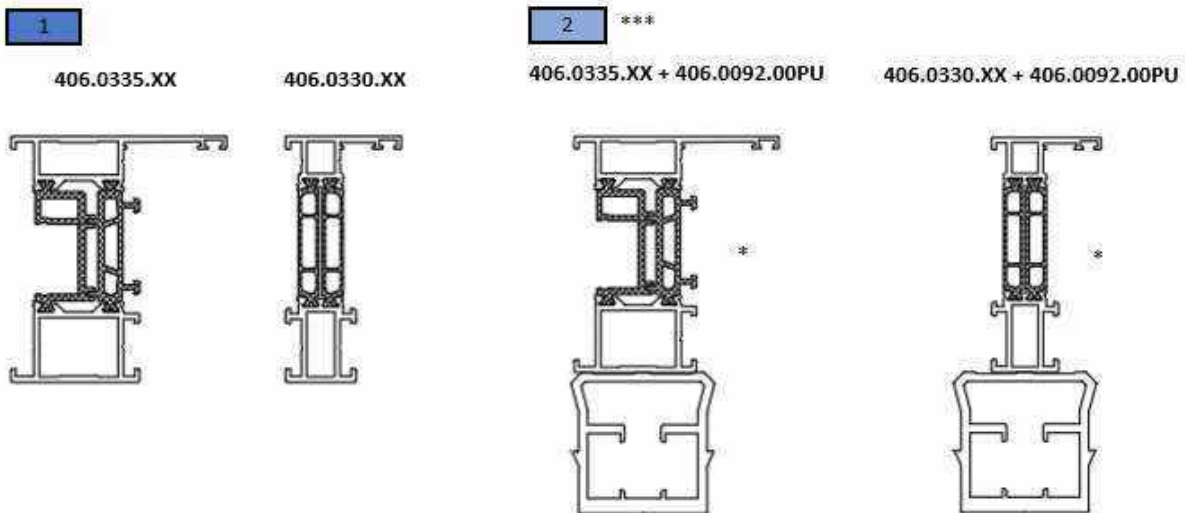

- \* Any reinforcement that reaches the Ix value of this combination can be used.
- \*\* A project related calculation can be requested in order to evaluate the functionality of the element.
- \*\*\* For the meeting section the reinforcement should be placed on the exterior profile.

Standard insulation variant – Lock side – Average external summer temperature = 25°C

South orientation

		Vent height (mm)																
		2000	2100	2200	2300	2400	2500	2600	2700	2800	2900	3000	3100	3200	3300	3400	3500	3600
Colour range	1	1	1	1	1	1	1	1	1	2	2	2	2	2	3	3	3	3
	2	1	1	1	1	1	1	1	1	2	2	2	2	2	3	3	3	3
	3	1	1	1	1	1	1	1	1	1	2	2	2	2	2	3	3	3
	4	1	1	1	1	1	1	1	1	1	2	2	2	2	2	3	3	3
	5	1	1	1	1	1	1	1	1	1	1	2	2	2	2	2	3	3
	6	1	1	1	1	1	1	1	1	1	1	1	2	2	2	2	2	2
	7	1	1	1	1	1	1	1	1	1	1	1	1	2	2	2	2	2
	8	1	1	1	1	1	1	1	1	1	1	1	1	1	1	2	2	2
	9	1	1	1	1	1	1	1	1	1	1	1	1	1	1	1	2	2
	10	1	1	1	1	1	1	1	1	1	1	1	1	1	1	1	1	1
	11	1	1	1	1	1	1	1	1	1	1	1	1	1	1	1	1	1
	12	1	1	1	1	1	1	1	1	1	1	1	1	1	1	1	1	1
	13	1	1	1	1	1	1	1	1	1	1	1	1	1	1	1	1	1
	14	1	1	1	1	1	1	1	1	1	1	1	1	1	1	1	1	1

East/West orientation

		Vent height (mm)																
		2000	2100	2200	2300	2400	2500	2600	2700	2800	2900	3000	3100	3200	3300	3400	3500	3600
Colour range	1	1	1	1	1	1	1	2	2	2	2	3	3	3	3	3	3	3
	2	1	1	1	1	1	1	2	2	2	2	3	3	3	3	3	3	3
	3	1	1	1	1	1	1	2	2	2	2	2	3	3	3	3	3	3
	4	1	1	1	1	1	1	1	2	2	2	2	2	3	3	3	3	3
	5	1	1	1	1	1	1	1	1	2	2	2	2	2	3	3	3	3
	6	1	1	1	1	1	1	1	1	1	2	2	2	2	2	3	3	3
	7	1	1	1	1	1	1	1	1	1	1	2	2	2	2	2	3	3
	8	1	1	1	1	1	1	1	1	1	1	1	2	2	2	2	2	2
	9	1	1	1	1	1	1	1	1	1	1	1	1	1	2	2	2	2
	10	1	1	1	1	1	1	1	1	1	1	1	1	1	1	1	2	2
	11	1	1	1	1	1	1	1	1	1	1	1	1	1	1	1	1	1
	12	1	1	1	1	1	1	1	1	1	1	1	1	1	1	1	1	1
	13	1	1	1	1	1	1	1	1	1	1	1	1	1	1	1	1	1
	14	1	1	1	1	1	1	1	1	1	1	1	1	1	1	1	1	1

- 1 406.0340
- 2 406.0340 + 406.0099
- 3 406.0340 + 406.0094

⊘ Avoiding direct solar radiation is recommended

Please advise the chapter ‘Solutions’ to get all the details of each measure.

The deflection of the profile is due to the rapid heating by solar radiation and is temporary. It will occur at specific times of specific days of the year. The charts are formed by taking into account the maximum possible deflection that can occur when subjected to the maximum solar radiation possible and the specific external temperature. A project related calculation can be requested in order to evaluate the functionality of the element.

Standard insulation variant – Lock side – Average external summer temperature = 35°C

**South orientation**

		Vent height (mm)																
		2000	2100	2200	2300	2400	2500	2600	2700	2800	2900	3000	3100	3200	3300	3400	3500	3600
Colour range	1	1	1	1	1	1	1	2	2	2	2	2	3	3	3	3	-	-
	2	1	1	1	1	1	1	1	2	2	2	2	3	3	3	3	3	-
	3	1	1	1	1	1	1	1	1	2	2	2	2	3	3	3	3	-
	4	1	1	1	1	1	1	1	1	2	2	2	2	3	3	3	3	-
	5	1	1	1	1	1	1	1	1	1	2	2	2	2	3	3	3	3
	6	1	1	1	1	1	1	1	1	1	1	2	2	2	2	3	3	3
	7	1	1	1	1	1	1	1	1	1	1	1	2	2	2	2	3	3
	8	1	1	1	1	1	1	1	1	1	1	1	1	2	2	2	2	2
	9	1	1	1	1	1	1	1	1	1	1	1	1	2	2	2	2	2
	10	1	1	1	1	1	1	1	1	1	1	1	1	1	2	2	2	2
	11	1	1	1	1	1	1	1	1	1	1	1	1	1	1	2	2	2
	12	1	1	1	1	1	1	1	1	1	1	1	1	1	1	1	1	2
	13	1	1	1	1	1	1	1	1	1	1	1	1	1	1	1	1	1
	14	1	1	1	1	1	1	1	1	1	1	1	1	1	1	1	1	1

**East/West orientation**

		Vent height (mm)																
		2000	2100	2200	2300	2400	2500	2600	2700	2800	2900	3000	3100	3200	3300	3400	3500	3600
Colour range	1	1	1	1	1	1	2	2	2	2	3	3	3	3	-	-	-	-
	2	1	1	1	1	1	2	2	2	2	3	3	3	3	-	-	-	-
	3	1	1	1	1	1	1	2	2	2	2	3	3	3	3	-	-	-
	4	1	1	1	1	1	1	2	2	2	2	2	3	3	3	3	-	-
	5	1	1	1	1	1	1	1	2	2	2	2	3	3	3	3	3	-
	6	1	1	1	1	1	1	1	1	2	2	2	2	3	3	3	3	-
	7	1	1	1	1	1	1	1	1	1	2	2	2	2	3	3	3	3
	8	1	1	1	1	1	1	1	1	1	1	2	2	2	2	3	3	3
	9	1	1	1	1	1	1	1	1	1	1	1	2	2	2	2	3	3
	10	1	1	1	1	1	1	1	1	1	1	1	1	2	2	2	2	2
	11	1	1	1	1	1	1	1	1	1	1	1	1	1	2	2	2	2
	12	1	1	1	1	1	1	1	1	1	1	1	1	1	1	2	2	2
	13	1	1	1	1	1	1	1	1	1	1	1	1	1	1	1	1	2
	14	1	1	1	1	1	1	1	1	1	1	1	1	1	1	1	1	1

- 1 406.0340
- 2 406.0340 + 406.0099
- 3 406.0340 + 406.0094

- Avoiding direct solar radiation is recommended

Please advise the chapter 'Solutions' to get all the details of each measure.

The deflection of the profile is due to the rapid heating by solar radiation and is temporary. It will occur at specific times of specific days of the year. The charts are formed by taking into account the maximum possible deflection that can occur when subjected to the maximum solar radiation possible and the specific external temperature. A project related calculation can be requested in order to evaluate the functionality of the element.

HI insulation variant – Lock side – Average external summer temperature = 25°C

South orientation

		Vent height (mm)																
		2000	2100	2200	2300	2400	2500	2600	2700	2800	2900	3000	3100	3200	3300	3400	3500	3600
Colour range	1	1	1	1	1	1	1	2	2	2	2	3	3	3	3	3	3	
	2	1	1	1	1	1	1	1	2	2	2	2	3	3	3	3	3	
	3	1	1	1	1	1	1	1	1	2	2	2	2	3	3	3	3	
	4	1	1	1	1	1	1	1	1	2	2	2	2	3	3	3	3	
	5	1	1	1	1	1	1	1	1	1	2	2	2	2	2	3	3	
	6	1	1	1	1	1	1	1	1	1	1	2	2	2	2	2	3	
	7	1	1	1	1	1	1	1	1	1	1	1	2	2	2	2	2	
	8	1	1	1	1	1	1	1	1	1	1	1	1	1	2	2	2	
	9	1	1	1	1	1	1	1	1	1	1	1	1	1	1	2	2	
	10	1	1	1	1	1	1	1	1	1	1	1	1	1	1	1	1	
	11	1	1	1	1	1	1	1	1	1	1	1	1	1	1	1	1	
	12	1	1	1	1	1	1	1	1	1	1	1	1	1	1	1	1	
	13	1	1	1	1	1	1	1	1	1	1	1	1	1	1	1	1	
	14	1	1	1	1	1	1	1	1	1	1	1	1	1	1	1	1	

East/West orientation

		Vent height (mm)																
		2000	2100	2200	2300	2400	2500	2600	2700	2800	2900	3000	3100	3200	3300	3400	3500	3600
Colour range	1	1	1	1	1	2	2	2	2	3	3	3	3	3	3	3	3	
	2	1	1	1	1	2	2	2	2	2	3	3	3	3	3	3	3	
	3	1	1	1	1	1	2	2	2	2	3	3	3	3	3	3	3	
	4	1	1	1	1	1	1	2	2	2	2	3	3	3	3	3	3	
	5	1	1	1	1	1	1	1	2	2	2	2	3	3	3	3	3	
	6	1	1	1	1	1	1	1	1	2	2	2	2	3	3	3	3	
	7	1	1	1	1	1	1	1	1	1	2	2	2	2	2	3	3	
	8	1	1	1	1	1	1	1	1	1	1	2	2	2	2	2	3	
	9	1	1	1	1	1	1	1	1	1	1	1	2	2	2	2	2	
	10	1	1	1	1	1	1	1	1	1	1	1	1	1	2	2	2	
	11	1	1	1	1	1	1	1	1	1	1	1	1	1	1	1	2	
	12	1	1	1	1	1	1	1	1	1	1	1	1	1	1	1	1	
	13	1	1	1	1	1	1	1	1	1	1	1	1	1	1	1	1	
	14	1	1	1	1	1	1	1	1	1	1	1	1	1	1	1	1	

- 1 406.0340
- 2 406.0340 + 406.0099
- 3 406.0340 + 406.0094

- Avoiding direct solar radiation is recommended

Please advise the chapter 'Solutions' to get all the details of each measure.

The deflection of the profile is due to the rapid heating by solar radiation and is temporary. It will occur at specific times of specific days of the year. The charts are formed by taking into account the maximum possible deflection that can occur when subjected to the maximum solar radiation possible and the specific external temperature. A project related calculation can be requested in order to evaluate the functionality of the element.

**HI insulation variant – Lock side – Average external summer temperature = 35°C**

**South orientation**

		Vent height (mm)																
		2000	2100	2200	2300	2400	2500	2600	2700	2800	2900	3000	3100	3200	3300	3400	3500	3600
Colour range	1	1	1	1	1	1	2	2	2	2	3	3	3	3	3	3	-	-
	2	1	1	1	1	1	1	2	2	2	2	3	3	3	3	3	3	-
	3	1	1	1	1	1	1	2	2	2	2	2	3	3	3	3	3	3
	4	1	1	1	1	1	1	2	2	2	2	2	3	3	3	3	3	3
	5	1	1	1	1	1	1	1	2	2	2	2	2	3	3	3	3	3
	6	1	1	1	1	1	1	1	1	2	2	2	2	2	3	3	3	3
	7	1	1	1	1	1	1	1	1	1	2	2	2	2	2	3	3	3
	8	1	1	1	1	1	1	1	1	1	1	2	2	2	2	2	3	3
	9	1	1	1	1	1	1	1	1	1	1	2	2	2	2	2	3	3
	10	1	1	1	1	1	1	1	1	1	1	1	1	1	2	2	2	2
	11	1	1	1	1	1	1	1	1	1	1	1	1	1	1	2	2	2
	12	1	1	1	1	1	1	1	1	1	1	1	1	1	1	1	1	2
	13	1	1	1	1	1	1	1	1	1	1	1	1	1	1	1	1	2
	14	1	1	1	1	1	1	1	1	1	1	1	1	1	1	1	1	1

**East/West orientation**

		Vent height (mm)																
		2000	2100	2200	2300	2400	2500	2600	2700	2800	2900	3000	3100	3200	3300	3400	3500	3600
Colour range	1	1	1	1	2	2	2	2	2	3	3	3	3	3	3	-	-	-
	2	1	1	1	1	2	2	2	2	3	3	3	3	3	-	-	-	-
	3	1	1	1	1	2	2	2	2	2	3	3	3	3	3	-	-	-
	4	1	1	1	1	1	2	2	2	2	3	3	3	3	3	3	-	-
	5	1	1	1	1	1	1	2	2	2	2	3	3	3	3	3	3	-
	6	1	1	1	1	1	1	2	2	2	2	2	3	3	3	3	3	3
	7	1	1	1	1	1	1	1	2	2	2	2	2	3	3	3	3	3
	8	1	1	1	1	1	1	1	1	2	2	2	2	2	3	3	3	3
	9	1	1	1	1	1	1	1	1	1	2	2	2	2	2	3	3	3
	10	1	1	1	1	1	1	1	1	1	1	2	2	2	2	2	3	3
	11	1	1	1	1	1	1	1	1	1	1	1	2	2	2	2	2	2
	12	1	1	1	1	1	1	1	1	1	1	1	1	1	2	2	2	2
	13	1	1	1	1	1	1	1	1	1	1	1	1	1	1	1	2	2
	14	1	1	1	1	1	1	1	1	1	1	1	1	1	1	1	1	2

- 1 406.0340
- 2 406.0340 + 406.0099
- 3 406.0340 + 406.0094

- Avoiding direct solar radiation is recommended

Please advise the chapter ‘Solutions’ to get all the details of each measure.

The deflection of the profile is due to the rapid heating by solar radiation and is temporary. It will occur at specific times of specific days of the year. The charts are formed by taking into account the maximum possible deflection that can occur when subjected to the maximum solar radiation possible and the specific external temperature. A project related calculation can be requested in order to evaluate the functionality of the element.

Standard/HI insulation variant – Meeting section – Average external summer temperature = 25 to 35°C

Colour range	Vent height (mm)																
	2000	2100	2200	2300	2400	2500	2600	2700	2800	2900	3000	3100	3200	3300	3400	3500	3600
1	1	1	1	1	1	1	1	1	1	1	1	1	1	1	1	2	2
2	1	1	1	1	1	1	1	1	1	1	1	1	1	1	1	1	2
3	1	1	1	1	1	1	1	1	1	1	1	1	1	1	1	1	1
4	1	1	1	1	1	1	1	1	1	1	1	1	1	1	1	1	1
5	1	1	1	1	1	1	1	1	1	1	1	1	1	1	1	1	1
6	1	1	1	1	1	1	1	1	1	1	1	1	1	1	1	1	1
7	1	1	1	1	1	1	1	1	1	1	1	1	1	1	1	1	1
8	1	1	1	1	1	1	1	1	1	1	1	1	1	1	1	1	1
9	1	1	1	1	1	1	1	1	1	1	1	1	1	1	1	1	1
10	1	1	1	1	1	1	1	1	1	1	1	1	1	1	1	1	1
11	1	1	1	1	1	1	1	1	1	1	1	1	1	1	1	1	1
12	1	1	1	1	1	1	1	1	1	1	1	1	1	1	1	1	1
13	1	1	1	1	1	1	1	1	1	1	1	1	1	1	1	1	1
14	1	1	1	1	1	1	1	1	1	1	1	1	1	1	1	1	1

B

- 1 406.0335 / 406.0330
- 2 406.0335+406.0092 / 406.0335+406.0094 / 406.0335+406.0096 / 406.0330+406.0092 / 406.0330+406.0094

Please advise the chapter ‘Solutions’ to get all the details of each measure.

The deflection of the profile is due to the rapid heating by solar radiation and is temporary. It will occur at specific times of specific days of the year. The charts are formed by taking into account the maximum possible deflection that can occur when subjected to the maximum solar radiation possible and the specific external temperature. A project related calculation can be requested in order to evaluate the functionality of the element.

# BIMETALLEFFEKT AUF SCHIEBETÜREN

## I. Beschreibung des Bimetall-Effekts

Der Bimetall-Effekt tritt an Schiebetüren auf, wenn ein Temperaturunterschied zwischen der inneren und äußeren Halbschale eines thermisch unterbrochenen Profils besteht. Das ist der Fall bei warmen Außenumgebungen und extrem kalten Umgebungen.

Bei Schiebetüren wurden zwei Arten von bimetallischer Biegung beobachtet.

- Erwärmung des Hohlraums: Profile der Wechsellage biegen sich beim Öffnen des Flügels aufeinander zu.
- Direkte Sonnenstrahlung: Biegung der Profile in eine Richtung

### I.1 Erwärmung des Hohlraums

Wenn eine Schiebetür geöffnet wird, gibt es einen Hohlraum zwischen den beiden Glasscheiben. Wird dieser Hohlraum von der Sonne erwärmt und haben die Profile eine helle Farbe (Gruppe 7–14 siehe **Error! Reference source not found.**), biegen sich die Profile der Wechsellagen aufeinander zu. Wenn die Tür geschlossen wird, können die PVC-Profile sich gegenseitig beschädigen.

### I.2 Direkte Sonnenstrahlung

Das Flügelprofil auf der Schließseite (offene und geschlossene Position) und die Profile der Wechsellage (geschlossene Position) verbiegen sich vorübergehend, wenn sie durch Sonnenstrahlung erwärmt werden. Einen wesentlichen Einfluss haben die Farbe des Profils, die Positionen und Ausrichtung der Schiebetür. Die Sonnenstrahlung ist an der Ost- und Westfassade direkter, da die Profile senkrecht sind und die Sonne bei diesen Ausrichtungen tief steht.



Abbildung 1: Sonneneinstrahlung am Sommertag

Die tatsächliche Einstrahlung auf die Profile wird durch die tatsächlichen Gegebenheiten (z.B. umliegende Gebäude, Sonnenschutz, Bäume, Bewölkung, atmosphärische Bedingungen usw.) beeinflusst, die zusätzliche Abschattung bewirken können, und sollte in Abhängigkeit vom Projekt bewertet werden.

**I.2.1 Strahlung: farbabhängig**

Die Farbe des Profils beeinflusst die Temperatur der äußeren Skala und wird durch die Wärmeabsorption dieser Farbe bestimmt. Je dunkler die Farbe (Gruppe 1), desto kritischer ist sie. Die verschiedenen Farben wurden nach ihrem Verhalten gruppiert. Folgende Farbgruppen (RAL) verhalten sich ähnlich, wenn sie Sonnenstrahlung ausgesetzt sind:

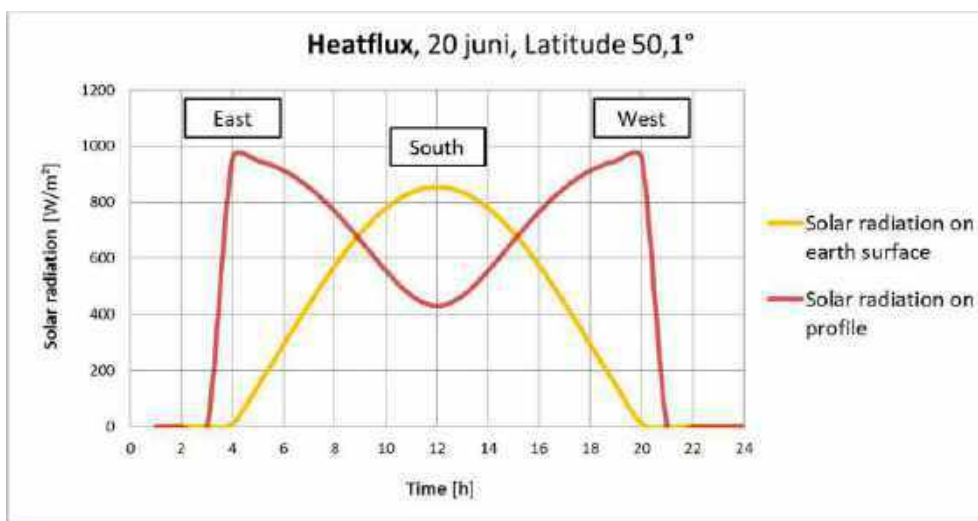
1	5004 8022 9005	<i>Wo RAL 9005 – Tiefschwarz</i>
2	3004 3005 3007 4007 5003 5008 5011 5013 5020 5022 6005 6007 6008 6009 6012 6022 7021 8014 8016 8017 8019 9004 9011 9017	
3	3003 3009 3011 5000 5001 5002 5010 6004 6006 6014 6015 6020 7016 7022 7024 7026 8011 8012 8015 8028	
4	3000 3001 3002 3013 3027 4002 4006 5005 5009 5017 5019 6002 6003 6016 6026 6028 7009 7010 7011 7013 7015 7043 8002 8003 8007 8008 8024	
5	2002 3016 3020 3031 4008 5007 5021 5023 6000 6001 6010 6025 6029 7006 7008 7012 7031 7039 8004 8025	
6	2001 3017 3018 4001 4005 4010 5014 5015 6011 6013 6017 6024 6032 7003 7005 8000 8001 8023	
7	1027 2004 2009 2010 2012 3022 4003 5012 5018 6018 6033 7000 7002 7023 7033 7034 7037 7046	
8	1005 1011 1019 1020 1024 2000 2008 2011 3012 3014 4009 5024 6021 7001 7030 7036 7042 7045	
9	1006 1007 2003 6034 7004 7040	
10	1001 1002 1012 1028 1033 1034 3015 6027 7032 7038 7044	
11	1000 1003 1017 1021 1023 6019 7035	
12	1014 1018 7047 9018	
13	1013 1015 1016	
14	9003 9010 9016	<i>Wo RAL 9016 – Verkehrsweiß</i>

Tabelle 1: Gruppierung der verschiedenen Farben

**II. Erläuterung der Diagramme**

Der Bimetall-Effekt wird durch **Sonnenstrahlung** auf die Profiloberfläche, die **Außenlufttemperaturen** und die **Ausrichtung** der Schiebetür beeinflusst.

Nachfolgend finden Sie Diagramme für nach Osten/Westen ausgerichtete Fassaden und nach Süden ausgerichtete Fassaden sowie für zwei verschiedene Außentemperaturen. Bitte wählen Sie die Situation, die Ihrem Einsatzort am ähnlichsten ist.

**AUSWAHLSCHRITTE:**

- a. Isolationsvariante wählen (Standard oder HI)
- b. Diagramme verfügbar für schließseitige Profile auf Basis der Ausrichtung und Temperatur
- c. Wählen Sie die zutreffendste Variante für die durchschnittliche Außentemperatur am Einsatzort in den Sommermonaten
- d. Ausrichtung der Fassade wählen
- e. Feststellen, welche Maßnahmen getroffen werden müssen, um die vorübergehende Auslenkung aufgrund des Bimetall-Effekts zu minimieren
- f. Diagramm für Profile von Wechselsektionen verfügbar (ein Diagramm gilt für alle Ausrichtungen und für durchschnittliche Außentemperaturen im Sommer bis  $T_{ext}=35\text{ °C}$ )
- g. Siehe das Kapitel „Lösungen“ für Einzelheiten zu den erforderlichen Maßnahmen

Für durchschnittliche Außentemperaturen bis  $25\text{ °C}$  in den Sommermonaten wählen Sie bitte die Diagramme mit  $T_{ext} = 25\text{ °C}$ . Für durchschnittliche Außentemperaturen zwischen  $26\text{ °C}$ – $35\text{ °C}$  in den Sommermonaten wählen Sie bitte die Diagramme mit  $T_{ext} = 35\text{ °C}$ . Für höhere Außentemperaturen ist eine projektbezogene Berechnung erforderlich.

## III. Lösungen

### III.1 Schließseite

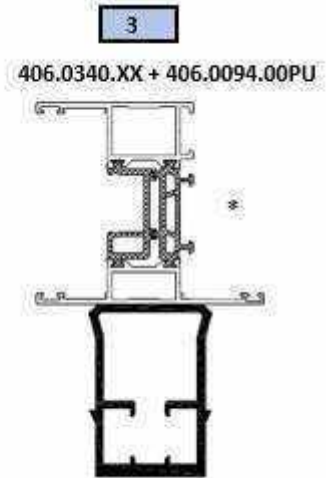
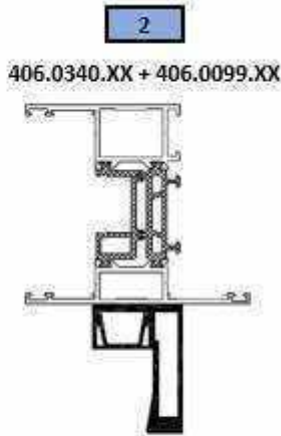

Direkte Sonnenstrahlung auf die Profile wird nicht empfohlen.\*\*

Reynaers hat Sonnenschutzsysteme in seinem Sortiment (BS 30, BS 100).



### III.2 Wechselprofil

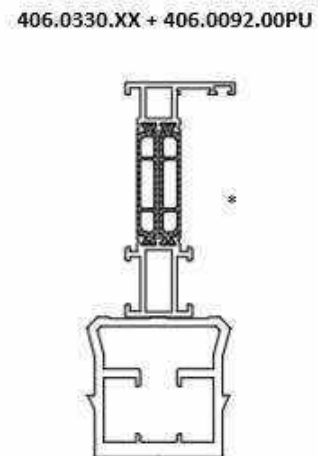
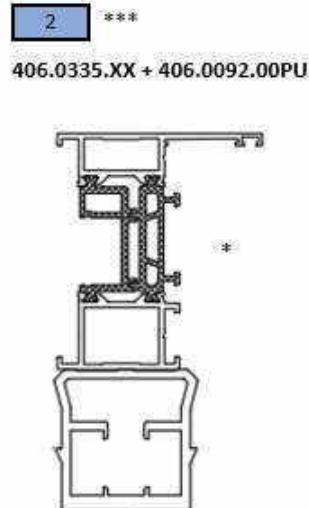
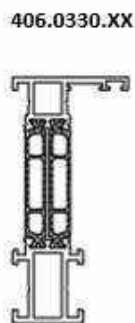

- \* Jede Verstärkung, die den Ix-Wert dieser Kombination erreicht, kann verwendet werden.
- \*\* Zur Beurteilung der Funktionalität des Elements kann eine projektbezogene Berechnung angefordert werden.
- \*\*\* Für das Wechselprofil sollte die Verstärkung auf dem äußeren Profil angebracht werden.

Isolationsvariante Standard – Schließseite – Durchschnittliche Außentemperatur im Sommer = 25°C

Süd-Ausrichtung

		Flügelhöhe (mm)																
		2000	2100	2200	2300	2400	2500	2600	2700	2800	2900	3000	3100	3200	3300	3400	3500	3600
Farbreite	1	1	1	1	1	1	1	1	1	2	2	2	2	2	3	3	3	3
	2	1	1	1	1	1	1	1	1	1	2	2	2	2	2	3	3	3
	3	1	1	1	1	1	1	1	1	1	1	2	2	2	2	2	3	3
	4	1	1	1	1	1	1	1	1	1	1	2	2	2	2	2	3	3
	5	1	1	1	1	1	1	1	1	1	1	1	2	2	2	2	2	3
	6	1	1	1	1	1	1	1	1	1	1	1	1	2	2	2	2	2
	7	1	1	1	1	1	1	1	1	1	1	1	1	1	1	2	2	2
	8	1	1	1	1	1	1	1	1	1	1	1	1	1	1	1	2	2
	9	1	1	1	1	1	1	1	1	1	1	1	1	1	1	1	2	2
	10	1	1	1	1	1	1	1	1	1	1	1	1	1	1	1	1	1
	11	1	1	1	1	1	1	1	1	1	1	1	1	1	1	1	1	1
	12	1	1	1	1	1	1	1	1	1	1	1	1	1	1	1	1	1
	13	1	1	1	1	1	1	1	1	1	1	1	1	1	1	1	1	1
	14	1	1	1	1	1	1	1	1	1	1	1	1	1	1	1	1	1

Ost/West-Ausrichtung

		Flügelhöhe (mm)																
		2000	2100	2200	2300	2400	2500	2600	2700	2800	2900	3000	3100	3200	3300	3400	3500	3600
Farbreite	1	1	1	1	1	1	1	2	2	2	2	3	3	3	3	3	3	3
	2	1	1	1	1	1	1	1	2	2	2	2	3	3	3	3	3	3
	3	1	1	1	1	1	1	1	2	2	2	2	2	3	3	3	3	3
	4	1	1	1	1	1	1	1	1	2	2	2	2	2	3	3	3	3
	5	1	1	1	1	1	1	1	1	1	2	2	2	2	2	3	3	3
	6	1	1	1	1	1	1	1	1	1	1	2	2	2	2	2	3	3
	7	1	1	1	1	1	1	1	1	1	1	1	2	2	2	2	2	3
	8	1	1	1	1	1	1	1	1	1	1	1	1	2	2	2	2	2
	9	1	1	1	1	1	1	1	1	1	1	1	1	1	1	2	2	2
	10	1	1	1	1	1	1	1	1	1	1	1	1	1	1	1	2	2
	11	1	1	1	1	1	1	1	1	1	1	1	1	1	1	1	1	1
	12	1	1	1	1	1	1	1	1	1	1	1	1	1	1	1	1	1
	13	1	1	1	1	1	1	1	1	1	1	1	1	1	1	1	1	1
	14	1	1	1	1	1	1	1	1	1	1	1	1	1	1	1	1	1

- 1 406.0340
- 2 406.0340 + 406.0099
- 3 406.0340 + 406.0094

- Vermeiden von direkter Sonneneinstrahlung wird empfohlen

Bitte beachten Sie das Kapitel „Lösungen“, um alle Einzelheiten zu jeder Maßnahme zu erfahren.

Die Auslenkung des Profils ist auf die schnelle Erwärmung durch Sonnenstrahlung zurückzuführen und ist vorübergehender Art. Sie wird zu bestimmten Zeiten an bestimmten Tagen des Jahres auftreten. Die Diagramme wurden unter Berücksichtigung der maximal möglichen Auslenkung ermittelt, die auftreten kann, wenn das Profil der maximal möglichen Sonneneinstrahlung und der spezifischen Außentemperatur ausgesetzt ist. Eine projektbezogene Berechnung zum Beurteilen der Funktionalität des Elements kann angefordert werden.

**Isolationsvariante Standard – Schließseite – Durchschnittliche Außentemperatur im Sommer = 35°C**

**Süd-Ausrichtung**

		Flügelhöhe (mm)																
		2000	2100	2200	2300	2400	2500	2600	2700	2800	2900	3000	3100	3200	3300	3400	3500	3600
Farbreihe	1	1	1	1	1	1	1	2	2	2	2	2	3	3	3	3	-	-
	2	1	1	1	1	1	1	1	2	2	2	2	3	3	3	3	3	-
	3	1	1	1	1	1	1	1	1	2	2	2	2	3	3	3	3	-
	4	1	1	1	1	1	1	1	1	2	2	2	2	3	3	3	3	-
	5	1	1	1	1	1	1	1	1	1	2	2	2	2	3	3	3	3
	6	1	1	1	1	1	1	1	1	1	1	2	2	2	2	3	3	3
	7	1	1	1	1	1	1	1	1	1	1	1	2	2	2	2	3	3
	8	1	1	1	1	1	1	1	1	1	1	1	1	2	2	2	2	2
	9	1	1	1	1	1	1	1	1	1	1	1	1	2	2	2	2	2
	10	1	1	1	1	1	1	1	1	1	1	1	1	1	1	2	2	2
	11	1	1	1	1	1	1	1	1	1	1	1	1	1	1	2	2	2
	12	1	1	1	1	1	1	1	1	1	1	1	1	1	1	1	1	2
	13	1	1	1	1	1	1	1	1	1	1	1	1	1	1	1	1	1
	14	1	1	1	1	1	1	1	1	1	1	1	1	1	1	1	1	1

**Ost/West-Ausrichtung**

		Flügelhöhe (mm)																
		2000	2100	2200	2300	2400	2500	2600	2700	2800	2900	3000	3100	3200	3300	3400	3500	3600
Farbreihe	1	1	1	1	1	1	2	2	2	2	3	3	3	-	-	-	-	-
	2	1	1	1	1	1	2	2	2	2	3	3	3	-	-	-	-	-
	3	1	1	1	1	1	1	2	2	2	2	3	3	3	3	-	-	-
	4	1	1	1	1	1	1	2	2	2	2	2	3	3	3	3	-	-
	5	1	1	1	1	1	1	1	2	2	2	2	3	3	3	3	3	-
	6	1	1	1	1	1	1	1	1	2	2	2	2	3	3	3	3	-
	7	1	1	1	1	1	1	1	1	1	2	2	2	2	3	3	3	3
	8	1	1	1	1	1	1	1	1	1	1	2	2	2	2	3	3	3
	9	1	1	1	1	1	1	1	1	1	1	1	2	2	2	2	3	3
	10	1	1	1	1	1	1	1	1	1	1	1	1	2	2	2	2	2
	11	1	1	1	1	1	1	1	1	1	1	1	1	1	2	2	2	2
	12	1	1	1	1	1	1	1	1	1	1	1	1	1	1	2	2	2
	13	1	1	1	1	1	1	1	1	1	1	1	1	1	1	1	1	2
	14	1	1	1	1	1	1	1	1	1	1	1	1	1	1	1	1	1

- 1 406.0340
- 2 406.0340 + 406.0099
- 3 406.0340 + 406.0094

- Vermeiden von direkter Sonneneinstrahlung wird empfohlen

**Bitte beachten Sie das Kapitel „Lösungen“, um alle Einzelheiten zu jeder Maßnahme zu erfahren.**

Die Auslenkung des Profils ist auf die schnelle Erwärmung durch Sonnenstrahlung zurückzuführen und ist vorübergehender Art. Sie wird zu bestimmten Zeiten an bestimmten Tagen des Jahres auftreten. Die Diagramme wurden unter Berücksichtigung der maximal möglichen Auslenkung ermittelt, die auftreten kann, wenn das Profil der maximal möglichen Sonneneinstrahlung und der spezifischen Außentemperatur ausgesetzt ist. Eine projektbezogene Berechnung zum Beurteilen der Funktionalität des Elements kann angefordert werden.

Isolationsvariante HI – Schließseite – Durchschnittliche Außentemperatur im Sommer = 25°C

**Süd-Ausrichtung**

		Flügelhöhe (mm)																
		2000	2100	2200	2300	2400	2500	2600	2700	2800	2900	3000	3100	3200	3300	3400	3500	3600
Farbreite	1	1	1	1	1	1	1	1	2	2	2	2	3	3	3	3	3	3
	2	1	1	1	1	1	1	1	1	2	2	2	2	3	3	3	3	3
	3	1	1	1	1	1	1	1	1	1	2	2	2	2	3	3	3	3
	4	1	1	1	1	1	1	1	1	1	1	2	2	2	2	3	3	3
	5	1	1	1	1	1	1	1	1	1	1	1	2	2	2	2	3	3
	6	1	1	1	1	1	1	1	1	1	1	1	1	2	2	2	2	3
	7	1	1	1	1	1	1	1	1	1	1	1	1	1	2	2	2	2
	8	1	1	1	1	1	1	1	1	1	1	1	1	1	1	2	2	2
	9	1	1	1	1	1	1	1	1	1	1	1	1	1	1	1	2	2
	10	1	1	1	1	1	1	1	1	1	1	1	1	1	1	1	1	1
	11	1	1	1	1	1	1	1	1	1	1	1	1	1	1	1	1	1
	12	1	1	1	1	1	1	1	1	1	1	1	1	1	1	1	1	1
	13	1	1	1	1	1	1	1	1	1	1	1	1	1	1	1	1	1
	14	1	1	1	1	1	1	1	1	1	1	1	1	1	1	1	1	1

**Ost/West-Ausrichtung**

		Flügelhöhe (mm)																
		2000	2100	2200	2300	2400	2500	2600	2700	2800	2900	3000	3100	3200	3300	3400	3500	3600
Farbreite	1	1	1	1	1	1	2	2	2	2	3	3	3	3	3	3	3	3
	2	1	1	1	1	1	2	2	2	2	2	3	3	3	3	3	3	3
	3	1	1	1	1	1	1	2	2	2	2	3	3	3	3	3	3	3
	4	1	1	1	1	1	1	1	2	2	2	2	3	3	3	3	3	3
	5	1	1	1	1	1	1	1	1	2	2	2	2	3	3	3	3	3
	6	1	1	1	1	1	1	1	1	1	1	2	2	2	2	3	3	3
	7	1	1	1	1	1	1	1	1	1	1	1	2	2	2	2	3	3
	8	1	1	1	1	1	1	1	1	1	1	1	1	2	2	2	2	3
	9	1	1	1	1	1	1	1	1	1	1	1	1	1	2	2	2	2
	10	1	1	1	1	1	1	1	1	1	1	1	1	1	1	2	2	2
	11	1	1	1	1	1	1	1	1	1	1	1	1	1	1	1	1	2
	12	1	1	1	1	1	1	1	1	1	1	1	1	1	1	1	1	1
	13	1	1	1	1	1	1	1	1	1	1	1	1	1	1	1	1	1
	14	1	1	1	1	1	1	1	1	1	1	1	1	1	1	1	1	1

- 1 406.0340
- 2 406.0340 + 406.0099
- 3 406.0340 + 406.0094

- Vermeiden von direkter Sonneneinstrahlung wird empfohlen

Bitte beachten Sie das Kapitel „Lösungen“, um alle Einzelheiten zu jeder Maßnahme zu erfahren.

Die Auslenkung des Profils ist auf die schnelle Erwärmung durch Sonnenstrahlung zurückzuführen und ist vorübergehender Art. Sie wird zu bestimmten Zeiten an bestimmten Tagen des Jahres auftreten. Die Diagramme wurden unter Berücksichtigung der maximal möglichen Auslenkung ermittelt, die auftreten kann, wenn das Profil der maximal möglichen Sonneneinstrahlung und der spezifischen Außentemperatur ausgesetzt ist. Eine projektbezogene Berechnung zum Beurteilen der Funktionalität des Elements kann angefordert werden.

**Isolationsvariante HI – Schließseite – Durchschnittliche Außentemperatur im Sommer = 35°C**

**Süd-Ausrichtung**

Farbreihe	Flügelhöhe (mm)																
	2000	2100	2200	2300	2400	2500	2600	2700	2800	2900	3000	3100	3200	3300	3400	3500	3600
1	1	1	1	1	1	2	2	2	2	3	3	3	3	3	3	3	3
2	1	1	1	1	1	1	2	2	2	2	3	3	3	3	3	3	3
3	1	1	1	1	1	1	2	2	2	2	2	3	3	3	3	3	3
4	1	1	1	1	1	1	2	2	2	2	2	3	3	3	3	3	3
5	1	1	1	1	1	1	1	2	2	2	2	2	3	3	3	3	3
6	1	1	1	1	1	1	1	1	2	2	2	2	2	3	3	3	3
7	1	1	1	1	1	1	1	1	1	2	2	2	2	2	3	3	3
8	1	1	1	1	1	1	1	1	1	1	2	2	2	2	2	3	3
9	1	1	1	1	1	1	1	1	1	1	2	2	2	2	2	3	3
10	1	1	1	1	1	1	1	1	1	1	1	1	1	2	2	2	2
11	1	1	1	1	1	1	1	1	1	1	1	1	1	2	2	2	2
12	1	1	1	1	1	1	1	1	1	1	1	1	1	1	1	2	2
13	1	1	1	1	1	1	1	1	1	1	1	1	1	1	1	1	2
14	1	1	1	1	1	1	1	1	1	1	1	1	1	1	1	1	1

**Ost/West-Ausrichtung**

Farbreihe	Flügelhöhe (mm)																
	2000	2100	2200	2300	2400	2500	2600	2700	2800	2900	3000	3100	3200	3300	3400	3500	3600
1	1	1	1	2	2	2	2	2	3	3	3	3	3	-	-	-	-
2	1	1	1	1	2	2	2	2	3	3	3	3	3	-	-	-	-
3	1	1	1	1	2	2	2	2	2	3	3	3	3	3	-	-	-
4	1	1	1	1	1	2	2	2	2	3	3	3	3	3	3	-	-
5	1	1	1	1	1	1	2	2	2	2	3	3	3	3	3	3	-
6	1	1	1	1	1	1	2	2	2	2	2	3	3	3	3	3	3
7	1	1	1	1	1	1	1	2	2	2	2	2	3	3	3	3	3
8	1	1	1	1	1	1	1	1	2	2	2	2	2	3	3	3	3
9	1	1	1	1	1	1	1	1	1	2	2	2	2	2	3	3	3
10	1	1	1	1	1	1	1	1	1	1	2	2	2	2	2	3	3
11	1	1	1	1	1	1	1	1	1	1	1	2	2	2	2	2	2
12	1	1	1	1	1	1	1	1	1	1	1	1	1	2	2	2	2
13	1	1	1	1	1	1	1	1	1	1	1	1	1	1	1	2	2
14	1	1	1	1	1	1	1	1	1	1	1	1	1	1	1	1	2

- 1 406.0340
- 2 406.0340 + 406.0099
- 3 406.0340 + 406.0094

- Vermeiden von direkter Sonneneinstrahlung wird empfohlen

**Bitte beachten Sie das Kapitel „Lösungen“, um alle Einzelheiten zu jeder Maßnahme zu erfahren.**

Die Auslenkung des Profils ist auf die schnelle Erwärmung durch Sonnenstrahlung zurückzuführen und ist vorübergehender Art. Sie wird zu bestimmten Zeiten an bestimmten Tagen des Jahres auftreten. Die Diagramme wurden unter Berücksichtigung der maximal möglichen Auslenkung ermittelt, die auftreten kann, wenn das Profil der maximal möglichen Sonneneinstrahlung und der spezifischen Außentemperatur ausgesetzt ist. Eine projektbezogene Berechnung zum Beurteilen der Funktionalität des Elements kann angefordert werden.

**Isolationsvariante Standard/Hi – Wechselprofil – Durchschnittliche Außentemperatur im Sommer = 25 zu 35°C**

		Flügelhöhe (mm)																	
		2000	2100	2200	2300	2400	2500	2600	2700	2800	2900	3000	3100	3200	3300	3400	3500	3600	
F <span>ü</span> rb <span>r</span> e <span>i</span> t <span>e</span>	1	1	1	1	1	1	1	1	1	1	1	1	1	1	1	1	2	2	
	2	1	1	1	1	1	1	1	1	1	1	1	1	1	1	1	1	1	2
	3	1	1	1	1	1	1	1	1	1	1	1	1	1	1	1	1	1	1
	4	1	1	1	1	1	1	1	1	1	1	1	1	1	1	1	1	1	1
	5	1	1	1	1	1	1	1	1	1	1	1	1	1	1	1	1	1	1
	6	1	1	1	1	1	1	1	1	1	1	1	1	1	1	1	1	1	1
	7	1	1	1	1	1	1	1	1	1	1	1	1	1	1	1	1	1	1
	8	1	1	1	1	1	1	1	1	1	1	1	1	1	1	1	1	1	1
	9	1	1	1	1	1	1	1	1	1	1	1	1	1	1	1	1	1	1
	10	1	1	1	1	1	1	1	1	1	1	1	1	1	1	1	1	1	1
	11	1	1	1	1	1	1	1	1	1	1	1	1	1	1	1	1	1	1
	12	1	1	1	1	1	1	1	1	1	1	1	1	1	1	1	1	1	1
	13	1	1	1	1	1	1	1	1	1	1	1	1	1	1	1	1	1	1
	14	1	1	1	1	1	1	1	1	1	1	1	1	1	1	1	1	1	1

- 1 406.0335 / 406.0330
- 2 406.0335+406.0092 / 406.0335+406.0094 / 406.0335+406.0096 / 406.0330+406.0092 / 406.0330+406.0094

Bitte beachten Sie das Kapitel „Lösungen“, um alle Einzelheiten zu jeder Maßnahme zu erfahren.

Die Auslenkung des Profils ist auf die schnelle Erwärmung durch Sonnenstrahlung zurückzuführen und ist vorübergehender Art. Sie wird zu bestimmten Zeiten an bestimmten Tagen des Jahres auftreten. Die Diagramme wurden unter Berücksichtigung der maximal möglichen Auslenkung ermittelt, die auftreten kann, wenn das Profil der maximal möglichen Sonneneinstrahlung und der spezifischen Außentemperatur ausgesetzt ist. Eine projektbezogene Berechnung zum Beurteilen der Funktionalität des Elements kann angefordert werden.

1



KEUZE CONFIGURATIE  
 CHOIX DE CONFIGURATION  
 CONFIGURATION SELECT  
 WAHL KONFIGURATION

CONFIGURATIE CONFIGURATION CONFIGURATION KONFIGURATION	GEWICHT (X) / GEWICHT (X) + GEWICHT (O) POIDS (X) / POIDS (X) + POIDS (O) WEIGHT (X) / WEIGHT (X) + WEIGHT (O) GEWICHTE (X) / GEWICHTE (X) + GEWICHTE (O)	 SYNC (*)	SET 1	HOOGTE HEFMOTOR HAUTEUR MOTEUR DE LEVAGE HEIGHT LIFTMOTOR HOEHE LIFTMOTOR	
				SET 2 (**) 1645≤HX<2165 2165≤HX≤2670 2905≤HX<3505 + Extention 34G.F	SET 3 2465≤HX<2905 HX≥3505 + Extention 34G.F
QX / XQ QXQ XQVQ QVQX	X<400 KG 1 SLIDE MOTOR	NO	1	1	1
XQX (BQ>2BX) XQVQX	X<400 KG 2x 1 SLIDE MOTOR	NO	2	2	2
QXXQ	X<400 KG 2x 1 SLIDE MOTOR	YES + 1x ELEMENT CONTROLLER: 062.8610.--	2 + 2x Rbus sync cable 0.5m 062.8580.--	2	2
X(X)	X<400 KG 4x 1 SLIDE MOTOR	YES + 1x ELEMENT CONTROLLER: 062.8610.--	4 + 4x Rbus sync cable 0.5m 062.8580.--	4	4
X(X)X(X)	X<400 KG 4x 1 SLIDE MOTOR	YES + 1x ELEMENT CONTROLLER: 062.8610.--	4 + 4x Rbus sync cable 0.5m 062.8580.--	4	4
XOQ	X+O<400 KG 1 SLIDE MOTOR	YES + 1x ELEMENT CONTROLLER: 062.8610.--	1 + 1x Rbus sync cable 0.5m 062.8580.--	2	2
XO(X) QOX(X)OQ	X(+O)<400 KG 2x 1 SLIDE MOTOR	YES + 1x ELEMENT CONTROLLER: 062.8610.--	2 + 2x Rbus sync cable 0.5m 062.8580.--	4	4
X(OX)X(O)X (BX>B(OX))	X(+O)<400 KG 4x 1 SLIDE MOTOR	YES + 1x ELEMENT CONTROLLER: 062.8610.--	4 + 4x Rbus sync cable 0.5m 062.8580.--	6	6

(\*) SYNC YES = WHEN THE MOVEMENT OF TWO/FOUR SLIDE MOTORS NEED TO BE SYNCHRONIZED OR A SINGLE BUTTON IS USED TO CONTROL MULTIPLE MOTORS OR VENTS.

(\*\*) HX < 2165mm additional sawing/handling needed on liftmotor

	SET ①
SLIDE MOTOR	062.7300.--
SLIDE MOTOR MOUNTING BRACKET SET	062.7301.--
SLIDE MOTOR CABLE DOCKING	062.7302.--
RETURN PULLEY	062.7303.--
SASH CONNECTION SET	062.7304.--
SCREW PLATE FOR FIXATIONS	062.7308.--

	SET ②	SET ③
LIFT MOTOR	062.7306.-- (2.6 m)	062.7307.-- (2.8 m)
LIFT MOTOR HOLE SEAL (2x black + 2x white)	062.8377.SY	062.8377.SY
POWER TRANSFER SET	062.7305.--	062.7305.--
FLAT CABLE LIFT MOTOR (TO POWER TRANSFER) L:2.2m	1x 062.8573.-- (HX>3210 2x062.8573.--)	1x 062.8573.-- (HX>3210 2x062.8573.--)
EPDM SEALING PIECE CHICAN	162.9075.04	162.9075.04
SUPPORT BUFFER (fill piece under covercap)	062.7311.--	062.7311.--

	STANDARD	MOTORIZED
MONORAIL	406.0323.XX + 406.0320.04	406.0334.XX + 406.0371.XX + 406.0372.04 + 080.9381.04
2RAIL	406.0302.XX + 406.0320.04	

MEER DETAILS BETREFFENDE ELEKTRISCHE SCHEMA'S ZIE ACCESS CONTROL  
 PLUS DE DETAILS CONCERNANT LES DIAGRAMMES ÉLECTRIQUES VOIR ACCESS CONTROL  
 MORE DETAILS REGARDING ELECTRICAL SCHEMES SEE ACCESS CONTROL  
 WEITERE DETAILS ZU ELEKTRISCHEN DIAGRAMMEN FINDEN SIE UNTER ACCESS CONTROL

<https://www.reynaers.com/en/reynaers-customer-portal-nl>  
<https://www.reynaers.com/en/reynaers-customer-portal-fr>  
<https://www.reynaers.com/en/reynaers-customer-portal-en>  
<https://www.reynaers.com/en/reynaers-customer-portal-de>

**2** KEUZE CONFIGURATIE  
 CHOIX DE CONFIGURATION  
 CONFIGURATION SELECT  
 WAHL KONFIGURATION

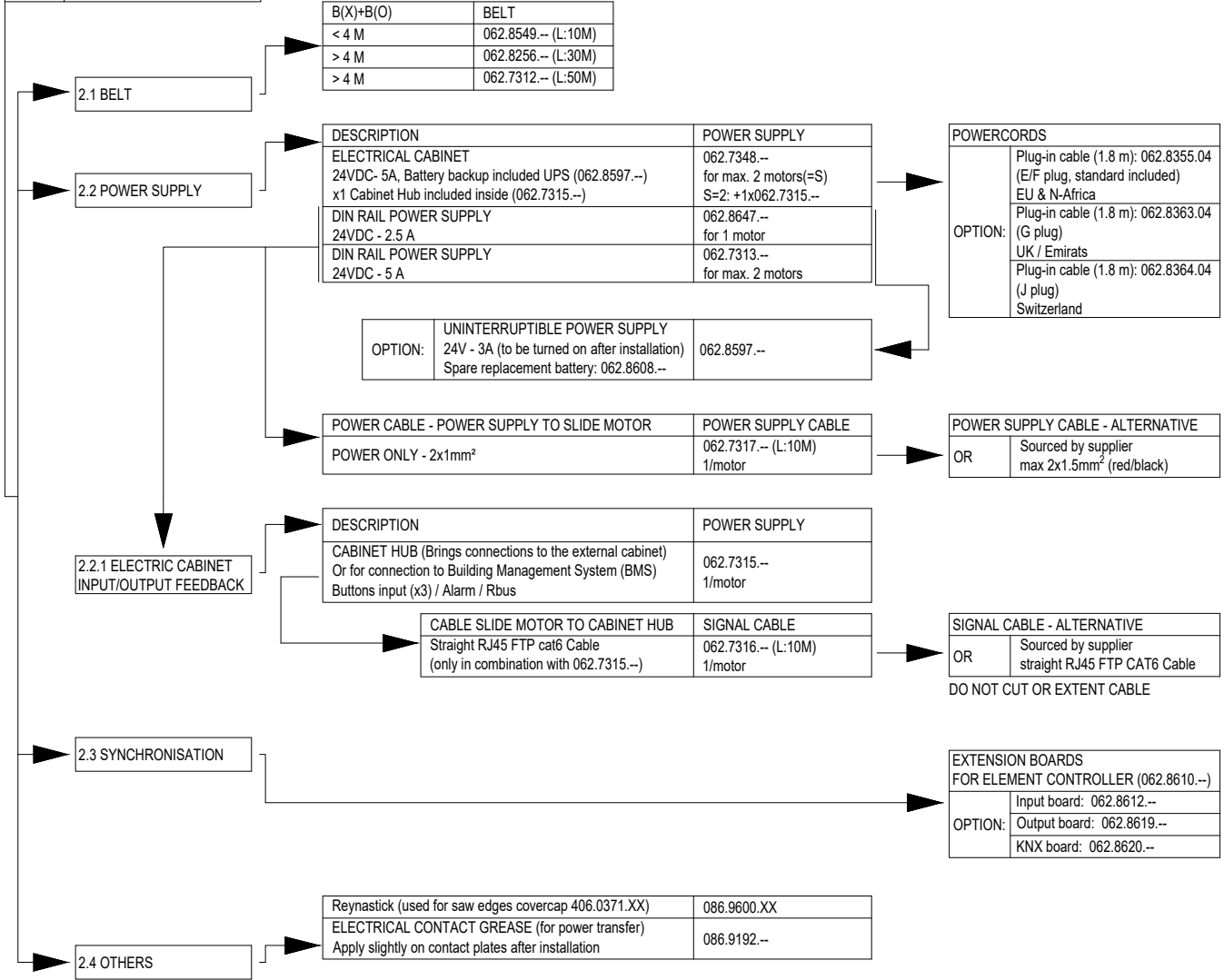

**3** KEUZE CONFIGURATIE  
 CHOIX DE CONFIGURATION  
 CONFIGURATION SELECT  
 WAHL KONFIGURATION

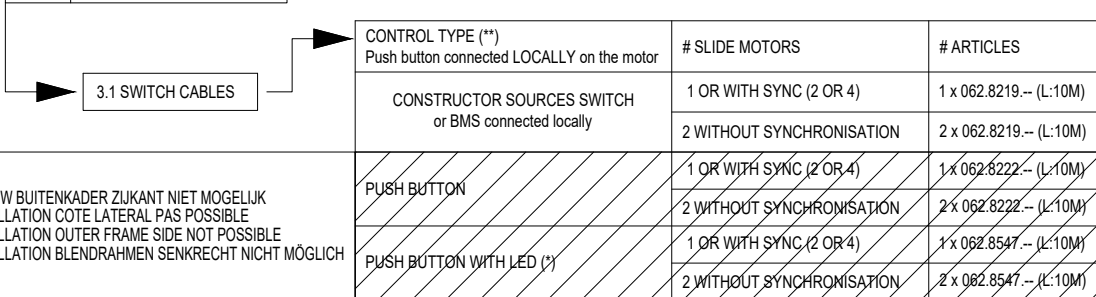

INBOUW BUITENKADER ZIJKANT NIET MOGELIJK  
 INSTALLATION CÔTE LATERAL PAS POSSIBLE  
 INSTALLATION OUTER FRAME SIDE NOT POSSIBLE  
 INSTALLATION BLENDRAHMEN SENKRECHT NICHT MÖGLICH

(\*) LED IS INTEGRATED IN SWITCH, FEEDBACK FROM LOCK 062.8682.-- PUSH BUTTON EXTENSION CABLE L:5M  
 (\*\*) ALTERNATIVE: CONNECT BUTTON VIA ELECTRIC CABINET (Cabinet Hub 062.7315.--)

MEER DETAILS BETREFFENDE INSTALLATIE INSTRUCTIES ZIE "PRODUCT INFO" OP ARTIKEL WEBSITE (062.7300.--)  
 PLUS DE DETAILS CONCERNANT LES INSTRUCTIONS D'INSTALLATION VOIRE "PRODUCT INFO" SUR ARTICLE SITE DE WEB (062.7300.--)  
 MORE DETAILS REGARDING INSTALLATION INSTRUCTIONS SEE "PRODUCT INFO" ON ARTICLE WEBSITE (062.7300.--)  
 WEITERE DETAILS ZU INSTALLATIONSANWEISUNGEN FINDEN SIE UNTER "PRODUCT INFO" AUF DER ARTIKEL-WEBSIT (062.7300.--)

**MONORAIL:**

XQ=QX (OG + IG)

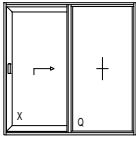

QXQ (OG)

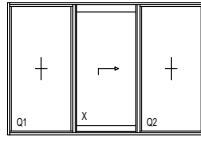

XQX (OG + IG)

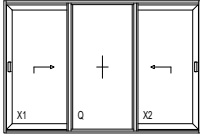

QXXQ (OG + IG)

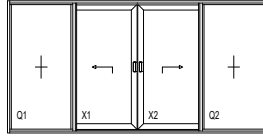

XQVQ=QVQX (OG + IG)

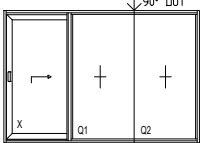

QVQX (OG + IG)

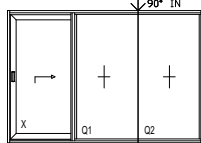

XQVQX (OG + IG)

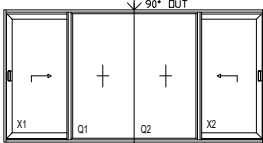

QVQX (OG + IG)

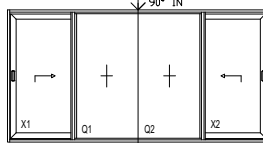

		#
--	--	---

ELEMENT CONTROLLER	062.8610.--		E
SYNC CABLE	062.8580.--		S*E
INPUT BOARD	(* )062.8612.--		1
OUTPUT BOARD	(* )062.8619.--		1
KNX BOARD	(* )062.8620.--		1
ELECTRIC CONTACT GREASE	(* )086.9192.--		1
REYNASTICK	086.9600.XX		1

SLIDE MOTOR	062.7300.--		S
SLIDE MOTOR DOCKING	062.7301.--		S
SLIDE MOTOR CABLE DOCKING (SLIDEHUB)	062.7302.--		S
RETURN PULLEY	062.7303.--		S
CONNECTION SASH	062.7304.--		S
POWER TRANSFER	062.7305.--		L
LIFT MOTOR	062.7306.-- of / ou / or / oder 062.7307.--		L
FLAT CABLE LIFT MOTOR (CHECK HX>3210)	062.8573.--		L or 2*L
HOLE SEAL	062.8377.SY		1
DISTANCE PIECE	062.7309.04		D
BELT	062.8549.-- of / ou / or / oder 062.8256.-- of / ou / or / oder 062.7312.--		1
MOTOR POWER CABLE	062.7317.--		S
MOTOR SIGNAL CABLE	062.7316.--		S
ELECTRIC CABINET	062.7348.--		1
CABINET HUB	062.7315.--		S-1
POWER SUPPLY	062.8647.-- of / ou / or / oder 062.7313.--		S
UNINTERRUPTIBLE POWER SUPPLY	(* )062.8597.--		1
CABINET HUB	062.7315.--		S
LOCAL PUSH BUTTON + CABLES (Connected to slidehub)	(* )062.8219.-- of / ou / or / oder (* )062.8222.-- of / ou / or / oder (* )062.8547.-- of / ou / or / oder (* )062.8682.--		UC
EPDM SEALING PIECE CHICAN	162.9075.04		S
FIXATION: SCREW PLATE	062.7308.--		4*S+3*L
FILL BLOCK USED FOR BUFFER	062.7311.--		L

# Slide motors:  
S = 1 FOR XQ, QXQ, XQVQ  
S = 2 FOR XQX, XQVQX

# Lift motors:  
L = 1 FOR XQ, QXQ, XQVQ  
L = 2 FOR XQX, XQVQX

# Element Controller:  
E=0 FOR XQ, QXQ,  
XQVQ, XQX, XQVQX

# Distance piece:  
D = 0 FOR XQ, QXQ,  
XQVQ, XQX, XQVQX  
D = 1 FOR QXXQ

**!** GEBUIK SPECIAAL BUITENFRAME TOPPROFIEL VOOR MOTORISERING  
 UTILISE LE PROFIL DORMANT EN HAUT DÉDIÉ POUR LA MOTORISATION  
 USE DEDICATED OUTER FRAME TOP PROFILE FOR MOTORISATION  
 VERWENDEN SIE EIN DEDIZIERTES BLENDRAHMEN-OBERPROFIL FÜR DIE MOTORISIERUNG

	STANDARD	MOTORIZED
MONORAIL	406.0323.XX + 406.0320.04	406.0334.XX + 406.0371.XX + 406.0372.04 + 080.9381.04
2RAIL	406.0302.XX + 406.0320.04	

(UC) - HOEVEELHEID AFHANKELIJK VAN DE KEUZE VAN DE KLANT  
 (UC) - QUANTITÉ SELON LE CHOIX DU CLIENT  
 (UC) - QUANTITY DEPENDANT ON CLIENT CHOICE  
 (UC) - ANZAHL JE NACH KUNDENWAHL

(\* ) - KEUZE ARTIKELN / EXTRA VOOR NIET STANDAARD OPLOSSING  
 (\* ) - ARTICLES FACULTATIFS / EXTRA POUR UNE SOLUTION NON STANDARD  
 (\* ) - OPTIONAL ARTICLES / EXTRA FOR NON-STANDARD SOLUTION  
 (\* ) - WAHL ARTIKEL / EXTRA FÜR NICHT-STANDARD-LOSUNG

# MasterPatio Motorised

GEMOTORISEERD ALGEMENE INFORMATIE: BESLISSINGSMATRIX  
MOTORISÉES INFORMATION GENERALITES: MATRICE DE DECISION  
MOTORISED GENERAL INFORMATION: DECISION MATRIX  
MOTORISIERTE ALLGEMEINE INFORMATION: ENTSCHEIDUNGSMATRIX



B

**C**

**R**

Reynaers  
Aluminium





**Profielen**

**Profilés**





**Profiles**

**Profile**



Art. N°			Art. N°		
002.0609.XX	34G.C.007	D3005932	030.3611.XX	34G.C.005	D3005930
002.0609.XX	34G.C.034	D2001507	030.3611.XX	34G.C.028	D2000901
002.0673.XX	34G.C.006	D3005931	030.3612.XX	34G.C.005	D3005930
002.0673.XX	34G.C.033	D3005923	030.3612.XX	34G.C.028	D2000901
002.0674.XX	34G.C.006	D3005931	030.3613.XX	34G.C.005	D3005930
002.0674.XX	34G.C.033	D3005923	030.3613.XX	34G.C.029	D2000903
002.0675.XX	34G.C.006	D3005931	030.3614.XX	34G.C.005	D3005930
002.0675.XX	34G.C.033	D3005923	030.3614.XX	34G.C.029	D2000903
002.0678.XX	34G.C.007	D3005932	030.3615.XX	34G.C.005	D3005930
002.0678.XX	34G.C.034	D2001507	030.3615.XX	34G.C.029	D2000903
002.0679.XX	34G.C.007	D3005932	030.3616.XX	34G.C.005	D3005930
002.0679.XX	34G.C.034	D2001507	030.3616.XX	34G.C.029	D2000903
002.0680.XX	34G.C.007	D3005932	030.3617.XX	34G.C.005	D3005930
002.0680.XX	34G.C.034	D2001507	030.3617.XX	34G.C.029	D2000903
002.0681.XX	34G.C.007	D3005932	030.3618.XX	34G.C.005	D3005930
002.0681.XX	34G.C.034	D3005923	030.3618.XX	34G.C.029	D2000903
002.0682.XX	34G.C.006	D3005931	030.3619.XX	34G.C.005	D3005930
002.0682.XX	34G.C.033	D3005923	030.3619.XX	34G.C.029	D2000903
002.0683.XX	34G.C.007	D3005932	030.3620.XX	34G.C.005	D3005930
002.0683.XX	34G.C.033	D3005923	030.3620.XX	34G.C.030	D0101168
002.0686.XX	34G.C.007	D3005932	030.3622.XX	34G.C.005	D3005930
002.0686.XX	34G.C.033	D3005923	030.3622.XX	34G.C.029	D2000903
002.0687.XX	34G.C.007	D3005932	030.3623.XX	34G.C.005	D3005930
002.0687.XX	34G.C.033	D3005923	030.3623.XX	34G.C.030	D0101168
002.0688.XX	34G.C.007	D3005932	034.0420.XX	34G.C.010	D3006097
002.0688.XX	34G.C.033	D3005923	034.0420.XX	34G.C.054	D3009047
002.0689.XX	34G.C.007	D3005932	043.1028.XX	34G.C.008	D3005929
002.0689.XX	34G.C.034	D2001507	043.1028.XX	34G.C.038	D3005912
002.0690.XX	34G.C.007	D3005932	0M0.1505.XX	34G.C.004	D3006987
002.0690.XX	34G.C.034	D2001507	0M0.1505.XX	34G.C.027	D3009041
002.0691.XX	34G.C.007	D3005932	106.0087.17	34G.C.010	D3006097
002.0691.XX	34G.C.034	D2001507	106.0087.17	34G.C.054	D3009047
002.0692.XX	34G.C.007	D3005932	106.0089.17	34G.C.010	D3006097
002.0692.XX	34G.C.034	D2001507	106.0089.17	34G.C.054	D3009047
002.0693.XX	34G.C.007	D3005932	106.0090.XX	34G.C.010	D3006097
002.0693.XX	34G.C.033	D3005923	106.0090.XX	34G.C.054	D3009047
002.0696.XX	34G.C.007	D3005932	106.0093.XX	34G.C.010	D3006097
002.0696.XX	34G.C.034	D2001507	106.0093.XX	34G.C.054	D3009047
002.0697.XX	34G.C.007	D3005932	130.0920.XX	34G.C.009	D3006096
002.0697.XX	34G.C.034	D2001507	130.0920.XX	34G.C.039	D3005913
002.1676.XX	34G.C.007	D3005932	130.1142.XX	34G.C.010	D3006097
002.1676.XX	34G.C.034	D2001507	130.1142.XX	34G.C.050	D0099429
002.1677.XX	34G.C.007	D3005932	130.1143.XX	34G.C.010	D3006097
002.1677.XX	34G.C.034	D2001507	130.1143.XX	34G.C.049	D0099430
004.3130.XX	34G.C.010	D3006097	130.1147.XX	34G.C.010	D3006097
004.3130.XX	34G.C.049	D0099430	130.1147.XX	34G.C.051	D2001728
004.3167.XX	34G.C.010	D3006097	130.3644.XX	34G.C.005	D3005930
004.3167.XX	34G.C.050	D0099429	130.3644.XX	34G.C.006	D3005931
004.3168.XX	34G.C.010	D3006097	130.3644.XX	34G.C.028	D2000901
004.3168.XX	34G.C.050	D0099429	130.3644.XX	34G.C.031	D0099930
004.3843.XX	34G.C.010	D3006097	130.3645.XX	34G.C.005	D3005930
004.3843.XX	34G.C.049	D0099430	130.3645.XX	34G.C.006	D3005931
011.4633.-	34G.C.008	D3005929	130.3645.XX	34G.C.028	D2000901
011.4633.-	34G.C.035	D3005909	130.3645.XX	34G.C.031	D0099930
030.1099.XX	34G.C.008	D3005929	130.3646.XX	34G.C.006	D3005931
030.1099.XX	34G.C.038	D3005912	130.3646.XX	34G.C.031	D0099930
030.2140.00	34G.C.010	D3006097	130.3647.XX	34G.C.006	D3005931
030.2140.00	34G.C.052	D0099428	130.3647.XX	34G.C.031	D0099930
030.2141.00	34G.C.010	D3006097	130.3648.XX	34G.C.006	D3005931
030.2141.00	34G.C.052	D0099428	130.3648.XX	34G.C.031	D0099930
030.3606.XX	34G.C.005	D3005930	130.3649.XX	34G.C.006	D3005931
030.3606.XX	34G.C.028	D2000901	130.3649.XX	34G.C.031	D0099930
030.3607.XX	34G.C.005	D3005930	130.3650.XX	34G.C.006	D3005931
030.3607.XX	34G.C.028	D2000901	130.3650.XX	34G.C.031	D0099930
030.3608.XX	34G.C.005	D3005930	130.3651.XX	34G.C.006	D3005931
030.3608.XX	34G.C.028	D2000901	130.3651.XX	34G.C.031	D0099930
030.3609.XX	34G.C.005	D3005930	130.3652.XX	34G.C.006	D3005931
030.3609.XX	34G.C.028	D2000901	130.3652.XX	34G.C.031	D0099930
030.3610.XX	34G.C.005	D3005930	130.3653.XX	34G.C.006	D3005931
030.3610.XX	34G.C.028	D2000901	130.3653.XX	34G.C.031	D0099930

Art. N°			Art. N°		
130.3654.XX	34G.C.006	D3005931	406.0332.XX	34G.C.004	D3006987
130.3654.XX	34G.C.031	D0099930	406.0332.XX	34G.C.025	D3005908
130.3655.XX	34G.C.006	D3005931	406.0334.XX	34G.C.002	D3005927
130.3655.XX	34G.C.031	D0099930	406.0334.XX	34G.C.014	D3005898
130.3656.XX	34G.C.006	D3005931	406.0335.XX	34G.C.004	D3006987
130.3656.XX	34G.C.032	D0099934	406.0335.XX	34G.C.024	D3005907
130.3657.XX	34G.C.006	D3005931	406.0336.XX	34G.C.009	D3006096
130.3657.XX	34G.C.032	D0099934	406.0336.XX	34G.C.039	D3005913
130.3658.XX	34G.C.006	D3005931	406.0337.XX	34G.C.003	D3005928
130.3658.XX	34G.C.032	D0099934	406.0337.XX	34G.C.022	D3005903
130.3659.XX	34G.C.006	D3005931	406.0338.XX	34G.C.009	D3006096
130.3659.XX	34G.C.032	D0099934	406.0338.XX	34G.C.039	D3005913
406.0080.00PU	34G.C.008	D3005929	406.0340.XX	34G.C.004	D3006987
406.0080.00PU	34G.C.036	D3005910	406.0340.XX	34G.C.023	D3005906
406.0081.XX	34G.C.008	D3005929	406.0341.04PU	34G.C.004	D3006987
406.0081.XX	34G.C.036	D3005910	406.0341.04PU	34G.C.024	D3005907
406.0090.00PU	34G.C.008	D3005929	406.0342.XX	34G.C.004	D3006987
406.0090.00PU	34G.C.036	D3005910	406.0342.XX	34G.C.024	D3005907
406.0091.XX	34G.C.008	D3005929	406.0343.04	34G.C.004	D3006987
406.0091.XX	34G.C.036	D3005910	406.0343.04	34G.C.023	D3005906
406.0092.00PU	34G.C.008	D3005929	406.0345.XX	34G.C.003	D3005928
406.0092.00PU	34G.C.036	D3005910	406.0346.XX	34G.C.003	D3005928
406.0093.XX	34G.C.008	D3005929	406.0350.XX	34G.C.004	D3006987
406.0093.XX	34G.C.036	D3005910	406.0350.XX	34G.C.026	D3005904
406.0094.00PU	34G.C.008	D3005929	406.0351.04PU	34G.C.004	D3006987
406.0094.00PU	34G.C.037	D3005911	406.0351.04PU	34G.C.024	D3005907
406.0095.XX	34G.C.008	D3005929	406.0360.XX	34G.C.004	D3006987
406.0095.XX	34G.C.037	D3005911	406.0360.XX	34G.C.027	D3009041
406.0096.00PU	34G.C.008	D3005929	406.0363.XX	34G.C.003	D3005928
406.0096.00PU	34G.C.037	D3005911	406.0363.XX	34G.C.022	D3005903
406.0097.XX	34G.C.008	D3005929	406.0364.XX	34G.C.003	D3005928
406.0097.XX	34G.C.037	D3005911	406.0364.XX	34G.C.021	D3005905
406.0099.XXPU	34G.C.008	D3005929	406.0365.XX	34G.C.003	D3005928
406.0099.XXPU	34G.C.038	D3005912	406.0365.XX	34G.C.021	D3005905
406.0300.XXPU	34G.C.002	D3005927	406.0366.XX	34G.C.003	D3005928
406.0300.XXPU	34G.C.015	D3005899	406.0366.XX	34G.C.021	D3005905
406.0302.XX	34G.C.002	D3005927	406.0367.XX	34G.C.003	D3005928
406.0302.XX	34G.C.015	D3005899	406.0367.XX	34G.C.021	D3005905
406.0303.XX	34G.C.002	D3005927	406.0369.XX	34G.C.003	D3005928
406.0305.XXPU	34G.C.002	D3005927	406.0369.XX	34G.C.022	D3005903
406.0310.XX	34G.C.002	D3005927	406.0370.XX	34G.C.002	D3005927
406.0310.XX	34G.C.013	D3005900	406.0370.XX	34G.C.011	D3005897
406.0311.XXPU	34G.C.002	D3005927	406.0371.XX	34G.C.003	D3005928
406.0311.XXPU	34G.C.013	D3005900	406.0371.XX	34G.C.022	D3005903
406.0312.XXPU	34G.C.002	D3005927	406.0372.04	34G.C.003	D3005928
406.0312.XXPU	34G.C.012	D3008177	406.0372.04	34G.C.020	D3005902
406.0315.XX	34G.C.004	D3006987	406.0525.XX	34G.C.002	D3005927
406.0315.XX	34G.C.027	D3009041	406.0527.XX	34G.C.003	D3005928
406.0319.04	34G.C.003	D3005928	406.0580.07	34G.C.010	D3006097
406.0319.04	34G.C.020	D3005902	406.0580.07	34G.C.053	D3007545
406.0320.04	34G.C.003	D3005928	406.0997.XX	34G.C.004	D3006987
406.0320.04	34G.C.020	D3005902	406.0997.XX	34G.C.027	D3009041
406.0321.XXPU	34G.C.002	D3005927	408.0079.XX	34G.C.009	D3006096
406.0321.XXPU	34G.C.011	D3005897	408.0079.XX	34G.C.045	D3003604
406.0322.04	34G.C.003	D3005928	408.0081.XX	34G.C.009	D3006096
406.0322.04	34G.C.020	D3005902	408.0081.XX	34G.C.045	D3003604
406.0323.XX	34G.C.002	D3005927	408.0120.XX	34G.C.004	D3006987
406.0323.XX	34G.C.014	D3005898	408.0120.XX	34G.C.026	D3005904
406.0324.04	34G.C.003	D3005928	408.0164.XX	34G.C.009	D3006096
406.0324.04	34G.C.020	D3005902	408.0164.XX	34G.C.041	D3005926
406.0325.XX	34G.C.002	D3005927	408.0176.XX	34G.C.009	D3006096
406.0325.XX	34G.C.017	D3005901	408.0176.XX	34G.C.044	D3006035
406.0326.04	34G.C.003	D3005928	408.0180.XX	34G.C.009	D3006096
406.0326.04	34G.C.020	D3005902	408.0180.XX	34G.C.044	D3006035
406.0327.XX	34G.C.002	D3005927	408.0442.XX	34G.C.009	D3006096
406.0327.XX	34G.C.017	D3005901	408.0442.XX	34G.C.046	D0098846
406.0330.XX	34G.C.004	D3006987	408.0442.XX	34G.C.047	D0101159
406.0330.XX	34G.C.025	D3005908	408.0442.XX	34G.C.048	D0098847
406.0331.04PU	34G.C.004	D3006987	408.0443.XX	34G.C.009	D3006096
406.0331.04PU	34G.C.025	D3005908	408.0443.XX	34G.C.047	D0101159

Art. N°			Art. N°		
408.0444.XX	34G.C.009	D3006096			
408.0444.XX	34G.C.048	D0098847			
408.0549.XX	34G.C.009	D3006096			
408.0549.XX	34G.C.039	D3005913			
408.0884.XX	34G.C.009	D3006096			
408.0884.XX	34G.C.042	D3006033			
408.3180.XX	34G.C.009	D3006096			
408.3180.XX	34G.C.043	D3006650			
408.4001.XX	34G.C.009	D3006096			
408.4001.XX	34G.C.040	D3006032			
508.0164.XX	34G.C.041	D3005926			
508.0442.XX	34G.C.046	D0098846			
508.0443.XX	34G.C.047	D0101159			
508.0444.XX	34G.C.048	D0098847			
508.3180.XX	34G.C.043	D3006650			

C



**BUITENKADER ONDER  
DORMANT EN BAS  
OUTER FRAME BOTTOM  
BLENDRAHMEN UNTEN**

			$\frac{A}{dm^2/m}$	$\frac{P}{dm^2/m}$	$\leftarrow L_m \rightarrow$	$I_x \text{ cm}^4$	$I_y \text{ cm}^4$
406.0321.XXPU			71.76	12.9	7.00 5.50 4.00	82.700	30.721

406.0370.XX			11.96	3.0	7.00	0.189	0.776
-------------	--	--	-------	-----	------	-------	-------

406.0312.XXPU			76.93	13.3	7.00 5.50 4.00	200.027	34.429
---------------	--	--	-------	------	----------------------	---------	--------

406.0311.XXPU			54.67	10.9	7.00 5.50	82.030	28.645
---------------	--	--	-------	------	--------------	--------	--------

406.0310.XX			6.29	1.4	7.00 5.50	0.026	0.111
-------------	--	--	------	-----	--------------	-------	-------

**BUITENKADER BOVEN  
DORMANT EN HAUT  
OUTER FRAME TOP  
BLENDRAHMEN OBEN**

			$\frac{A}{dm^2/m}$	$\frac{P}{dm^2/m}$	$\leftarrow L_m \rightarrow$	$I_x \text{ cm}^4$	$I_y \text{ cm}^4$
406.0323.XX			72.38	18.6	7.00 5.50 4.00	83.310	31.973

406.0334.XX			69.32	32.6	7.00	168.155	34.170
-------------	--	--	-------	------	------	---------	--------

**BUITENKADER ONDER  
DORMANT EN BAS  
OUTER FRAME BOTTOM  
BLENDRAHMEN UNTEN**

			$\frac{A}{dm^2/m}$	$\frac{P}{dm^2/m}$	$\leftarrow L_m \rightarrow$	$I_x \text{ cm}^4$	$I_y \text{ cm}^4$
406.0300.XXPU			54.67	19.1	7.00 5.50 4.00	60.750	45.221

**BUITENKADER BOVEN  
DORMANT EN HAUT  
OUTER FRAME TOP  
BLENDRAHMEN OBEN**

			$\frac{A}{dm^2/m}$	$\frac{P}{dm^2/m}$	$\leftarrow L_m \rightarrow$	$I_x \text{ cm}^4$	$I_y \text{ cm}^4$
406.0302.XX			53.75	22.1	7.00 5.50 4.00	47.830	42.930

**BUITENKADER ONDER  
DORMANT BAS  
OUTER FRAME BOTTOM  
BLENDRAHMEN UNTEN**

			$\frac{A}{dm^2/m}$	$\frac{P}{dm^2/m}$	$\leftarrow L_m \rightarrow$	$I_x \text{ cm}^4$	$I_y \text{ cm}^4$
406.0305.XXPU			86.99	19.1	7.00	819.342	59.375

**BUITENKADER BOVEN  
DORMANT EN HAUT  
OUTER FRAME TOP  
BLENDRAHMEN OBEN**

			$\frac{A}{dm^2/m}$	$\frac{P}{dm^2/m}$	$\leftarrow L_m \rightarrow$	$I_x \text{ cm}^4$	$I_y \text{ cm}^4$
406.0303.XX			87.74	22.1	7.00 4.00	1537.973	58.441

**BUITENKADER ZIJKANT  
DORMANT COTE LATERAL  
OUTER FRAME SIDE  
BLENDRAHMEN SENKRECHT**

			$\frac{A}{dm^2/m}$	$\frac{P}{dm^2/m}$	$\leftarrow L_m \rightarrow$	$I_x \text{ cm}^4$	$I_y \text{ cm}^4$
406.0325.XX			57.04	21.3	7.00 4.00 3.00	190.522	17.279

406.0327.XX			51.94	20.1	7.00 4.00 3.00	201.996	15.509
-------------	--	--	-------	------	----------------------	---------	--------

406.0525.XX			84.06	25.3	7.00 4.00 3.00	189.799	50.089
-------------	--	--	-------	------	----------------------	---------	--------

**BUITENKADER ZIJKANT**  
**DORMANT COTE LATERAL**  
**OUTER FRAME SIDE**  
**BLENDRAHMEN SENKRECHT**

			$\frac{A}{dm^2/m}$	$\frac{P}{dm^2/m}$	$L_m$	$I_x \text{ cm}^4$	$I_y \text{ cm}^4$
406.0527.XX			55.93	24.1	7.00 4.00 3.00	253.406	47.085
406.0345.XX			28.45	28.4	7.00 5.00	172.707	17.753
406.0346.XX			36.19	13.1	7.00 5.00	53.909	7.633

**PROFIEL BUITENKADER KUNSTSTOF**  
**PROFILE SYNTHETIQUE DORMANT**  
**SYNTHETIC PROFILE OUTER FRAME**  
**KUNSTSTOFFPROFIL BLENDRAHMEN**

			$\frac{A}{dm^2/m}$	$\frac{P}{dm^2/m}$	$L_m$	$I_x \text{ cm}^4$	$I_y \text{ cm}^4$
406.0320.04			0.08	0.1	7.00 5.50 4.00	3.559	2.561
406.0324.04			0.01	-	7.00	0.241	0.111
406.0326.04			0.02	-	7.00	1.069	0.820
406.0322.04			-	-	7.00	1.225	0.177
406.0319.04			0.04	-	7.00	3.597	0.306
406.0372.04			0.01	-	7.00	0.405	0.017

**AFDEKPROFIEL**  
**PROFILE DE RECOUVREMENT**  
**COVERING PROFILE**  
**ABDECKPROFIL**

			$\frac{A}{dm^2/m}$	$\frac{P}{dm^2/m}$	$L_m$	$I_x \text{ cm}^4$	$I_y \text{ cm}^4$
406.0365.XX			33.78	13.9	7.00 3.00	44.090	0.568
406.0364.XX			30.52	13.2	7.00 3.00	37.279	0.548
406.0367.XX			33.20	11.6	7.00	30.711	1.114
406.0366.XX			36.03	13.1	7.00 3.00	29.741	3.227
406.0363.XX			33.43	11.5	7.00 3.00	29.724	1.184
406.0337.XX			36.74	13.8	7.00 3.00	30.412	3.274
406.0369.XX			32.27	11.1	7.00	1.266	32.781
406.0371.XX			10.90	5.0	3.00	1.732	0.010

## VLEUGELPROFIEL PROFILE OUVRANT VENT PROFILE FLUEGELPROFIL

			$\frac{A}{dm^2/m}$	$\frac{P}{dm^2/m}$	$\leftarrow L_m \rightarrow$	$I_x \text{ cm}^4$	$I_y \text{ cm}^4$
406.0340.XX			38.92	31.7	7.00 5.50	28.050	20.342
406.0343.04			-	-	7.00	2.024	0.299

## WISSELPROFIEL CHICANE MEETING SECTION WECHSELPROFIL

			$\frac{A}{dm^2/m}$	$\frac{P}{dm^2/m}$	$\leftarrow L_m \rightarrow$	$I_x \text{ cm}^4$	$I_y \text{ cm}^4$
406.0335.XX			32.62	11.2	7.00 5.50	21.979	10.955
406.0342.XX			28.19	12.0	7.00 5.50	28.356	1.126
406.0341.04			0.08	0.1	7.00	2.347	6.979
406.0351.04PU			0.01	-	7.00	1.550	4.564
406.0330.XX			23.90	10.0	7.00 5.50	20.340	2.050
406.0332.XX			26.64	11.3	7.00 5.50	26.208	0.528
406.0331.04PU			0.08	0.1	7.00	2.668	2.212

## T-PROFIEL TRAVERSE TRANSOM RIEGEL

			$\frac{A}{dm^2/m}$	$\frac{P}{dm^2/m}$	$\leftarrow L_m \rightarrow$	$I_x \text{ cm}^4$	$I_y \text{ cm}^4$
406.0350.XX			27.90	17.9	7.00 5.50	22.815	3.171
408.0120.XX			35.38	12.9	7.00 5.00	26.409	14.154
406.0360.XX			50.65	28.8	7.00 5.50	213.008	29.559

## MIDDENSTIJL 4-SLAG LIAISON CENTRALE 4 VANTAUX MEETING STYLE 4 DOORS STULPPROFIL TUERFLUEGEL 4-SCHLAG

			$\frac{A}{dm^2/m}$	$\frac{P}{dm^2/m}$	$\leftarrow L_m \rightarrow$	$I_x \text{ cm}^4$	$I_y \text{ cm}^4$
406.0997.XX			26.73	8.0	4.00	16.618	8.875

## RECHTHOEKIGE STAAF BARRE RECTANGULAIRE RECTANGULAR BAR FLACHPROFIL

			$\frac{A}{dm^2/m}$	$\frac{P}{dm^2/m}$	$\leftarrow L_m \rightarrow$	$I_x \text{ cm}^4$	$I_y \text{ cm}^4$
0M0.1505.XX			4.00	4.0	6.00	0.140	0.015

## HULPPROFIEL PROFILE DE RACCORDEMENT ADDITIONAL PROFILE ZUSATZPROFIL

			$\frac{A}{dm^2/m}$	$\frac{P}{dm^2/m}$	$\leftarrow L_m \rightarrow$	$I_x \text{ cm}^4$	$I_y \text{ cm}^4$
406.0315.XX			39.71	25.4	7.00 4.00	78.897	24.469

## GLASLAT PARCLOSE GLAZING BEAD GLASLEISTE

			$\frac{A}{dm^2/m}$	$\frac{P}{dm^2/m}$	$L_m$	$I_x \text{ cm}^4$	$I_y \text{ cm}^4$
<b>130.3644.XX</b>			10.17	2.8	-	-	
<b>130.3645.XX</b>			10.75	3.1	-	-	
<b>030.3606.XX</b>			12.37	3.4	7.00	0.277	0.919
<b>030.3607.XX</b>			15.10	3.7	7.00	0.333	0.894
<b>030.3608.XX</b>			15.09	4.0	7.00	0.431	0.914
<b>030.3609.XX</b>			15.54	4.3	7.00	0.548	0.970
<b>030.3610.XX</b>			16.16	4.6	7.00	0.690	1.019
<b>030.3611.XX</b>			16.91	4.9	7.00	0.874	1.072
<b>030.3612.XX</b>			18.96	5.2	7.00	0.995	1.148
<b>030.3613.XX</b>			19.56	5.5	7.00	1.191	1.183
<b>030.3614.XX</b>			20.15	5.8	7.00	1.437	1.218
<b>030.3615.XX</b>			20.83	6.1	7.00	1.756	1.254
<b>030.3616.XX</b>			21.68	6.4	7.00	2.196	1.329
<b>030.3617.XX</b>			22.47	6.7	7.00	2.617	1.365
<b>030.3618.XX</b>			23.28	7.0	7.00	3.098	1.400
<b>030.3619.XX</b>			23.62	7.3	7.00	3.542	1.424
<b>030.3622.XX</b>			24.25	7.6	7.00	4.085	1.446
<b>030.3623.XX</b>			24.82	7.9	7.00	4.685	1.473
<b>030.3620.XX</b>			25.50	8.2	7.00	5.328	1.481

## GLASLAT PARCLOSE GLAZING BEAD GLASLEISTE

			$\frac{A}{dm^2/m}$	$\frac{P}{dm^2/m}$	$L_m$	$I_x \text{ cm}^4$	$I_y \text{ cm}^4$
130.3644.XX			10.17	2.8		-	-
130.3645.XX			10.75	3.1		-	-
130.3646.XX			12.99	3.4		-	-
130.3647.XX			9.53	3.7		-	-
130.3648.XX			9.60	4.0	7.00	1.113	0.458
130.3649.XX			9.62	4.3	7.00	1.165	0.545
130.3650.XX			10.09	4.6	7.00	1.257	0.739
130.3651.XX			10.61	4.9	7.00	1.314	0.898
130.3652.XX			11.16	5.2	7.00	1.376	1.127
130.3653.XX			11.71	5.5	7.00	1.434	1.408
130.3654.XX			12.26	5.8	7.00	1.488	1.742
130.3655.XX			12.82	6.1	7.00	1.540	2.133
130.3656.XX			14.09	6.4	7.00	1.649	2.059
130.3657.XX			14.69	6.7	7.00	1.691	2.417
130.3658.XX			15.29	7.0	7.00	1.730	2.833
130.3659.XX			15.89	7.3	7.00	1.768	3.307
002.0673.XX			10.68	2.5	7.00	0.239	0.227
002.0674.XX			10.90	2.8	7.00	0.286	0.239
002.0675.XX			11.25	3.1	7.00	0.349	0.254
002.0682.XX			11.82	3.4	7.00	0.431	0.266

**GLASLAT  
 PARCLOSE  
 GLAZING BEAD  
 GLASLEISTE**

			$\frac{A}{dm^2/m}$	$\frac{P}{dm^2/m}$	$L_m$	$I_x \text{ cm}^4$	$I_y \text{ cm}^4$
002.0693.XX			13.49	3.7	7.00	0.547	0.291
002.0683.XX			14.08	4.1	7.00	0.669	0.300
002.0687.XX			14.68	4.4	7.00	0.822	0.311
002.0686.XX			15.28	4.7	7.00	1.011	0.321
002.0688.XX			15.88	5.0	7.00	1.237	0.331
002.0609.XX			7.95	1.8	6.00	0.189	0.227
002.1676.XX			9.59	2.2	7.00	0.210	0.235
002.1677.XX			10.19	2.5	7.00	0.222	0.264
002.0678.XX			7.69	2.8	7.00	0.259	0.298
002.0679.XX			7.93	3.1	7.00	0.322	0.323
002.0680.XX			8.36	3.4	7.00	0.421	0.351
002.0681.XX			10.43	3.7	7.00	0.532	0.376
002.0692.XX			10.80	4.0	7.00	0.629	0.388
002.0689.XX			11.31	4.3	7.00	0.772	0.409
002.0691.XX			12.02	4.6	7.00	0.993	0.425
002.0690.XX			12.22	4.9	7.00	1.126	0.439
002.0696.XX			12.84	5.2	7.00	1.618	0.473
002.0697.XX			13.44	5.5	7.00	1.940	0.486

**RAIL**  
**RAIL**  
**RAIL**  
**RAIL**

			$\frac{A}{dm^2/m}$	$\frac{P}{dm^2/m}$	$L_m$	$I_x \text{ cm}^4$	$I_y \text{ cm}^4$
011.4633.--			0.03	-	7.00	0.007	0.019

			$\frac{A}{dm^2/m}$	$\frac{P}{dm^2/m}$	$L_m$	$I_x \text{ cm}^4$	$I_y \text{ cm}^4$
406.0096.00PU			21.45	-	7.00	7.093	56.439

**VERSTEVIGINGSPROFIEL**  
**PROFILE DE RENFORCEMENT**  
**REINFORCEMENT PROFILE**  
**VERSTAERKUNGSPROFIL**

			$\frac{A}{dm^2/m}$	$\frac{P}{dm^2/m}$	$L_m$	$I_x \text{ cm}^4$	$I_y \text{ cm}^4$
406.0080.00PU			0.01	-	7.00	0.095	5.227

406.0097.XX			29.92	14.5	7.00	1.919	27.252
-------------	--	--	-------	------	------	-------	--------

406.0081.XX			13.79	7.0	7.00	0.062	3.244
-------------	--	--	-------	-----	------	-------	-------

406.0099.XX			19.92	11.5	4.00	12.418	3.826
-------------	--	--	-------	------	------	--------	-------

406.0090.00PU			14.37	-	7.00	4.081	10.352
---------------	--	--	-------	---	------	-------	--------

030.1099.XX			22.25	13.6	7.00	21.049	5.071
-------------	--	--	-------	------	------	--------	-------

406.0091.XX			22.33	11.0	7.00	1.629	7.878
-------------	--	--	-------	------	------	-------	-------

043.1028.XX			9.59	2.3	6.00	-	-
-------------	--	--	------	-----	------	---	---

406.0092.00PU			18.57	-	7.00	17.098	15.784
---------------	--	--	-------	---	------	--------	--------

406.0093.XX			30.18	15.0	7.00	7.039	11.816
-------------	--	--	-------	------	------	-------	--------

406.0094.00PU			22.37	-	7.00	40.667	20.356
---------------	--	--	-------	---	------	--------	--------

406.0095.XX			38.18	19.0	7.00	17.420	15.346
-------------	--	--	-------	------	------	--------	--------

## AFWERKINGSPROFIEL PROFILE DE FINITION FINISHING PROFILE AUSFUEHRUNGSPROFIL

			$\frac{A}{dm^2/m}$	$\frac{P}{dm^2/m}$	$L_m$	$I_x \text{ cm}^4$	$I_y \text{ cm}^4$
406.0336.XX			9.72	4.7	7.00	0.120	1.079
406.0338.XX			14.73	6.5	7.00	1.113	1.817
408.0549.XX			12.18	3.1	7.00	0.288	0.950
130.0920.XX			18.56	6.2	7.00	0.411	2.075

## OMKEERPROFIEL PROFILE INVERSION CHANGEOVER PROFILE WECHSELPROFIL

			$\frac{A}{dm^2/m}$	$\frac{P}{dm^2/m}$	$L_m$	$I_x \text{ cm}^4$	$I_y \text{ cm}^4$
408.4001.XX			32.00	8.0	7.00	21.863	8.387

## KOPPELPROFIEL 180 MM PROFILE DE RACCORDEMENT 180 MM CONNECTION PROFILE 180 MM KUPPLUNGSPROFIL 180 MM

			$\frac{A}{dm^2/m}$	$\frac{P}{dm^2/m}$	$L_m$	$I_x \text{ cm}^4$	$I_y \text{ cm}^4$
408.0164.XX			51.09	19.2	7.00	172.339	17.169
408.0884.XX			65.49	20.1	7.00	196.841	15.442
408.3180.XX			55.84	32.6	7.00	209.119	25.565

			$\frac{A}{dm^2/m}$	$\frac{P}{dm^2/m}$	$L_m$	$I_x \text{ cm}^4$	$I_y \text{ cm}^4$
408.0176.XX			41.29	26.6	7.00	147.373	7.332
408.0180.XX			47.96	16.2	7.00	165.624	4.649

## DILATATIEPROFIEL 27MM PROFILE DE DILATATION 27MM EXPANSION PROFILE 27MM AUSDEHNUNGSPROFIL 27MM

			$\frac{A}{dm^2/m}$	$\frac{P}{dm^2/m}$	$L_m$	$I_x \text{ cm}^4$	$I_y \text{ cm}^4$
408.0079.XX			12.88	-	7.00	0.251	0.930
408.0081.XX			16.01	3.1	7.00	0.667	0.886

## Z-PROFIEL 80MM PROFILE-Z 80MM Z-PROFILE 80MM Z-PROFIL 80MM

			$\frac{A}{dm^2/m}$	$\frac{P}{dm^2/m}$	$L_m$	$I_x \text{ cm}^4$	$I_y \text{ cm}^4$
408.0442.XX			33.98	11.5	7.00	24.899	10.131
408.0443.XX			35.38	12.9	7.00	27.682	14.154
408.0444.XX			39.38	17.3	7.00	34.939	32.465

## AFWERKINGSPROFIEL PROFILE DE FINITION FINISHING PROFILE AUSFUEHRUNGSPROFIL

			$\frac{A}{dm^2/m}$	$\frac{P}{dm^2/m}$	$\leftarrow L_m \rightarrow$	$I_x \text{ cm}^4$	$I_y \text{ cm}^4$
004.3130.XX			19.05	1.6	6.00	1.141	1.881
004.3843.XX			24.19	8.1	6.00	3.916	1.609
130.1143.XX			22.82	7.9	6.00	3.500	2.249
004.3167.XX			35.96	12.9	6.00	9.873	3.238
004.3168.XX			54.76	30.3	6.00	41.102	5.965
130.1142.XX			34.76	6.6	6.00	-	-
130.1147.XX			30.22	11.5	6.00	4.375	15.694
030.2140.00			-	-	7.00	6.246	2.235
030.2141.00			-	-	7.00	5.613	1.162

## STEUNPROFIEL PROFILE DE SUPPORT RAFTER HOLDER SPARREAUFLAGEPROFIL

			$\frac{A}{dm^2/m}$	$\frac{P}{dm^2/m}$	$\leftarrow L_m \rightarrow$	$I_x \text{ cm}^4$	$I_y \text{ cm}^4$
406.0580.07			0.01	-	4.00	917.120	31.490

## GOOT GOUTTIERE GUTTER RINNENPROFIL

			$\frac{A}{dm^2/m}$	$\frac{P}{dm^2/m}$	$\leftarrow L_m \rightarrow$	$I_x \text{ cm}^4$	$I_y \text{ cm}^4$
106.0087.17			55.42	0.1	7.00	44.100	8.767
106.0093.XX			24.58	0.1	7.00	7.366	3.486
106.0089.17			63.02	-	7.00	53.391	37.895
106.0090.XX			25.66	5.3	7.00	7.337	3.645
034.0420.XX			13.85	6.5	7.00	0.152	1.094

	$\frac{A}{dm^2/m}$	$\frac{P}{dm^2/m}$	$L_m$	$I_x \text{ cm}^4$	$W_x \text{ cm}^3$	ax mm	$I_y \text{ cm}^4$	$W_y \text{ cm}^3$	ay mm	
406.0321.XXPU	71.76	12.9	7.00/5.50/4.00	82.700	8.110	102.02	30.721	8.079	22.18	
406.0370.XX	11.96	7.0	7.00	0.189	0.171	11.07	0.776	0.417	18.60	

406.0321.XXPU

406.0370.XX

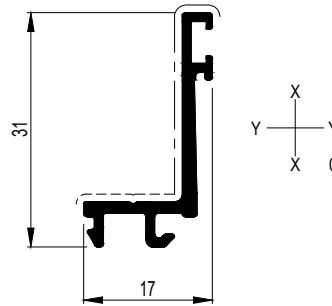
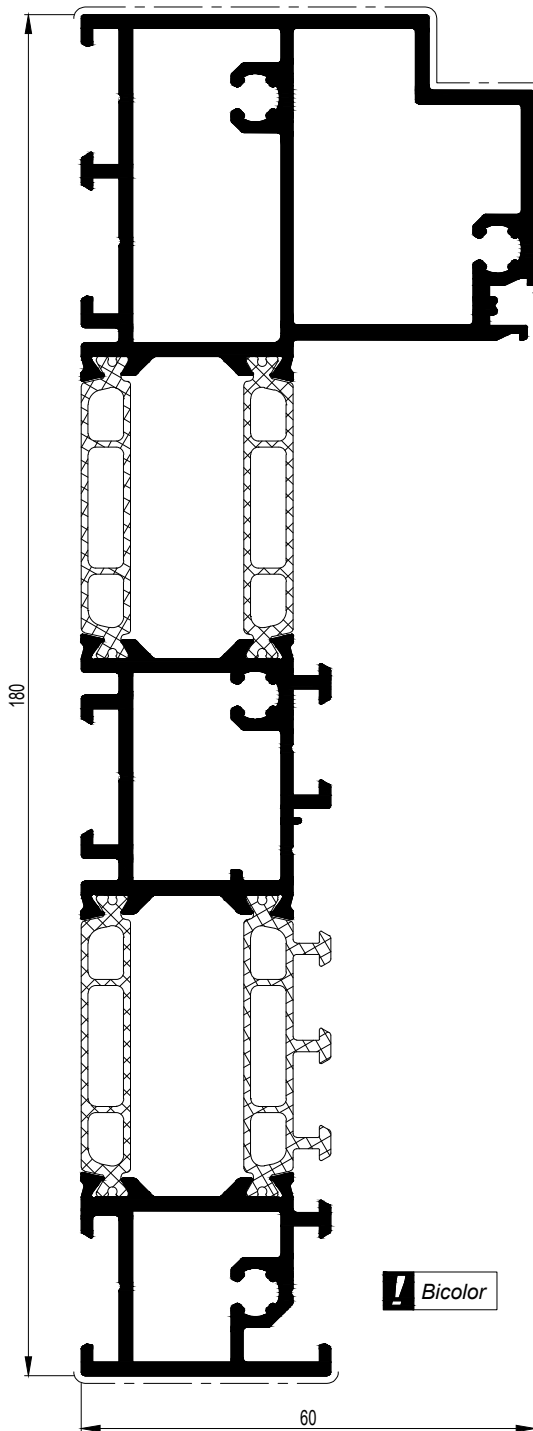



	<b>406.0321.XXPU</b>	
	052.5371.--	--

	$\frac{A}{dm^2/m}$	$\frac{P}{dm^2/m}$	$L_m$	$I_x \text{ cm}^4$	$W_x \text{ cm}^3$	ax mm	$I_y \text{ cm}^4$	$W_y \text{ cm}^3$	ay mm	Y X 0 Y
406.0312.XXPU	76.93	13.3	7.00/5.50/4.00	200.027	19.859	100.72	34.429	9.393	23.39	

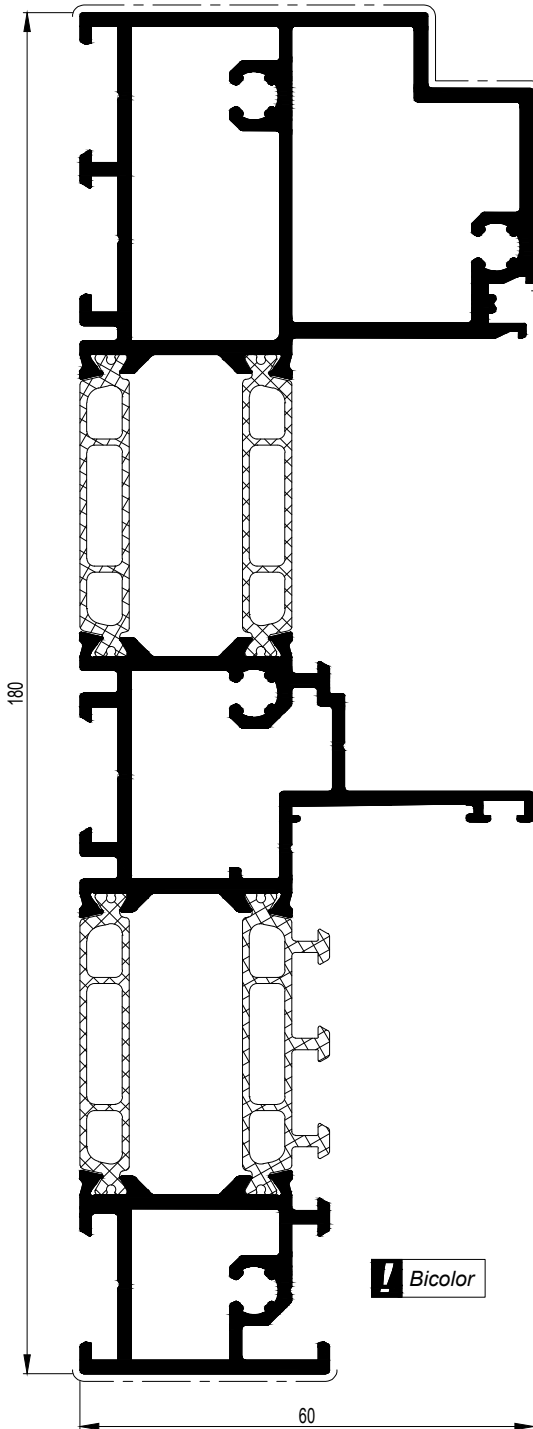
406.0312.XXPU



 406.0312.XXPU	
 052.5371.--	--

	$\frac{A}{dm^2/m}$	$\frac{P}{dm^2/m}$	$L_m$	$I_x \text{ cm}^4$	$W_x \text{ cm}^3$	$a_x \text{ mm}$	$I_y \text{ cm}^4$	$W_y \text{ cm}^3$	$a_y \text{ mm}$	
406.0311.XXPU	54.67	10.9	7.00/5.50	82.030	11.300	72.62	28.645	7.778	36.83	
406.0310.XX	6.29	1.4	7.00/5.50	0.026	0.057	4.50	0.111	0.113	9.77	

406.0311.XXPU

406.0310.XX

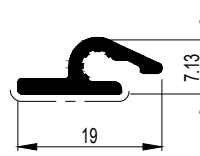
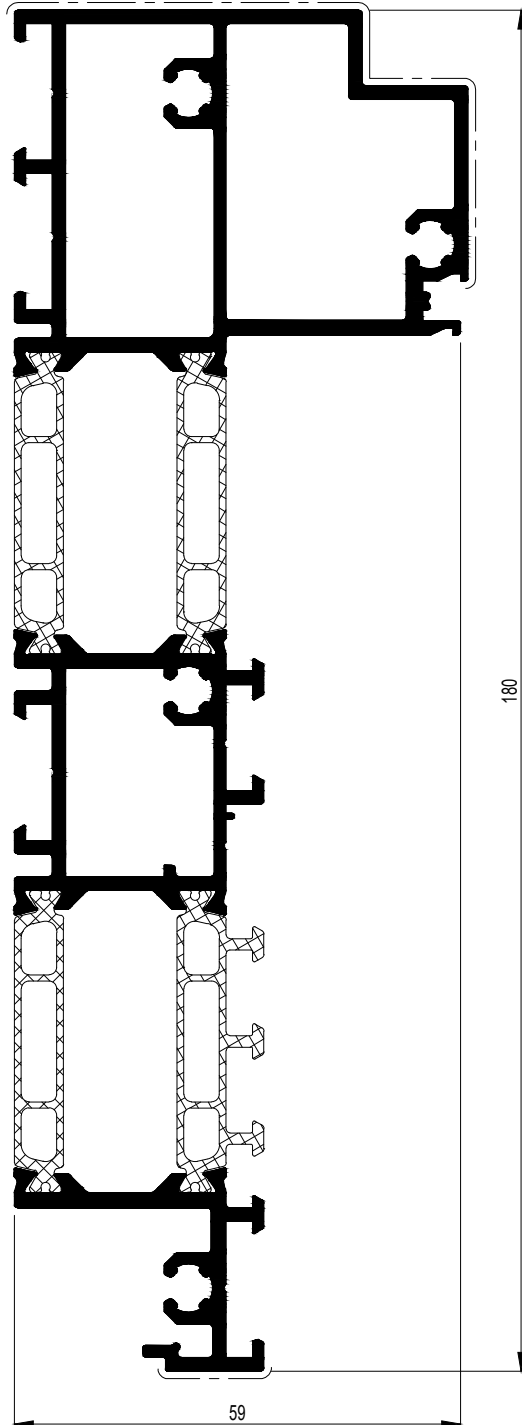

	<b>406.0311.XXPU</b>	
	052.5371.--	---

	$\frac{A}{dm^2/m}$	$\frac{P}{dm^2/m}$	$L_m$	$I_x \text{ cm}^4$	$W_x \text{ cm}^3$	ax mm	$I_y \text{ cm}^4$	$W_y \text{ cm}^3$	ay mm	
406.0323.XX	72.38	18.6	7.00/5.50/4.00	83.310	8.380	99.30	31.973	8.878	36.02	
406.0334.XX	69.32	32.6	7.00	168.155	16.960	80.85	34.170	9.589	35.64	

406.0323.XX

406.0334.XX

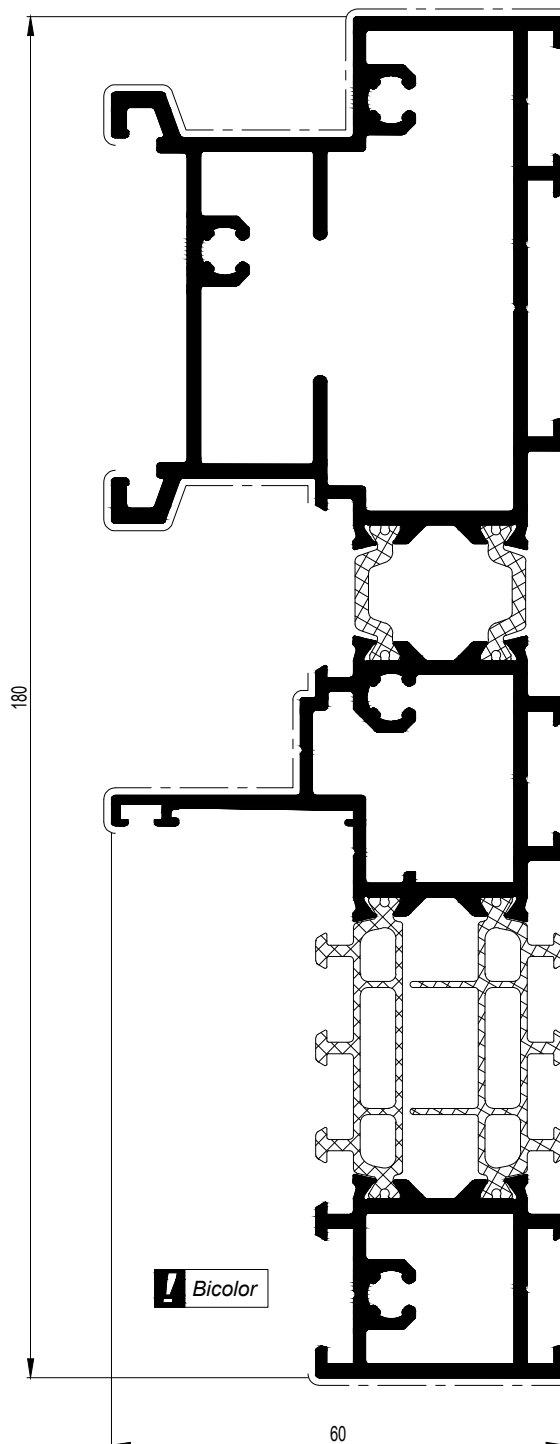
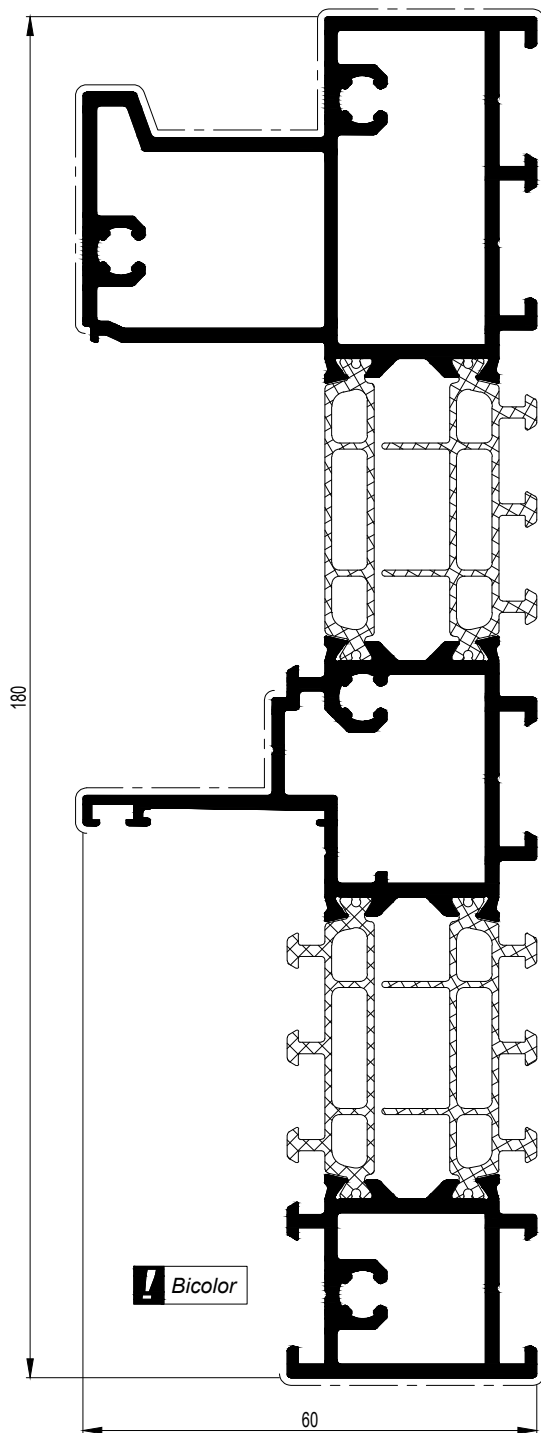

	<b>406.0323.XX</b>	
	052.5371.--	

	$\frac{A}{dm^2/m}$	$\frac{P}{dm^2/m}$	$\leftarrow L_m \rightarrow$	$I_x \text{ cm}^4$	$W_x \text{ cm}^3$	ax mm	$I_y \text{ cm}^4$	$W_y \text{ cm}^3$	ay mm	
406.0300.XXPU	54.67	19.1	7.00/5.50/4.00	60.750	6.740	90.10	45.221	13.484	33.54	
406.0302.XX	53.75	22.1	7.00/5.50/4.00	47.830	5.310	90.10	42.930	12.908	33.26	

406.0300.XXPU

406.0302.XX

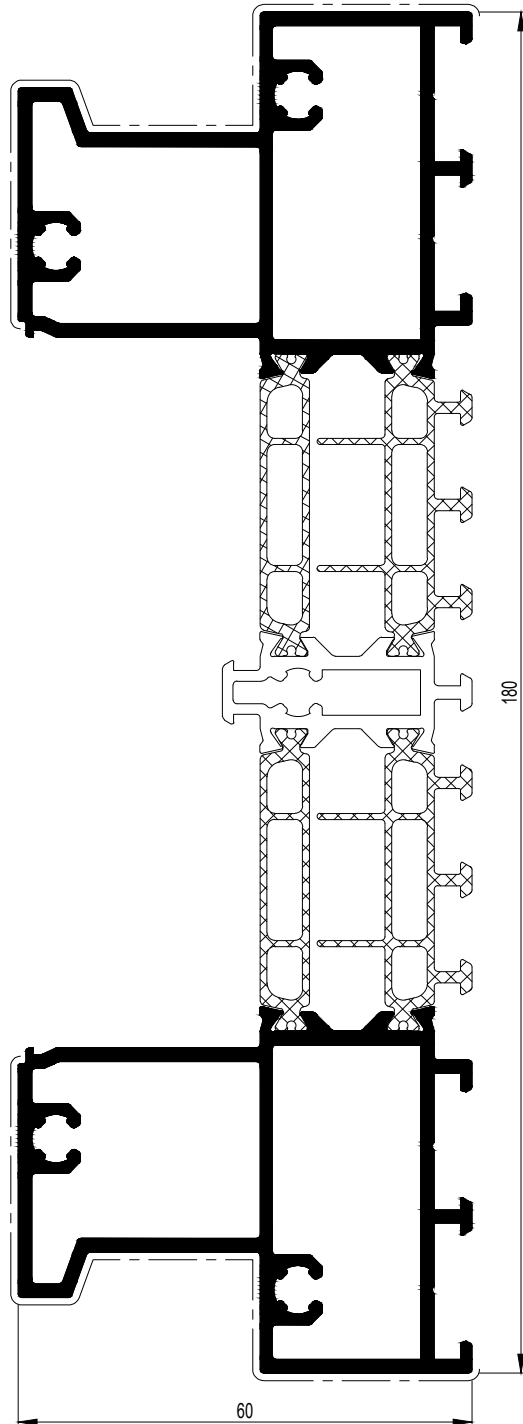
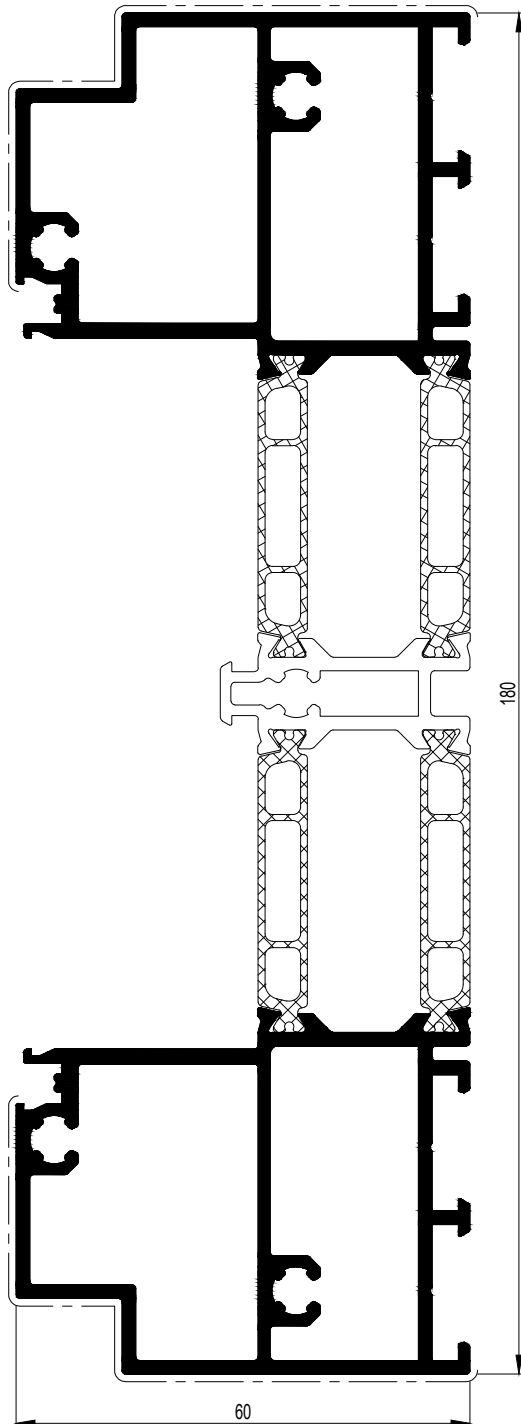

<b>406.0300.XXPU</b>	<b>406.0302.XX</b>
052.5371.--     ---	052.5371.--     ---

	$\frac{A}{dm^2/m}$	$\frac{P}{dm^2/m}$	$L_m$	$I_x \text{ cm}^4$	$W_x \text{ cm}^3$	ax mm	$I_y \text{ cm}^4$	$W_y \text{ cm}^3$	ay mm	
406.0305.XXPU	86.99	19.1	7.00	819.342	57.904	141.50	59.375	17.170	34.58	X Y 0
406.0303.XX	87.74	22.1	7.00/4.00	1537.973	108.691	141.50	58.441	16.938	25.50	

406.0305.XXPU

406.0303.XX

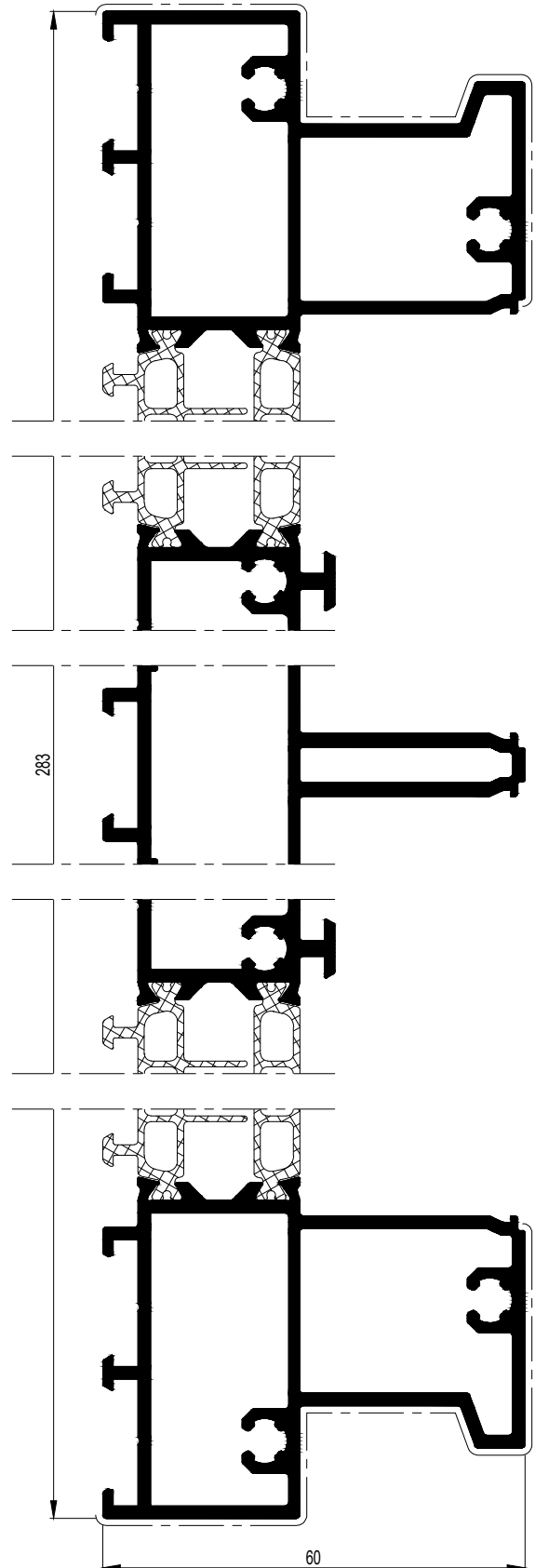
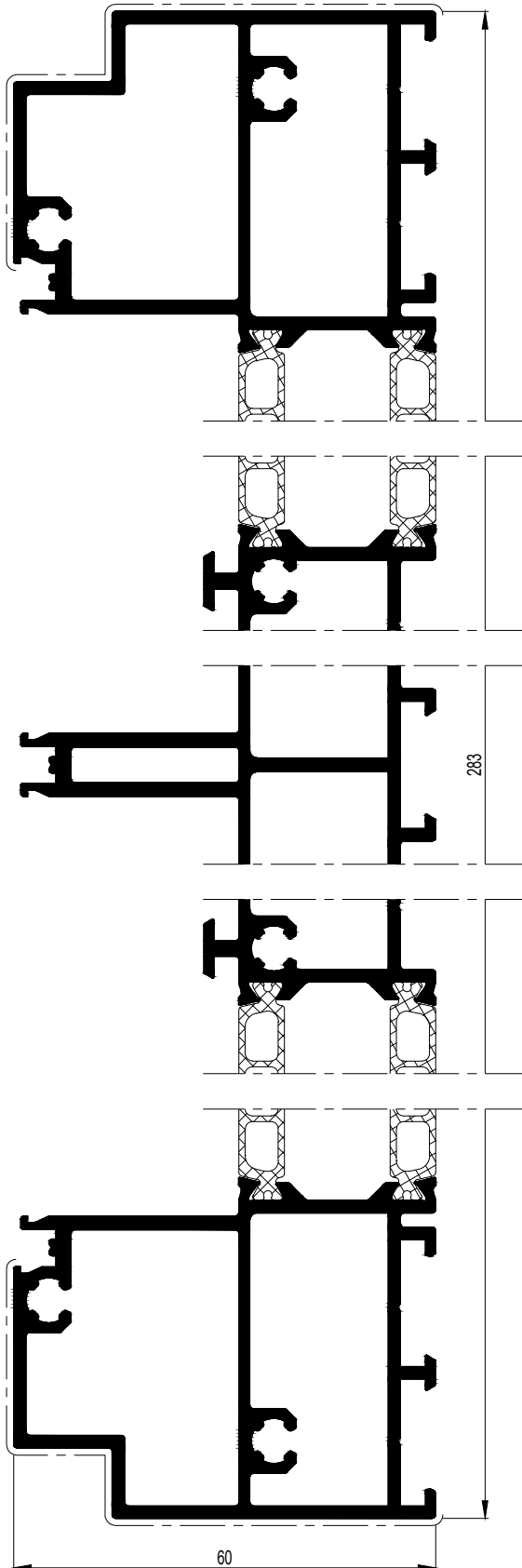



	$\frac{A}{dm^2/m}$	$\frac{P}{dm^2/m}$	$L_m$	$I_x \text{ cm}^4$	$W_x \text{ cm}^3$	ax mm	$I_y \text{ cm}^4$	$W_y \text{ cm}^3$	ay mm	
406.0327.XX	51.94	20.1	7.00/4.00/3.00	201.996	22.094	91.42	15.509	3.832	19.52	
406.0325.XX	57.04	21.3	7.00/4.00/3.00	190.522	19.354	98.44	17.279	6.490	20.59	

406.0325.XX

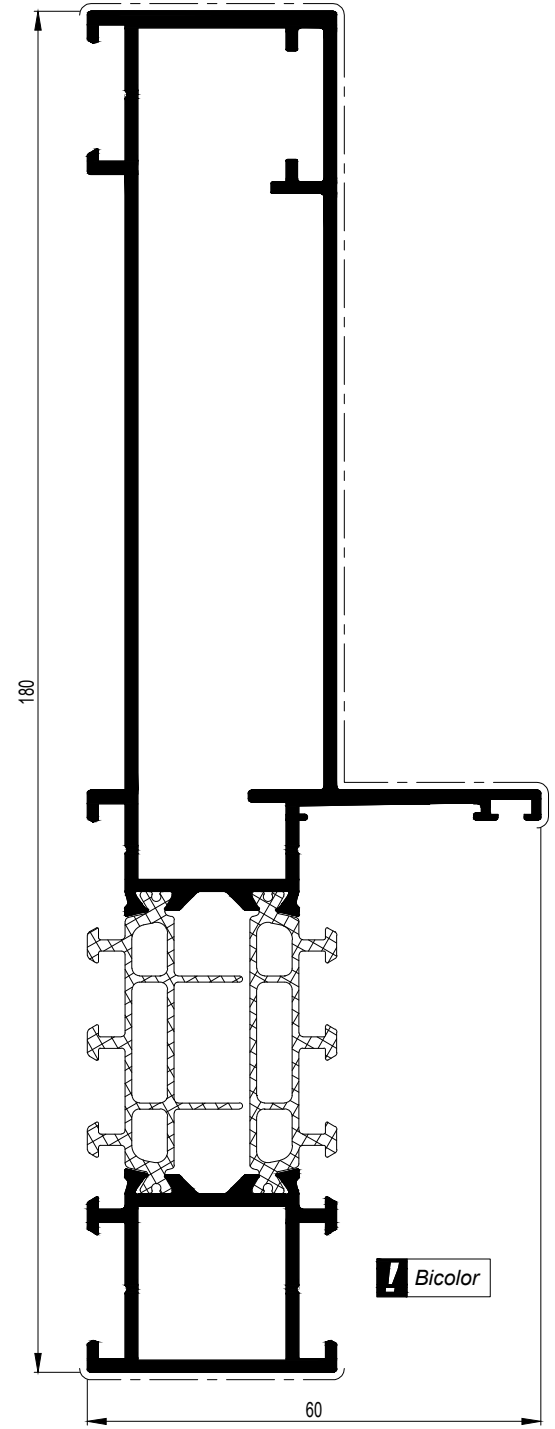
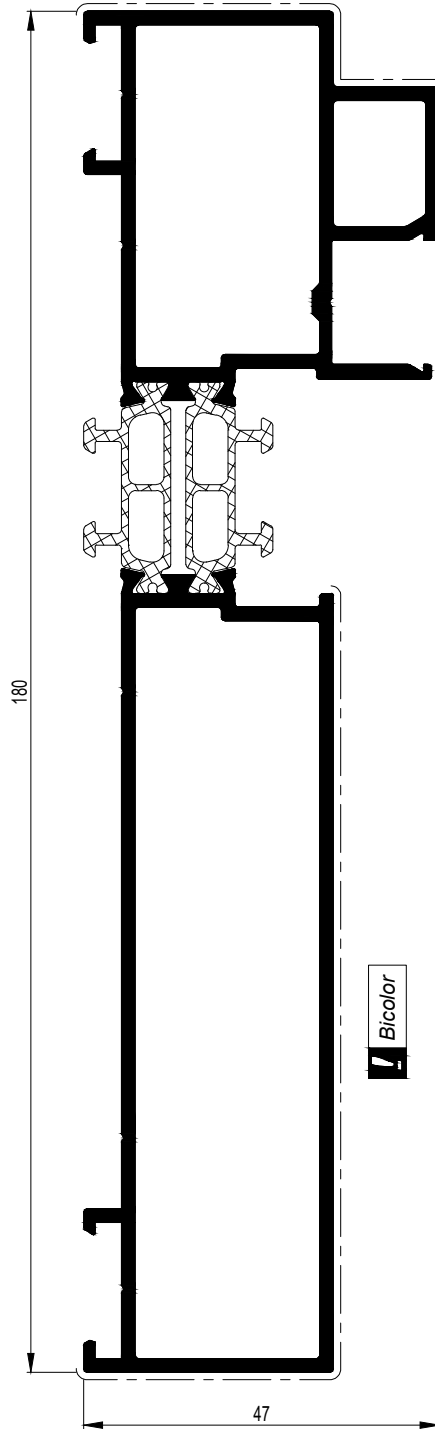
406.0327.XX  
508.8180.XX HI+





	<b>406.0327.XX</b>	
	168.7002.00 (2x) 168.8002.00 168.5000.00 (2x)	095.H800.00
	168.7102.00 168.8102.00 168.7002.00 168.5000.00 (2x)	095.H800.00
	168.7002.00 (2x) 168.8002.00 168.5000.00 (2x)	095.B500.00
	168.7102.00 168.8102.00 168.7002.00 168.5000.00 (2x)	095.B500.00
	168.7002.00 (2x) 168.8002.00 168.5000.00 (4x) 168.5012.--	---
	168.8712.00 (2x) 160.8750.-- 168.8742.00 168.5012.--	---
	160.8715.-- or 160.8716.--	097.0192.00
	168.8775.00 052.5311.--	097.0192.00
	160.8715.-- or 160.8716.--	097.0192.00
	168.8905.00 (2x) 052.5311.-- (4x)	097.0192.00
	160.8723.--	---
	160.8750.--	---

	$\frac{A}{dm^2/m}$	$\frac{P}{dm^2/m}$	$L_m$	$I_x \text{ cm}^4$	$W_x \text{ cm}^3$	ax mm	$I_y \text{ cm}^4$	$W_y \text{ cm}^3$	ay mm	
406.0525.XX	84.06	25.3	7.00/4.00/3.00	189.799	19.138	99.17	50.089	13.853	30.84	
406.0527.XX	55.93	24.1	7.00/4.00/3.00	253.406	27.985	89.45	47.085	9.262	29.17	

406.0525.XX

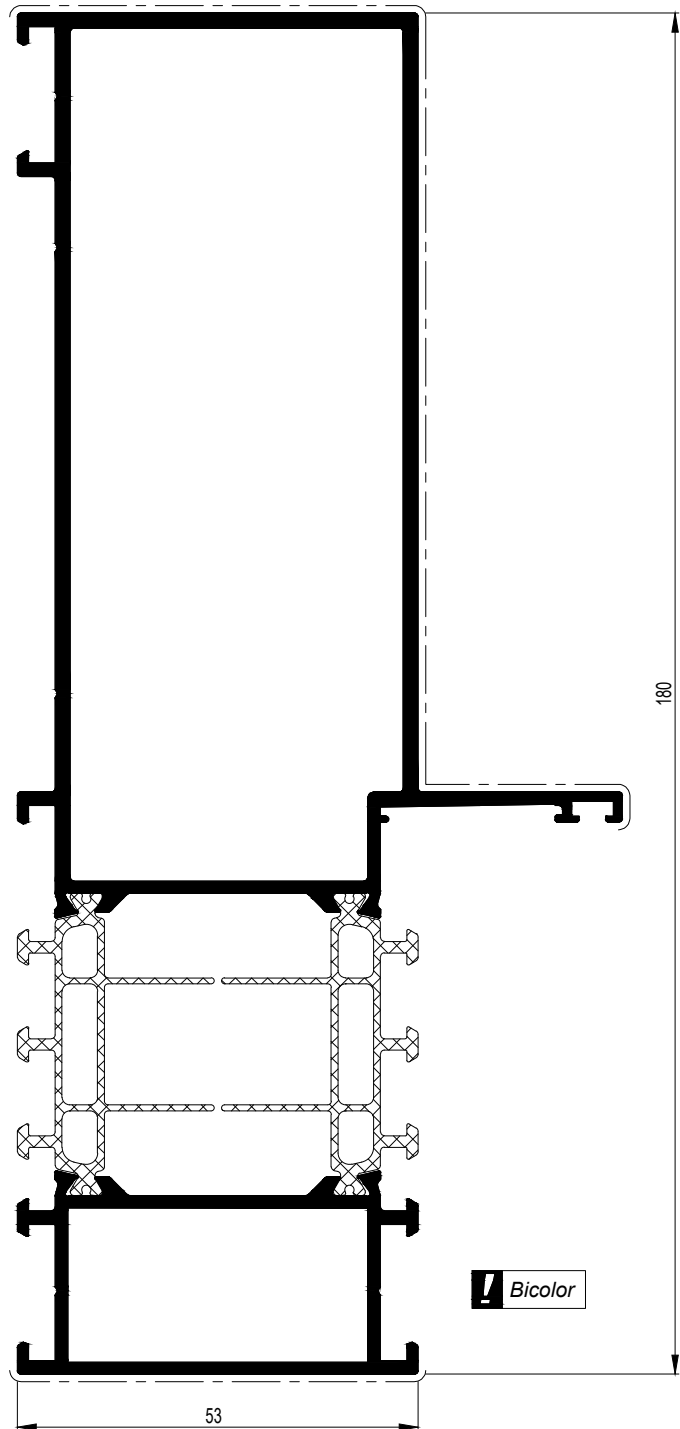
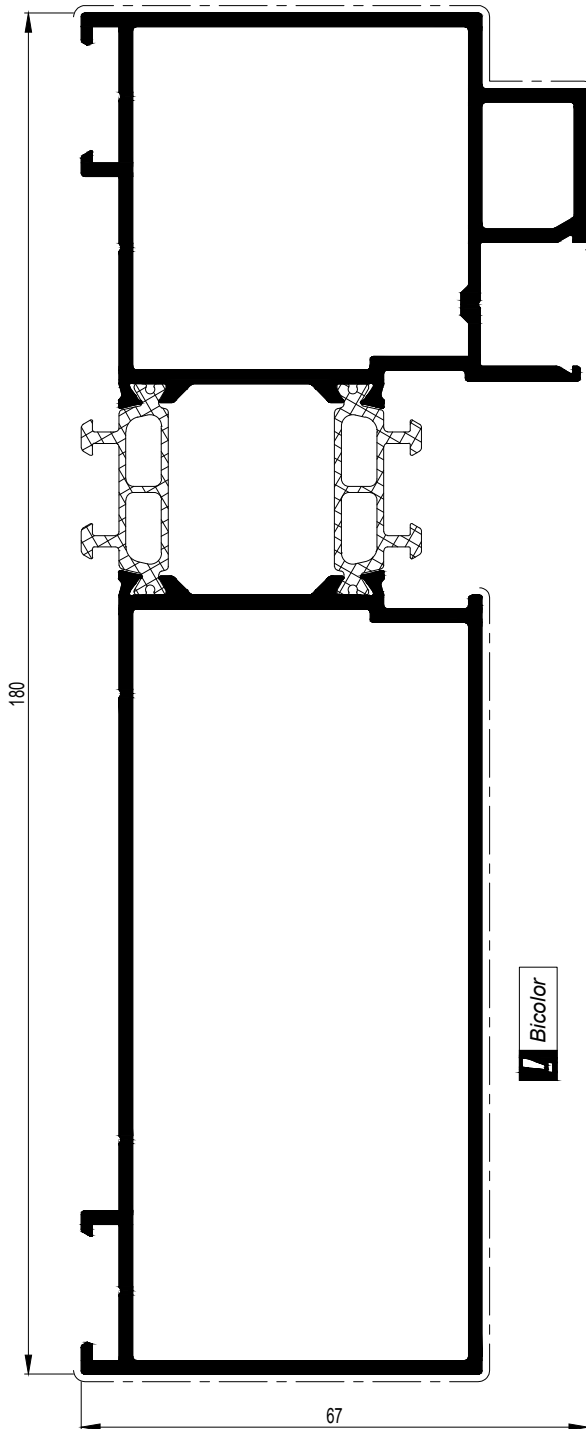
406.0527.XX



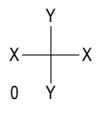

	$\frac{A}{dm^2/m}$	$\frac{P}{dm^2/m}$	$L_m$	$I_x \text{ cm}^4$	$W_x \text{ cm}^3$	ax mm	$I_y \text{ cm}^4$	$W_y \text{ cm}^3$	ay mm	
406.0345.XX	28.45	28.4	7.00/5.00	172.707	17.256	100.09	17.753	6.686	20.45	
406.0346.XX	36.19	13.1	7.00/5.00	53.909	10.288	49.10	7.633	4.285	17.81	

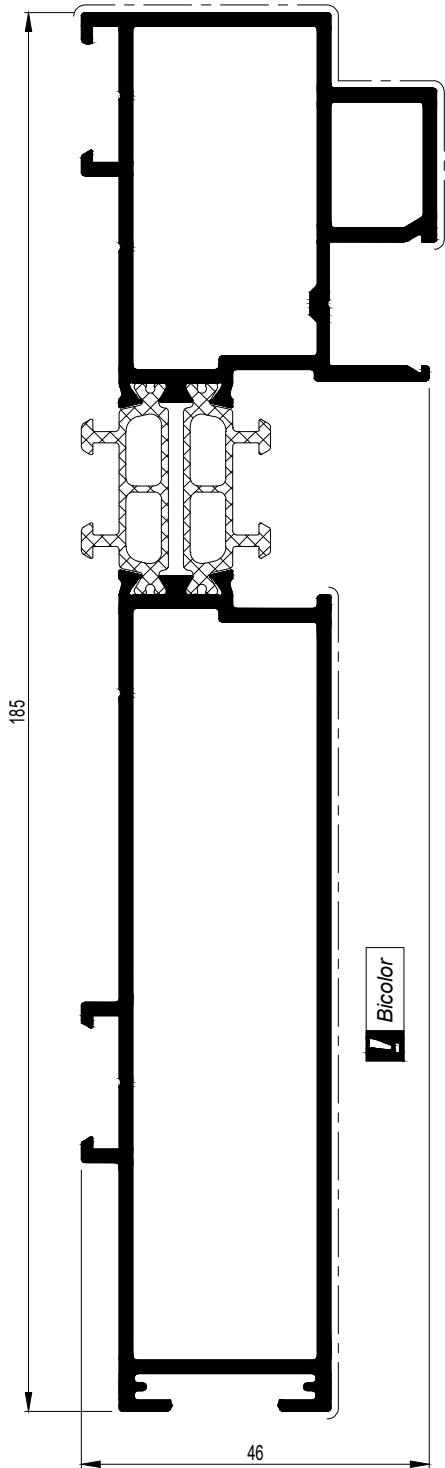
406.0345.XX

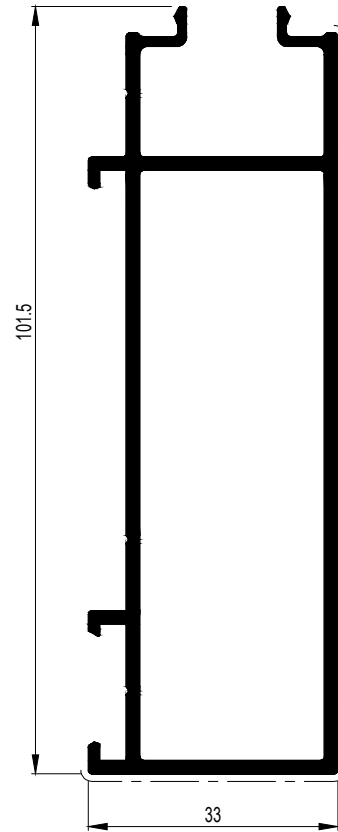

406.0346.XX



	$\frac{A}{dm^2/m}$	$\frac{P}{dm^2/m}$	$\leftarrow L_m \rightarrow$	$I_x \text{ cm}^4$	$W_x \text{ cm}^3$	ax mm	$I_y \text{ cm}^4$	$W_y \text{ cm}^3$	ay mm	
406.0320.04	0.08	0.1	7.00/5.50/4.00	3.559	1.198	19.30	2.561	1.512	16.94	
406.0324.04	0.01	-	7.00	0.241	0.277	8.70	0.111	0.122	4.84	
406.0326.04	0.02	-	7.00	1.069	0.675	14.77	0.820	0.561	11.89	
406.0322.04	-	-	7.00	1.225	0.567	20.48	0.177	0.158	6.62	
406.0319.04	0.04	-	7.00	3.597	1.392	25.84	0.306	0.309	7.98	
406.0372.04	0.01	-	7.00	0.405	0.284	14.25	0.017	0.035	1.74	

406.0320.04

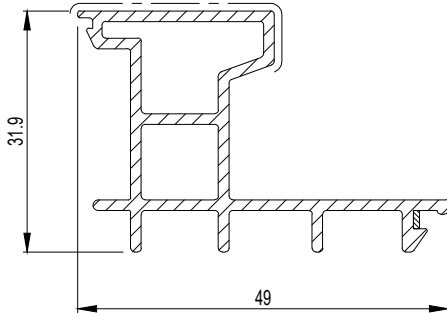

406.0324.04

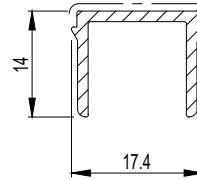

406.0326.04

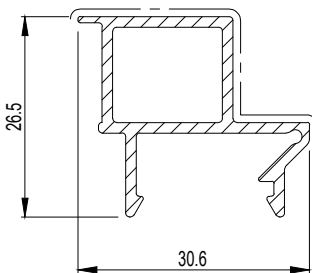

406.0319.04

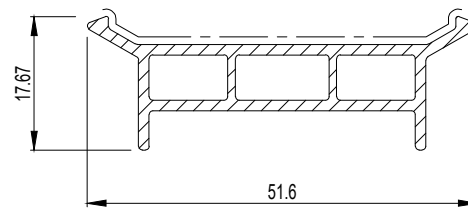

406.0322.04

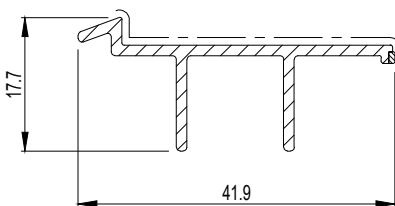

406.0372.04

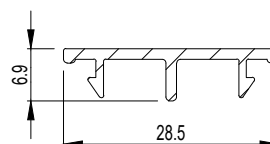

	$\frac{A}{dm^2/m}$	$\frac{P}{dm^2/m}$	$L_m$	$I_x \text{ cm}^4$	$W_x \text{ cm}^3$	ax mm	$I_y \text{ cm}^4$	$W_y \text{ cm}^3$	ay mm	
406.0365.XX	33.78	13.9	7.00/3.00	44.090	7.405	59.49	0.568	0.346	8.16	
406.0364.XX	30.52	13.2	7.00/3.00	37.279	5.833	55.12	0.548	0.414	13.23	
406.0367.XX	33.20	11.6	7.00	30.711	5.230	44.29	1.114	0.498	22.36	
406.0366.XX	36.03	13.1	7.00/3.00	29.741	5.562	53.47	3.227	1.133	28.47	

406.0365.XX

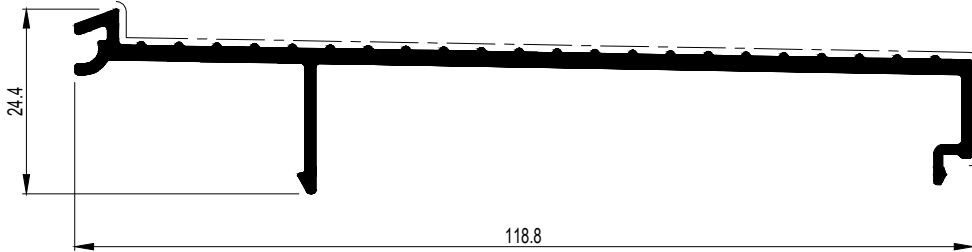

406.0364.XX

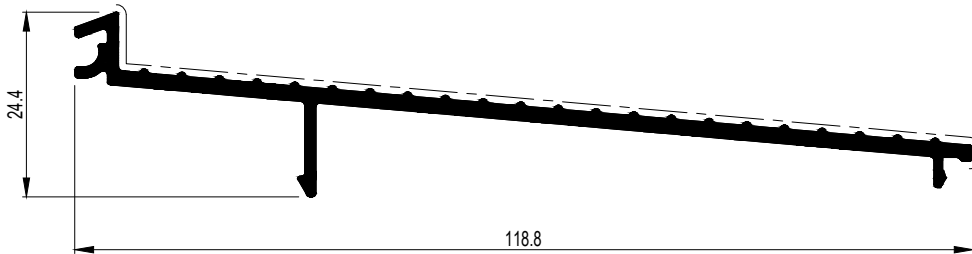

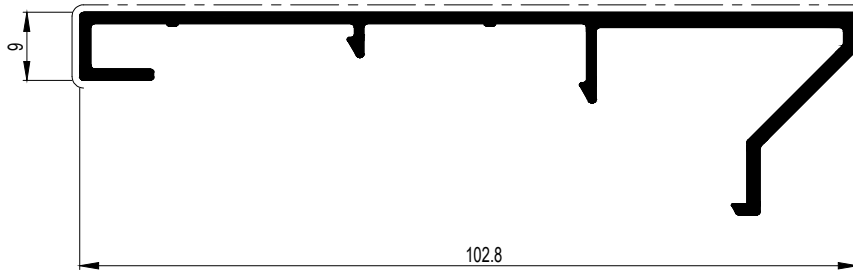

406.0367.XX

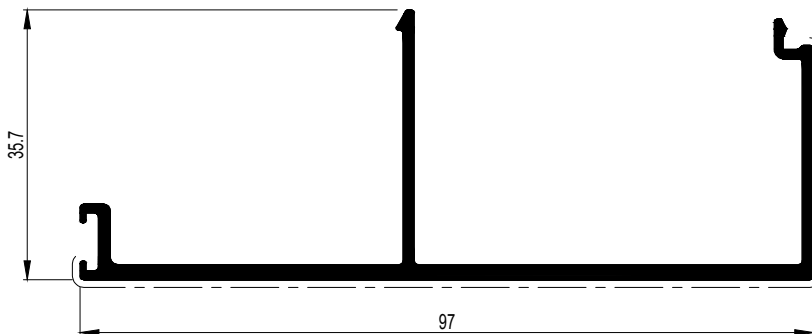

406.0366.XX



	$\frac{A}{dm^2/m}$	$\frac{P}{dm^2/m}$	$L_m$	$I_x \text{ cm}^4$	$W_x \text{ cm}^3$	ax mm	$I_y \text{ cm}^4$	$W_y \text{ cm}^3$	ay mm	
406.0363.XX	33.43	11.5	7.00/3.00	29.724	5.474	42.70	1.184	0.514	5.70	
406.0337.XX	36.74	13.8	7.00/3.00	30.412	5.717	53.20	3.274	1.146	28.56	
406.0369.XX	32.27	11.1	7.00	1.266	0.526	24.07	32.781	5.328	43.56	
406.0371.XX	10.90	5.0	3.00	1.732	0.737	23.50	0.010	0.025	4.26	

406.0363.XX

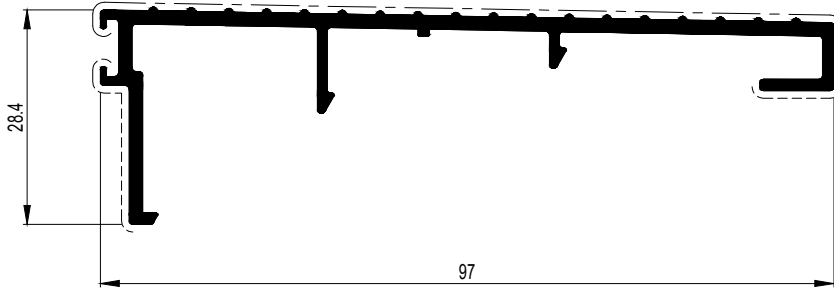

406.0337.XX

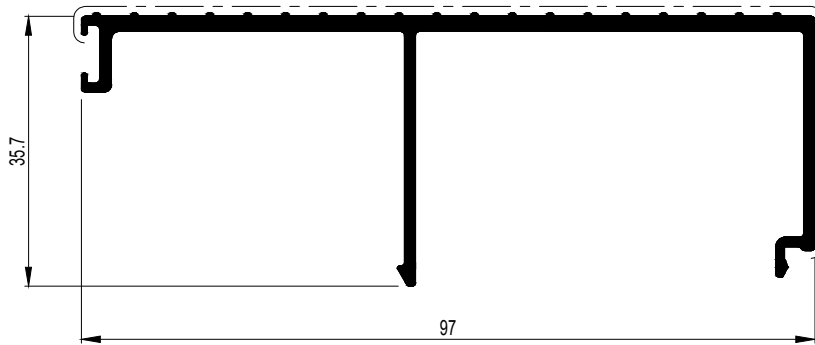

406.0369.XX

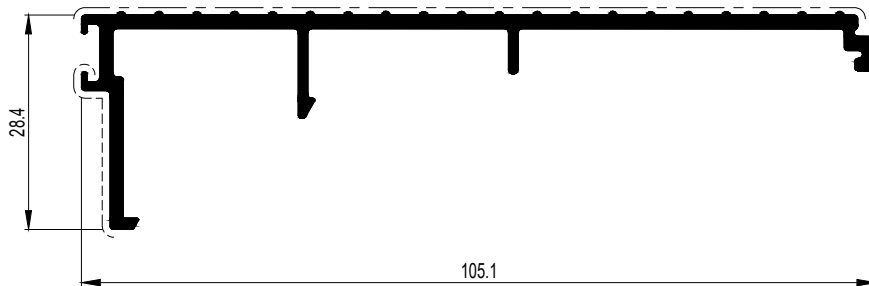

406.0371.XX

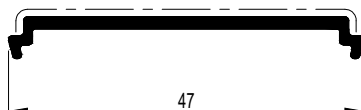

		$\frac{A}{dm^2/m}$	$\frac{P}{dm^2/m}$	$\leftarrow L_m \rightarrow$	$I_x \text{ cm}^4$	$W_x \text{ cm}^3$	ax mm	$I_y \text{ cm}^4$	$W_y \text{ cm}^3$	ay mm	
406.0340.XX		38.92	31.7	7.00/5.50	28.050	6.729	35.52	20.342	4.246	39.30	
406.0343.04		-	-	7.00	2.024	0.852	23.75	0.299	0.230	4.11	

406.0340.XX

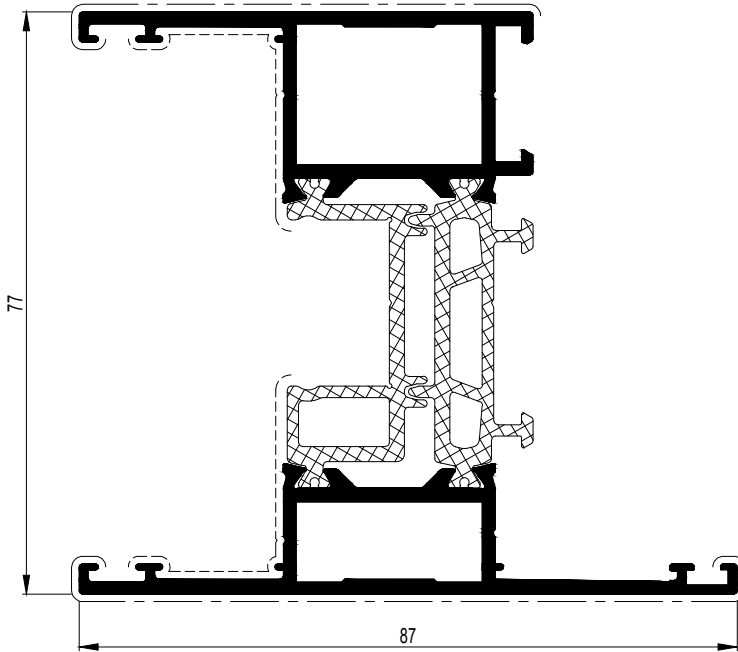

406.0343.04

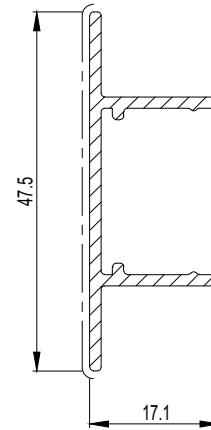

Speciale isolatie in de buitenschaal, het profiel is flexibel  
 Isolation spéciale dans la demi-coquille extérieure, le profilé est souple  
 Special insulation in the external half-scale, the profile is flexible  
 Spezialisierung in der äußeren Halbschale, das Profil ist flexibel

	<b>406.0340.XX</b>	
	168.8105.00	
	168.8106.00	
	160.8725.--	

	$\frac{A}{dm^2/m}$	$\frac{P}{dm^2/m}$	$L_m$	$I_x \text{ cm}^4$	$W_x \text{ cm}^3$	ax mm	$I_y \text{ cm}^4$	$W_y \text{ cm}^3$	ay mm	
406.0335.XX	32.62	11.2	7.00/5.50	21.979	5.214	34.85	10.955	2.591	42.29	
406.0342.XX	28.19	12.0	7.00/5.50	28.356	5.020	40.74	1.126	0.545	4.37	
406.0341.04	0.08	0.1	7.00	2.347	1.009	14.99	6.979	2.510	27.81	
406.0351.04PU	0.01	-	7.00	1.550	0.748	12.19	4.564	1.625	28.09	

406.0335.XX

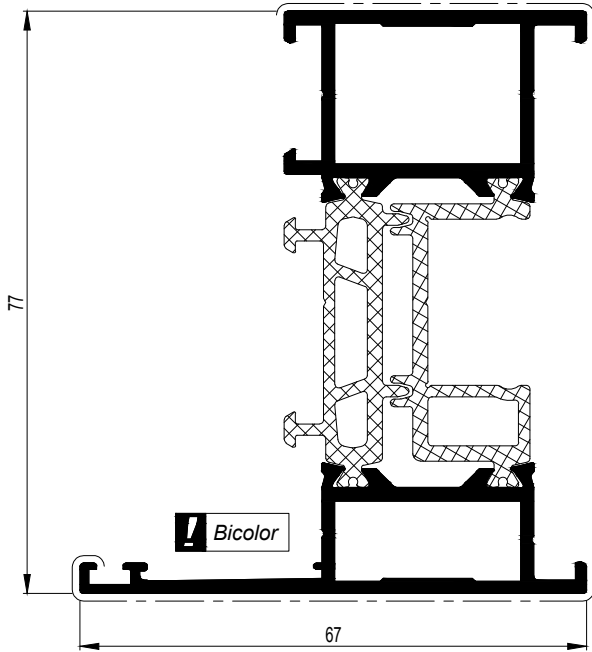

406.0342.XX

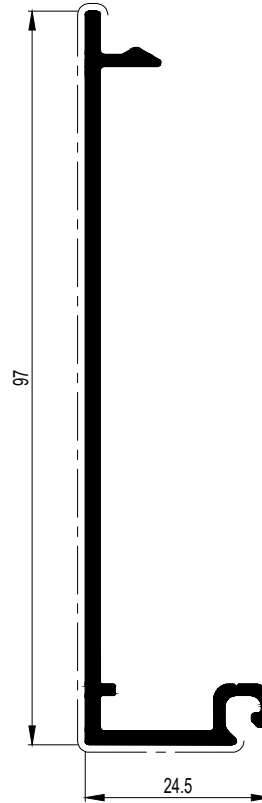

406.0341.04PU

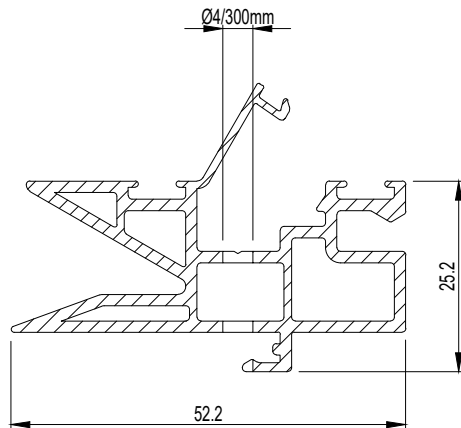

406.0351.04PU

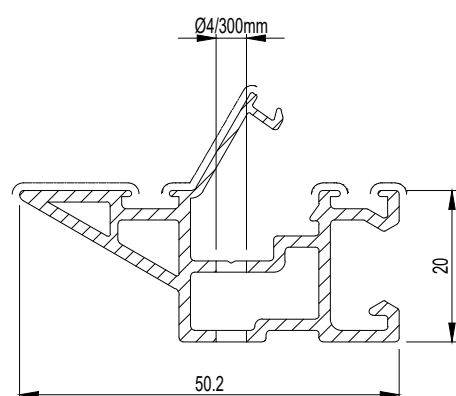

	<b>406.0335.XX</b>	
	168.8106.00	---
	168.8105.00	---
	160.8725.--	---

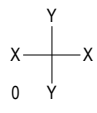
	$\frac{A}{dm^2/m}$	$\frac{P}{dm^2/m}$	$\leftarrow L_m \rightarrow$	$I_x \text{ cm}^4$	$W_x \text{ cm}^3$	ax mm	$I_y \text{ cm}^4$	$W_y \text{ cm}^3$	ay mm	
406.0330.XX	23.90	10.0	7.00/5.50	20.340	5.160	37.79	2.050	0.873	23.47	
406.0332.XX	26.64	11.3	7.00/5.50	26.208	4.817	42.82	0.528	0.335	3.28	
406.0331.04PU	0.01	-	7.00	2.668	1.539	14.37	2.212	1.066	13.12	

406.0330.XX

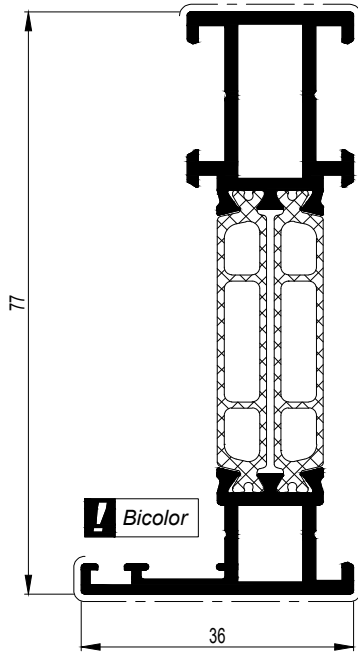



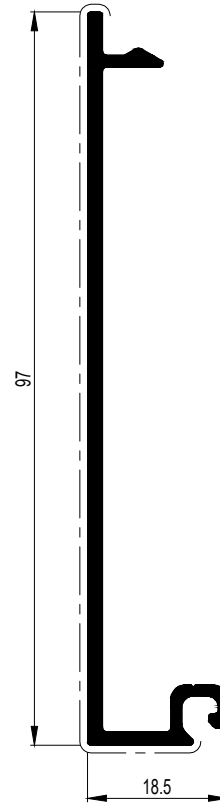

406.0332.XX

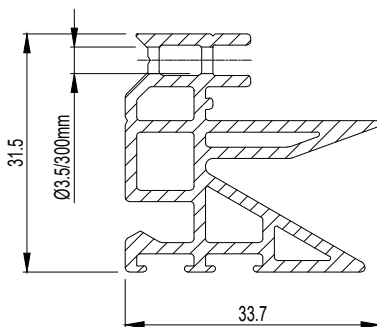

406.0331.04PU



	<b>406.0330.XX</b>	
	068.8932.00	---
	168.8725.00	---

	$\frac{A}{dm^2/m}$	$\frac{P}{dm^2/m}$	$L_m$	$I_x \text{ cm}^4$	$W_x \text{ cm}^3$	ax mm	$I_y \text{ cm}^4$	$W_y \text{ cm}^3$	ay mm	Y X 0 Y
406.0350.XX	27.90	17.9	7.00/5.50	22.815	5.382	34.82	3.171	1.263	25.10	X Y
408.0120.XX	35.38	12.9	7.00/5.00	26.409	5.832	31.72	14.154	3.254	43.50	0 Y

406.0350.XX

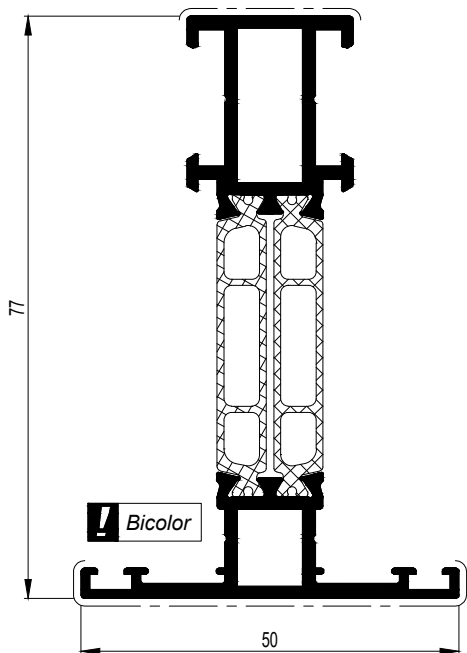

408.0120.XX L=7.00m

4K8.0120.XX L=1.30m

508.0120.XX HI+

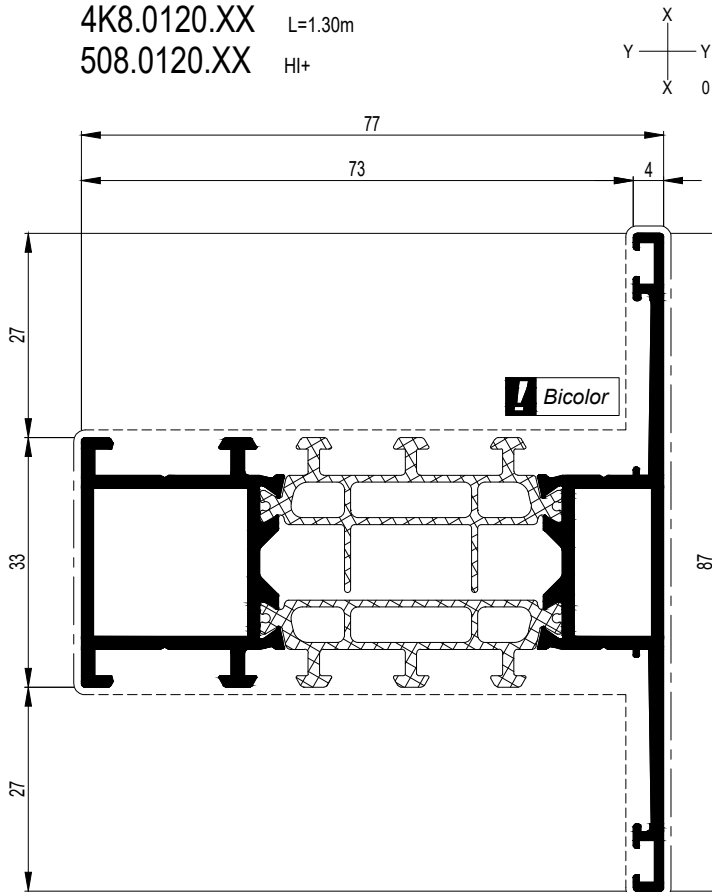

C

	408.0120.XX	
	168.7002.00	095.H800.00
	168.8002.00	095.H800.00
	168.7102.00	095.H800.00
	168.8102.00	095.H800.00
	168.7002.00	095.B500.00
	168.8002.00	095.B500.00
	168.7102.00	095.B500.00
	168.8102.00	095.B500.00
	168.7002.00	197.B600.00
	168.8002.00	of-ou-or-oder
	168.5000.00 (2x)	097.0205.00
	168.5012.--	
	168.8686.04 (2x)	
	168.8712.00	197.B600.00
	160.8750.-- (2x)	of-ou-or-oder
	168.8742.00 (opt)	097.0205.00
	168.5012.-- (opt)	
	160.8715.--	097.0192.00
	160.8716.--	097.0192.00
	168.8775.00	097.0192.00
	---	
	052.5311.--	
	050.5094.--	
	053.5405.-- (2x)	
	160.8715.--	097.0192.00
	160.8716.--	097.0192.00
	168.8905.00	097.0192.00
	---	
	052.5311.-- (2x)	
	050.5094.-- (2x)	
	160.8723.-- (2x)	
	160.8750.-- (2x)	

	406.0350.XX	
	068.8932.00	
	168.8725.00	

	$\frac{A}{dm^2/m}$	$\frac{P}{dm^2/m}$	$\leftarrow L_m \rightarrow$	$I_x \text{ cm}^4$	$W_x \text{ cm}^3$	ax mm	$I_y \text{ cm}^4$	$W_y \text{ cm}^3$	ay mm	
406.0360.XX	50.65	28.8	7.00/5.50	213.008	20.983	101.51	29.559	11.823	25.00	
406.0997.XX	26.73	8.0	4.00	16.618	4.873	34.10	8.875	4.329	20.50	
0M0.1505.XX	4.00	4.0	6.00	0.140	0.187	7.50	0.015	0.062	2.50	
406.0315.XX	39.71	25.4	7.00/4.00	78.897	13.628	45.11	24.469	4.545	21.17	

406.0360.XX

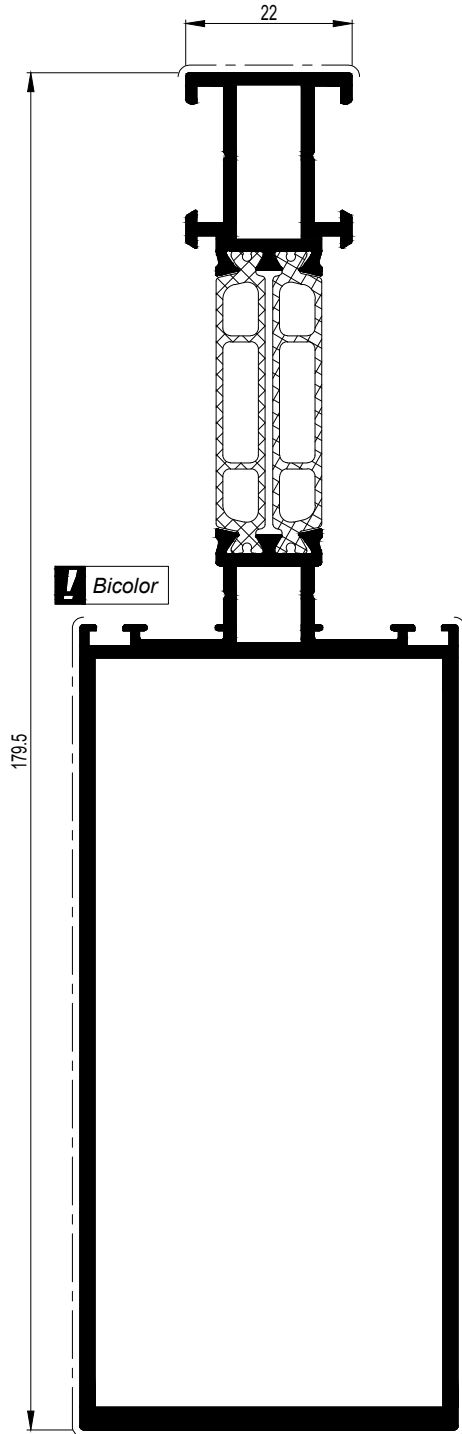

406.0997.XX

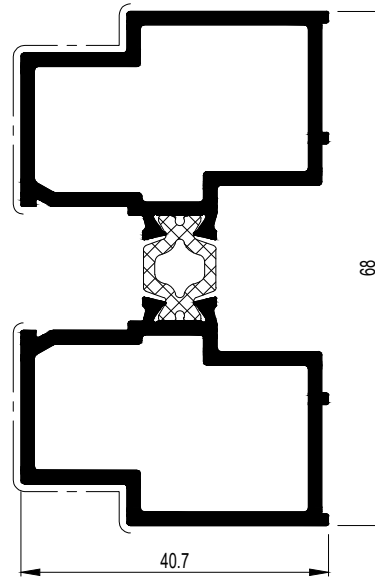

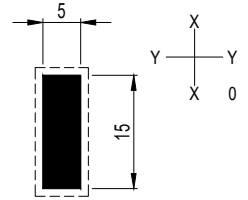

0M0.1505.XX

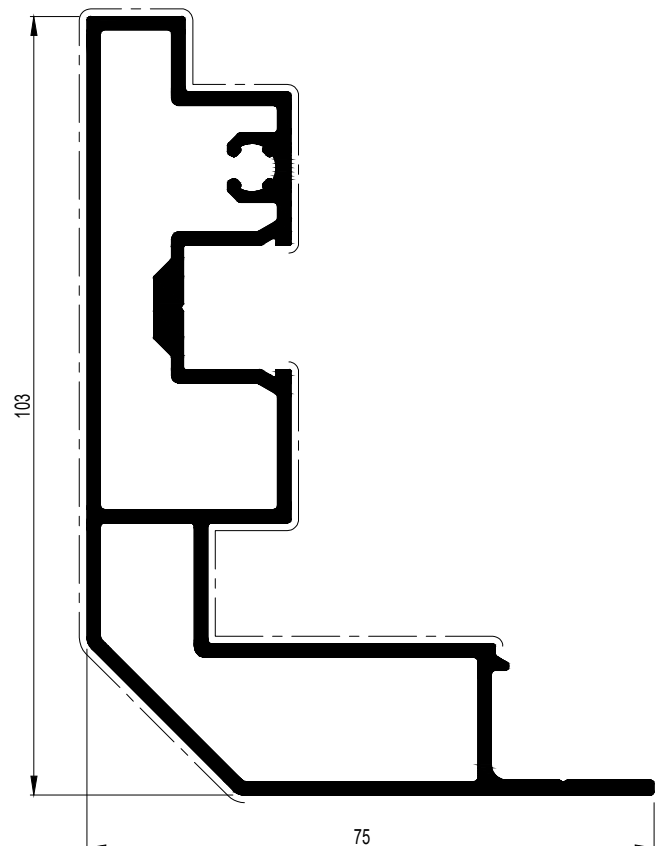

406.0315.XX



	$\frac{A}{dm^2/m}$	$\frac{P}{dm^2/m}$	$L_m$	$I_x \text{ cm}^4$	$W_x \text{ cm}^3$	ax mm	$I_y \text{ cm}^4$	$W_y \text{ cm}^3$	ay mm	
030.3606.XX	12.37	3.4	7.00	0.277	0.198	13.99	0.919	0.612	14.14	
030.3607.XX	15.10	3.7	7.00	0.333	0.255	13.05	0.894	0.581	15.39	
030.3608.XX	15.09	4.0	7.00	0.431	0.355	12.13	0.914	0.559	16.34	
030.3609.XX	15.54	4.3	7.00	0.548	0.485	11.28	0.970	0.576	16.85	
030.3610.XX	16.16	4.6	7.00	0.690	0.644	10.71	1.019	0.590	17.26	
030.3611.XX	16.91	4.9	7.00	0.874	0.689	12.68	1.072	0.608	17.64	
030.3612.XX	18.96	5.2	7.00	0.995	0.670	14.85	1.148	0.619	18.53	
130.3644.XX	10.17	2.8	7.00	0.549	0.296	9.86	0.311	0.232	5.79	
130.3645.XX	10.75	3.1	7.00	0.717	0.415	11.13	0.314	0.231	5.64	

130.3644.XX

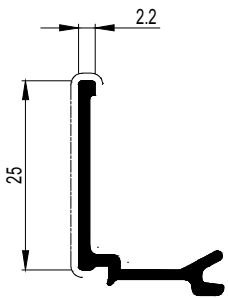

130.3645.XX

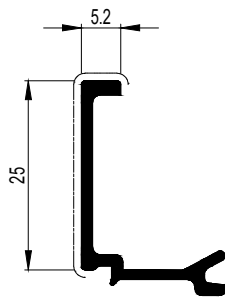

030.3606.XX

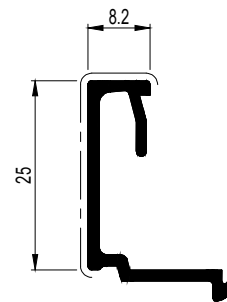

030.3607.XX

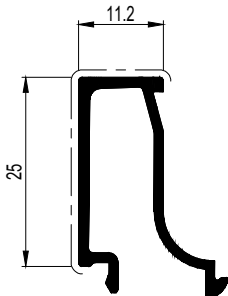

030.3608.XX

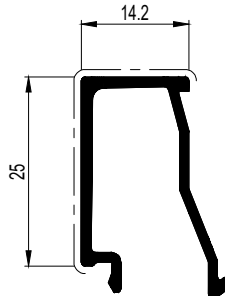

030.3609.XX

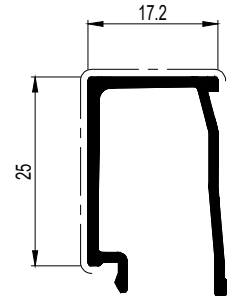

030.3610.XX

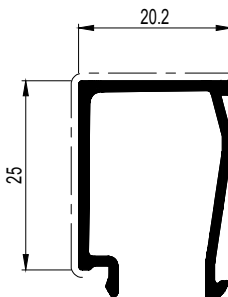

030.3611.XX

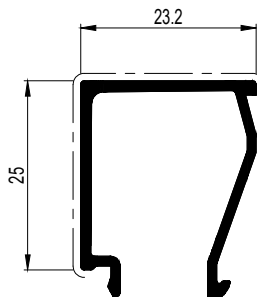

030.3612.XX

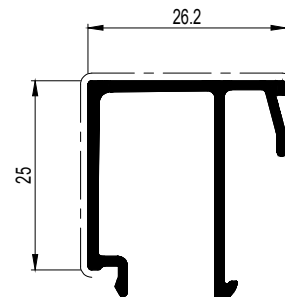

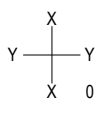
	$\frac{A}{dm^2/m}$	$\frac{P}{dm^2/m}$	$\leftarrow L_m \rightarrow$	$I_x \text{ cm}^4$	$W_x \text{ cm}^3$	ax mm	$I_y \text{ cm}^4$	$W_y \text{ cm}^3$	ay mm	
030.3613.XX	19.56	5.5	7.00	1.191	0.696	17.13	1.183	0.629	18.81	
030.3614.XX	20.15	5.8	7.00	1.437	0.741	19.40	1.218	0.640	19.03	
030.3615.XX	20.83	6.1	7.00	1.756	0.824	21.32	1.254	0.650	19.30	
030.3616.XX	21.68	6.4	7.00	2.196	0.962	22.84	1.329	0.668	19.90	
030.3617.XX	22.47	6.7	7.00	2.617	1.057	24.76	1.365	0.674	20.24	
030.3618.XX	23.28	7.0	7.00	3.098	1.164	26.63	1.400	0.684	20.46	
030.3619.XX	23.62	7.3	7.00	3.542	1.224	28.93	1.424	0.692	20.59	
030.3622.XX	24.25	7.6	7.00	4.085	1.316	31.03	1.446	0.695	20.80	

030.3613.XX

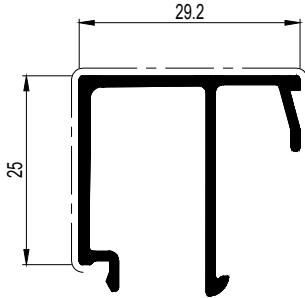

030.3614.XX

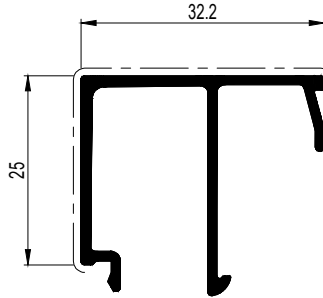

030.3615.XX

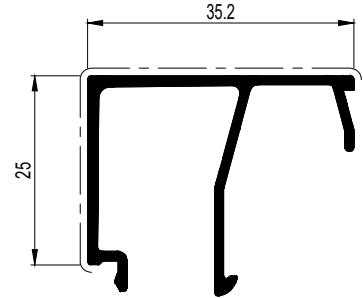

030.3616.XX

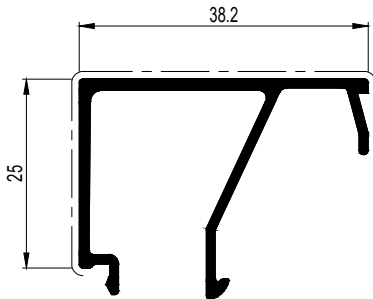

030.3617.XX

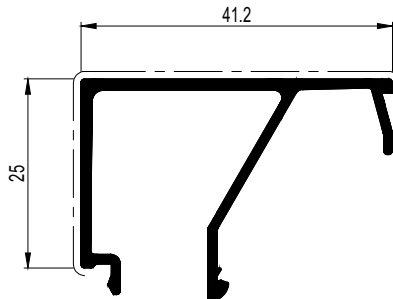

030.3618.XX

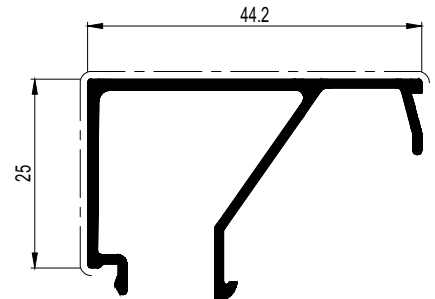

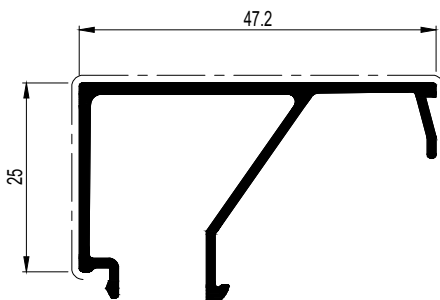

030.3619.XX

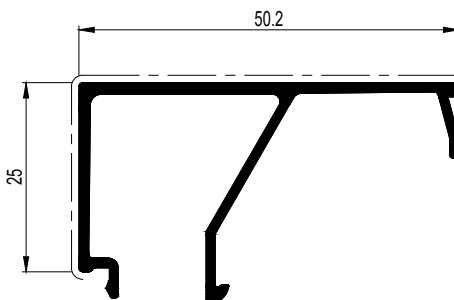

030.3622.XX



	$\frac{A}{dm^2/m}$	$\frac{P}{dm^2/m}$	$L_m$	$I_x \text{ cm}^4$	$W_x \text{ cm}^3$	ax mm	$I_y \text{ cm}^4$	$W_y \text{ cm}^3$	ay mm	
030.3620.XX	25.50	8.2	7.00	5.328	1.501	35.49	1.481	0.703	21.08	
030.3623.XX	24.82	7.9	7.00	4.685	1.416	33.09	1.473	0.703	20.97	

030.3623.XX

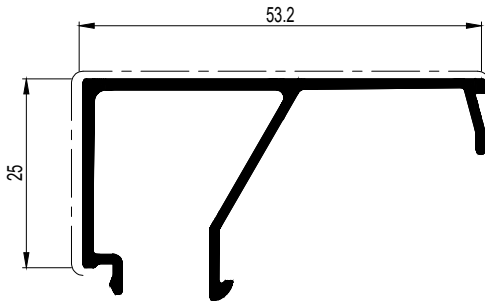

030.3620.XX

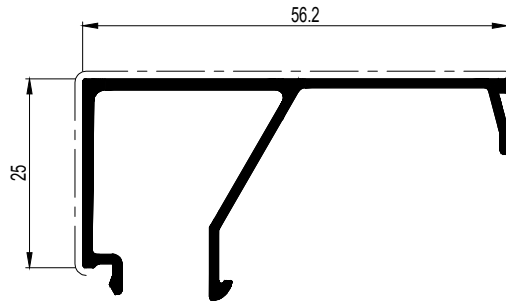

	$\frac{A}{dm^2/m}$	$\frac{P}{dm^2/m}$	$\leftarrow L_m \rightarrow$	$I_x \text{ cm}^4$	$W_x \text{ cm}^3$	ax mm	$I_y \text{ cm}^4$	$W_y \text{ cm}^3$	ay mm	
130.3644.XX	10.17	2.8	7.00	0.549	0.296	9.86	0.311	0.232	5.79	
130.3645.XX	10.75	3.1	7.00	0.717	0.415	11.13	0.314	0.231	5.64	
130.3646.XX	12.99	3.4	7.00	0.936	0.612	13.10	0.316	0.237	5.86	
130.3647.XX	9.53	3.7	7.00	1.040	0.687	13.29	0.372	0.308	7.28	
130.3648.XX	9.71	4.1	7.00	1.121	0.773	13.91	0.459	0.413	8.10	
130.3649.XX	9.73	4.3	7.00	1.174	0.804	14.61	0.546	0.520	8.70	
130.3650.XX	10.20	4.6	7.00	1.266	0.851	14.88	0.741	0.715	9.84	
130.3651.XX	10.73	4.9	7.00	1.324	0.862	15.37	0.900	0.721	10.71	
130.3652.XX	11.28	5.2	7.00	1.387	0.880	15.75	1.130	0.780	11.71	
130.3653.XX	11.83	5.5	7.00	1.445	0.897	16.11	1.412	0.858	12.74	
130.3654.XX	12.38	5.8	7.00	1.500	0.912	16.44	1.747	0.949	13.80	
130.3655.XX	12.93	6.1	7.00	1.552	0.926	16.76	2.139	1.053	14.89	

130.3644.XX

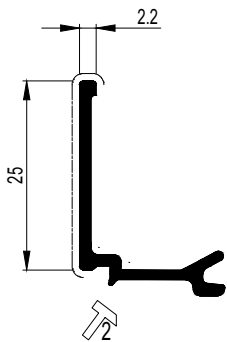

130.3645.XX

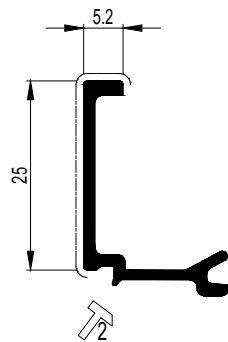

130.3646.XX

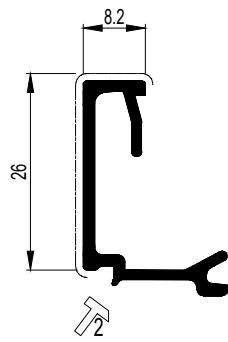

130.3647.XX

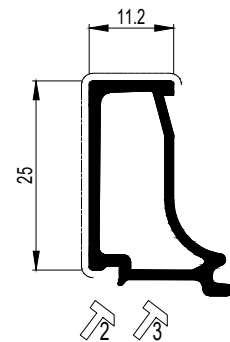

130.3648.XX

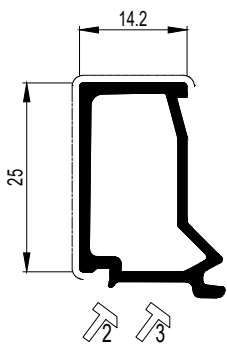

130.3649.XX

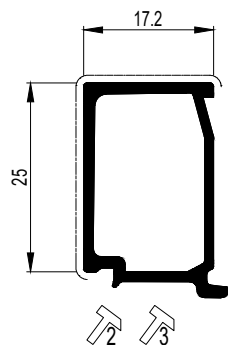

130.3650.XX

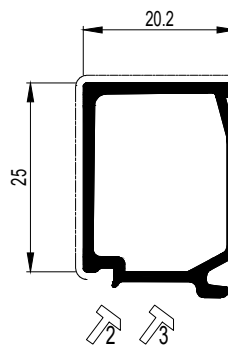

130.3651.XX

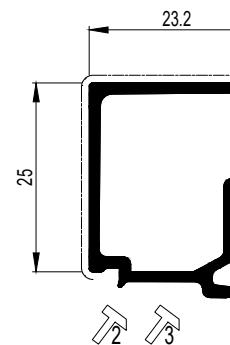

130.3652.XX

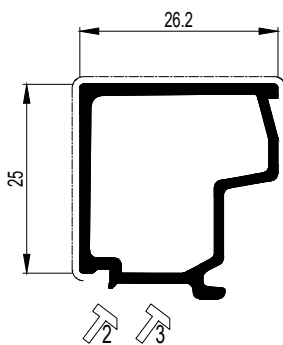

130.3653.XX

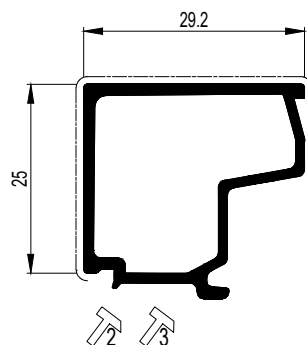

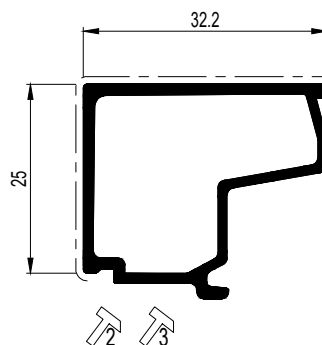

130.3654.XX

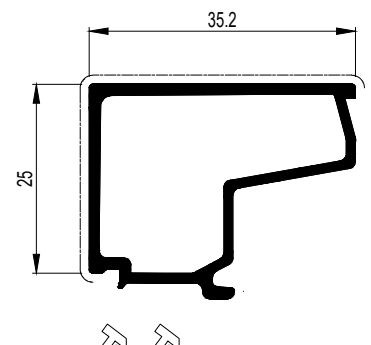

130.3655.XX



	$\frac{A}{dm^2/m}$	$\frac{P}{dm^2/m}$	$L_m$	$I_x \text{ cm}^4$	$W_x \text{ cm}^3$	ax mm	$I_y \text{ cm}^4$	$W_y \text{ cm}^3$	ay mm	
130.3656.XX	14.21	6.4	7.00	1.663	0.945	17.59	2.064	0.871	14.51	
130.3657.XX	14.81	6.7	7.00	1.705	0.955	17.85	2.424	0.935	15.28	
130.3658.XX	15.41	7.0	7.00	1.745	0.964	18.09	2.840	1.010	16.08	
130.3659.XX	16.01	7.3	7.00	1.782	0.973	18.32	3.316	1.095	16.92	

130.3656.XX

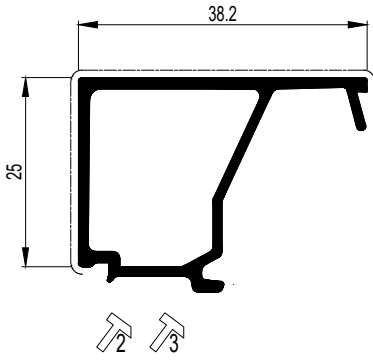

130.3657.XX

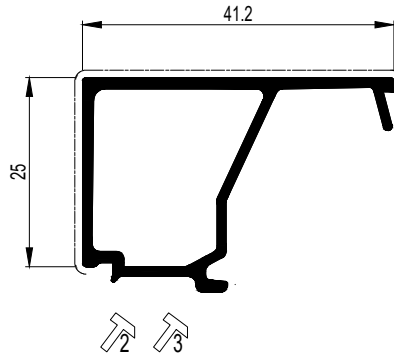

130.3658.XX

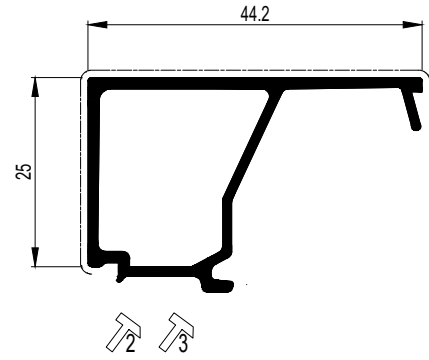

130.3659.XX

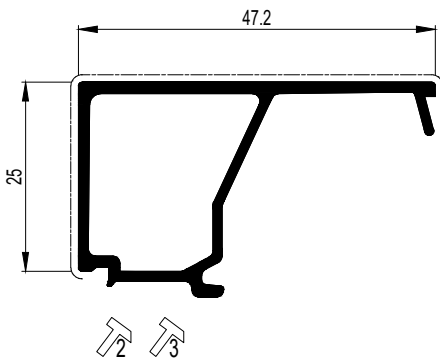

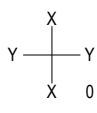
	$\frac{A}{dm^2/m}$	$\frac{P}{dm^2/m}$	$\leftarrow L_m \rightarrow$	$I_x \text{ cm}^4$	$W_x \text{ cm}^3$	ax mm	$I_y \text{ cm}^4$	$W_y \text{ cm}^3$	ay mm	
002.0673.XX	10.68	2.5	7.00	0.239	0.194	12.29	0.227	0.227	10.01	
002.0674.XX	10.90	2.8	7.00	0.286	0.248	11.51	0.239	0.226	10.59	
002.0675.XX	11.25	3.1	7.00	0.349	0.325	10.72	0.254	0.230	11.04	
002.0682.XX	11.82	3.4	7.00	0.431	0.431	9.81	0.266	0.237	7.06	
002.0693.XX	13.49	3.7	7.00	0.547	0.456	12.01	0.291	0.245	11.88	
002.0683.XX	14.08	4.1	7.00	0.669	0.466	14.36	0.300	0.249	12.07	
002.0687.XX	14.68	4.4	7.00	0.822	0.499	12.82	0.311	0.253	6.01	
002.0686.XX	15.28	4.7	7.00	1.011	0.545	13.74	0.321	0.257	5.81	
002.0688.XX	15.88	5.0	7.00	1.237	0.601	14.71	0.331	0.261	5.62	

002.0673.XX

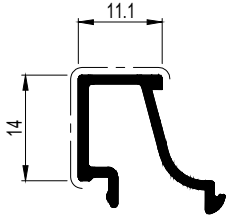

002.0674.XX

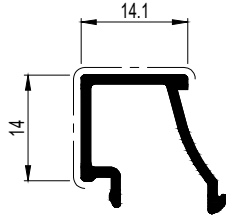

002.0675.XX

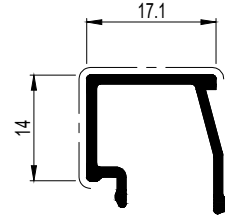

002.0682.XX

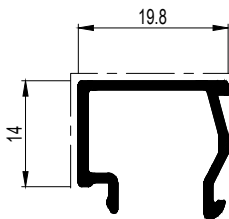

002.0693.XX

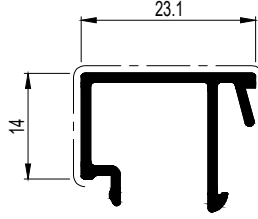

002.0683.XX

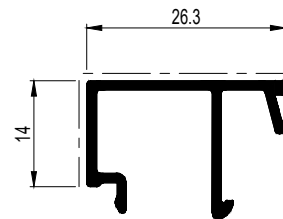

002.0687.XX

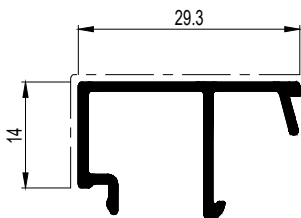

002.0686.XX

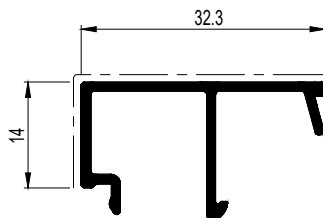

002.0688.XX

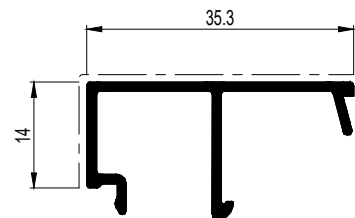

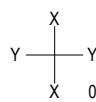
	$\frac{A}{dm^2/m}$	$\frac{P}{dm^2/m}$	$\leftarrow L_m \rightarrow$	$I_x \text{ cm}^4$	$W_x \text{ cm}^3$	ax mm	$I_y \text{ cm}^4$	$W_y \text{ cm}^3$	ay mm	
002.0609.XX	7.95	1.8	6.00	0.189	0.182	7.79	0.227	0.175	6.39	
002.0678.XX	7.69	2.8	7.00	0.259	0.247	10.50	0.298	0.320	9.32	
002.0679.XX	7.93	3.1	7.00	0.322	0.330	9.75	0.323	0.333	9.68	
002.0680.XX	8.36	3.4	7.00	0.421	0.420	10.01	0.351	0.355	9.88	
002.0681.XX	10.43	3.7	7.00	0.532	0.442	12.06	0.376	0.367	10.24	
002.0689.XX	11.31	4.3	7.00	0.772	0.449	17.20	0.409	0.377	10.85	
002.0690.XX	12.22	4.9	7.00	1.126	0.515	21.87	0.439	0.390	11.25	
002.0691.XX	12.02	4.6	7.00	0.993	0.515	19.27	0.425	0.384	11.07	
002.0692.XX	10.80	4.0	7.00	0.629	0.425	14.82	0.388	0.362	10.70	
002.0696.XX	12.84	5.2	7.00	1.618	0.716	22.61	0.473	0.413	11.45	
002.0697.XX	13.44	5.5	7.00	1.940	0.785	24.72	0.486	0.418	11.63	
002.1676.XX	9.59	2.2	7.00	0.210	0.164	12.78	0.235	0.254	9.03	
002.1677.XX	10.19	2.5	7.00	0.222	0.181	12.29	0.264	0.277	9.53	

002.0609.XX

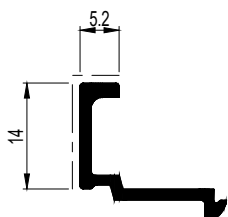

002.1676.XX

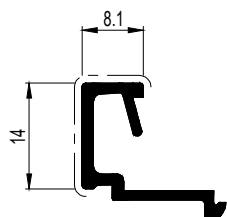

002.1677.XX

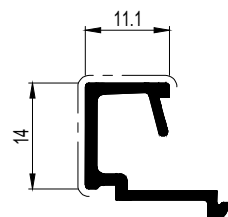

002.0678.XX

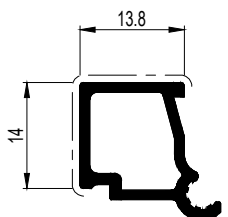

002.0679.XX

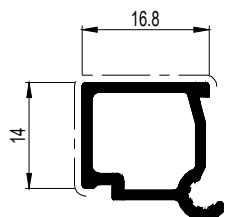

002.0680.XX

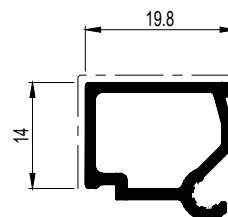

002.0681.XX

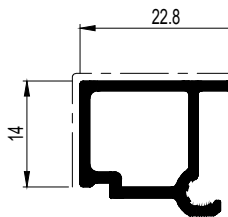

002.0692.XX

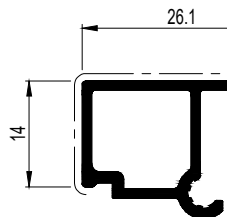

002.0689.XX

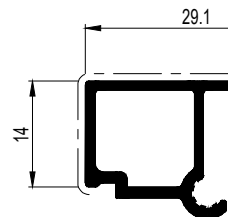

002.0691.XX

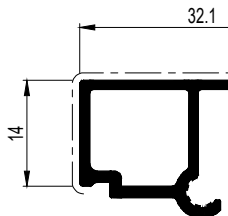

002.0690.XX

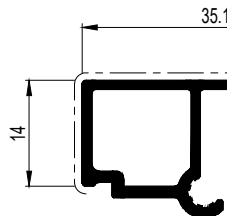

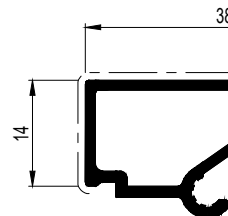

002.0696.XX

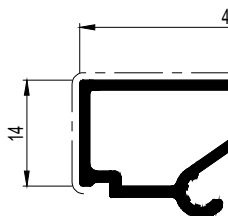

002.0697.XX



	$\frac{A}{dm^2/m}$	$\frac{P}{dm^2/m}$	$L_m$	$I_x \text{ cm}^4$	$W_x \text{ cm}^3$	ax mm	$I_y \text{ cm}^4$	$W_y \text{ cm}^3$	ay mm	
011.4633.--	0.03	-	7.00	0.007	0.030	2.50	0.019	0.035	5.24	

011.4633.--

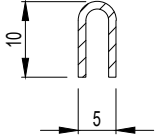

C

	$\frac{A}{dm^2/m}$	$\frac{P}{dm^2/m}$	$\leftarrow L_m \rightarrow$	$I_x \text{ cm}^4$	$W_x \text{ cm}^3$	ax mm	$I_y \text{ cm}^4$	$W_y \text{ cm}^3$	ay mm	
406.0080.00PU	11.77	-	7.00	0.095	0.258	3.69	5.227	2.215	23.60	
406.0081.XX	13.79	7.0	7.00	0.062	0.077	1.95	3.244	1.298	25.00	
406.0090.00PU	14.37	-	7.00	4.081	2.771	14.73	10.352	4.407	23.49	
406.0091.XX	22.33	11.0	7.00	1.629	0.756	21.55	7.878	3.138	25.10	
406.0092.00PU	18.57	-	7.00	17.098	6.804	25.13	15.784	6.720	23.49	
406.0093.XX	30.18	15.0	7.00	7.039	2.099	33.53	11.816	4.707	25.10	

406.0080.00PU

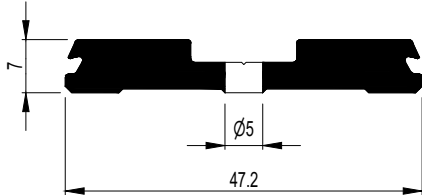

406.0081.XX

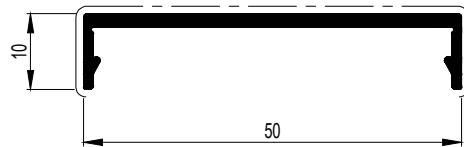

406.0090.00PU

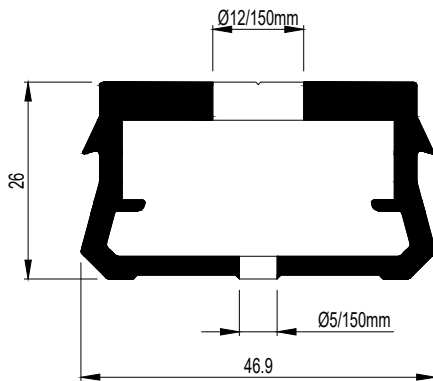

406.0091.XX

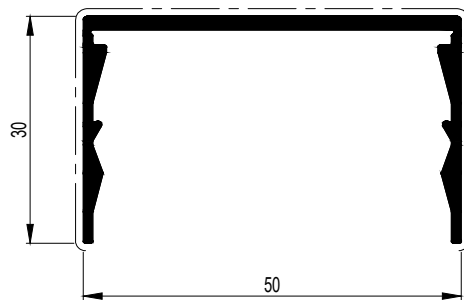

406.0092.00PU

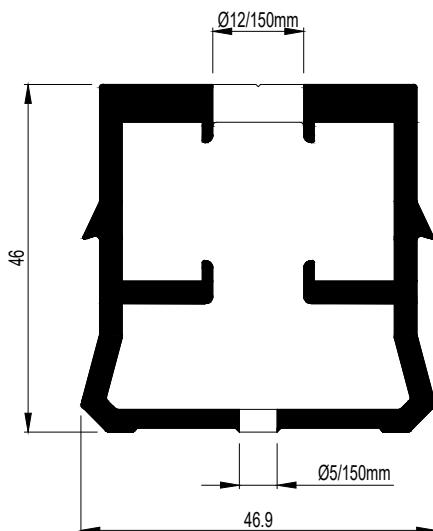

406.0093.XX

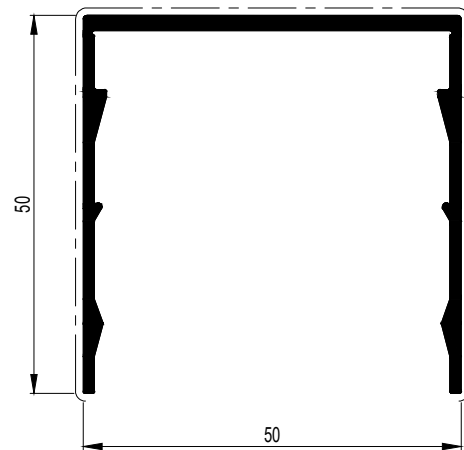

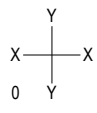
	$\frac{A}{dm^2/m}$	$\frac{P}{dm^2/m}$	$\leftarrow L_m \rightarrow$	$I_x \text{ cm}^4$	$W_x \text{ cm}^3$	ax mm	$I_y \text{ cm}^4$	$W_y \text{ cm}^3$	ay mm	
406.0094.00PU	22.37	-	7.00	40.667	10.993	36.99	20.356	8.666	23.49	
406.0096.00	21.45	-	7.00	7.093	4.586	15.47	56.439	13.769	40.99	
406.0095.XX	38.18	19.0	7.00	17.420	3.872	44.99	15.346	6.113	25.10	
406.0097.XX	29.92	14.5	7.00	1.919	0.816	23.52	27.252	6.397	42.60	

406.0094.00PU

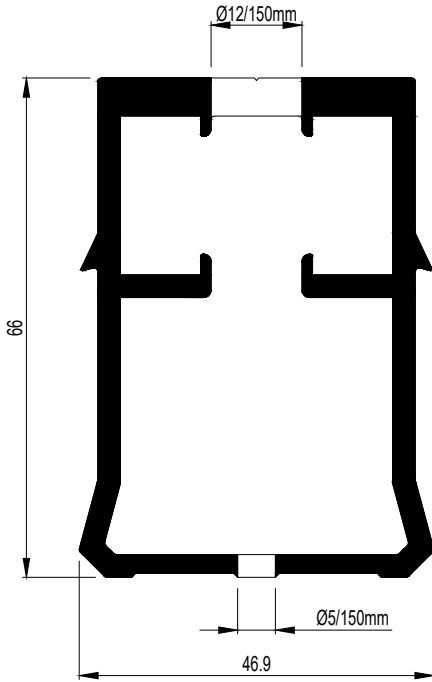

406.0095.XX

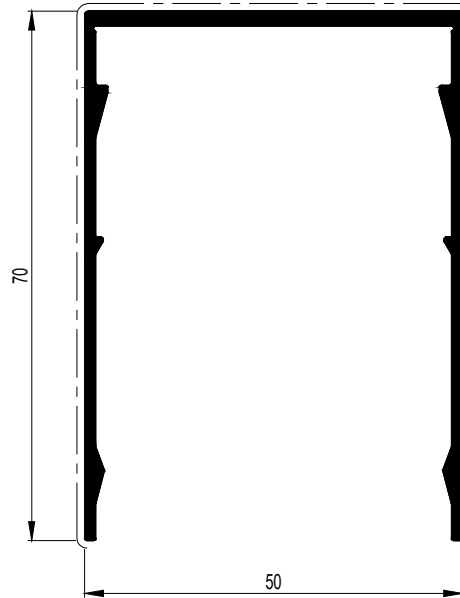

406.0096.00PU

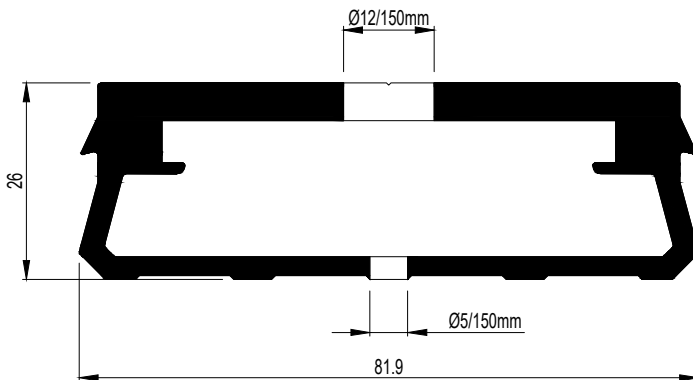

406.0097.XX

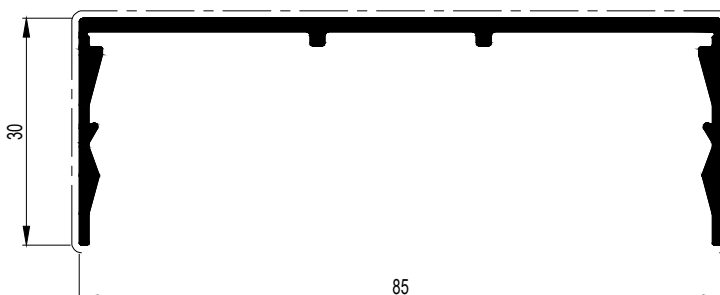

	$\frac{A}{dm^2/m}$	$\frac{P}{dm^2/m}$	$L_m$	$I_x \text{ cm}^4$	$W_x \text{ cm}^3$	ax mm	$I_y \text{ cm}^4$	$W_y \text{ cm}^3$	ay mm	
406.0099.XXPU	19.92	11.5	4.00	12.418	4.433	28.02	3.826	1.604	11.15	
043.1028.XX	9.59	2.3	6.00	-	-	-	-	-	-	
030.1099.XX	22.25	13.6	7.00	21.049	6.145	34.25	5.071	1.930	26.27	

406.0099.XXPU

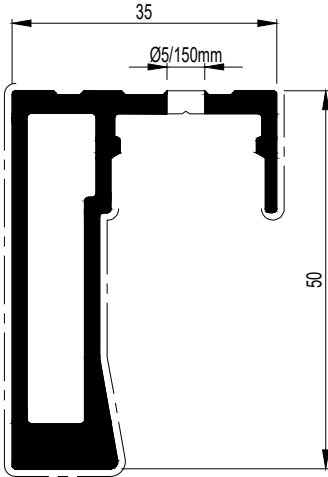

043.1028.XX

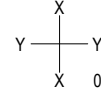
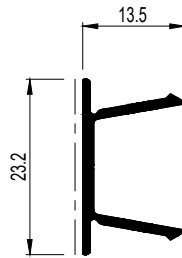

030.1099.XX

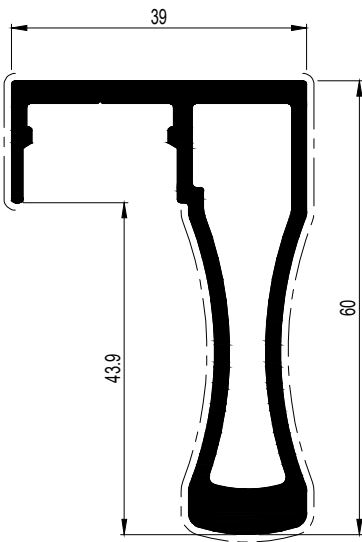

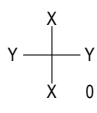
	$\frac{A}{dm^2/m}$	$\frac{P}{dm^2/m}$	$\leftarrow L_m \rightarrow$	$I_x \text{ cm}^4$	$W_x \text{ cm}^3$	ax mm	$I_y \text{ cm}^4$	$W_y \text{ cm}^3$	ay mm	
406.0336.XX	9.72	4.7	7.00	0.120	0.221	5.44	1.079	0.602	17.29	
406.0338.XX	14.73	6.5	7.00	1.113	0.640	8.83	1.817	0.723	11.09	
408.0549.XX	12.18	3.1	7.00	0.288	0.227	5.08	0.950	0.470	11.78	
130.0920.XX	18.56	6.2	7.00	0.411	0.227	4.69	2.075	0.782	26.53	

406.0336.XX

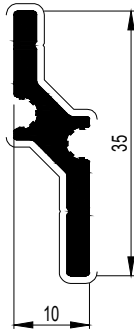

406.0338.XX

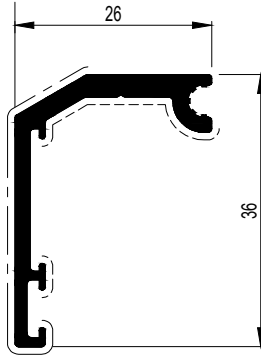

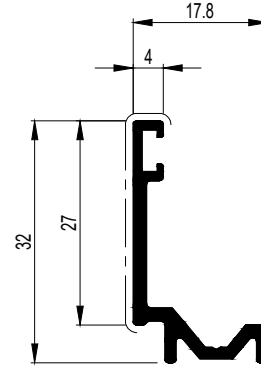

408.0549.XX



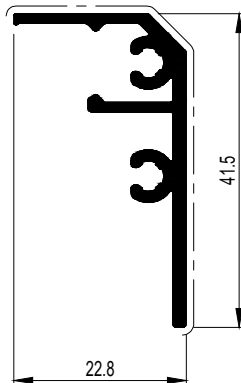







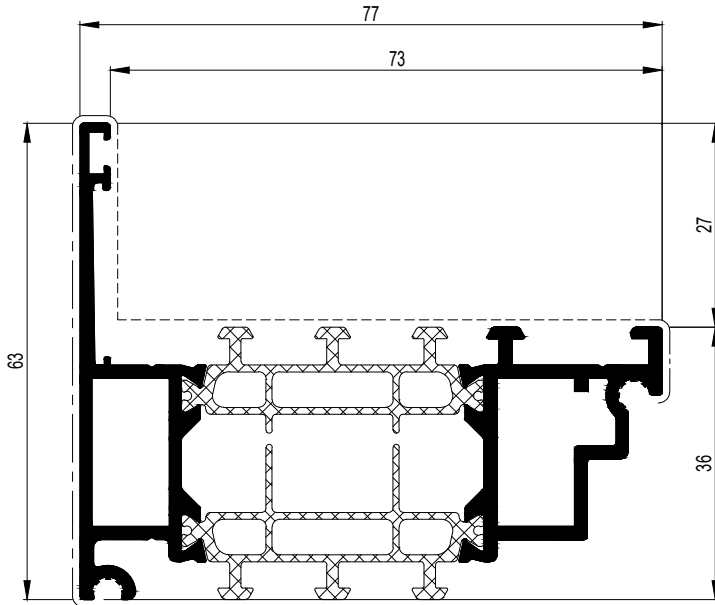







130.0920.XX



	$\frac{A}{dm^2/m}$	$\frac{P}{dm^2/m}$	$L_m$	$I_x \text{ cm}^4$	$W_x \text{ cm}^3$	ax mm	$I_y \text{ cm}^4$	$W_y \text{ cm}^3$	ay mm	
408.4001.XX	32.00	8.0	7.00	21.863	4.892	44.69	8.387	2.116	23.69	
508.4001.XX	32.25	8.0	7.00	21.863	4.892	44.69	8.388	2.116	23.69	

408.4001.XX  
508.4001.XX HI+





 <b>408.4001.XX</b>		 <b>508.4001.XX</b>	
 168.8001.00	095.H800.00	 168.8001.00	095.H800.00
 168.8002.00	095.H800.00	 168.8002.00	095.H800.00
 168.8001.00	095.B500.00	 168.8001.00	095.B500.00
 168.8002.00	095.B500.00	 168.8002.00	095.B500.00
 160.8723.--	---	 160.8723.--	---
 160.8750.--	---	 160.8750.--	---

	$\frac{A}{dm^2/m}$	$\frac{P}{dm^2/m}$	$L_m$	$I_x \text{ cm}^4$	$W_x \text{ cm}^3$	ax mm	$I_y \text{ cm}^4$	$W_y \text{ cm}^3$	ay mm	
408.0164.XX	51.09	19.2	7.00	172.339	18.954	89.28	17.169	4.275	20.05	
508.0164.XX	51.09	19.2	7.00	172.339	18.954	89.28	17.169	4.275	20.05	

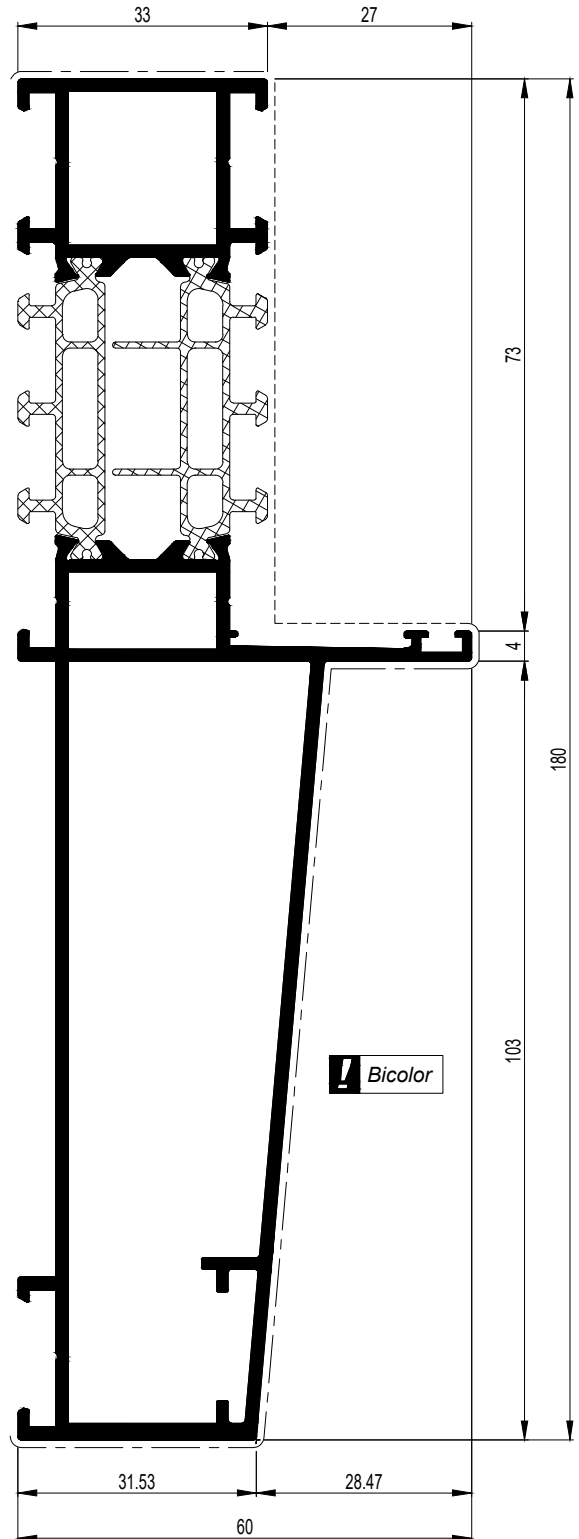
408.0164.XX  
 508.0164.XX HI+





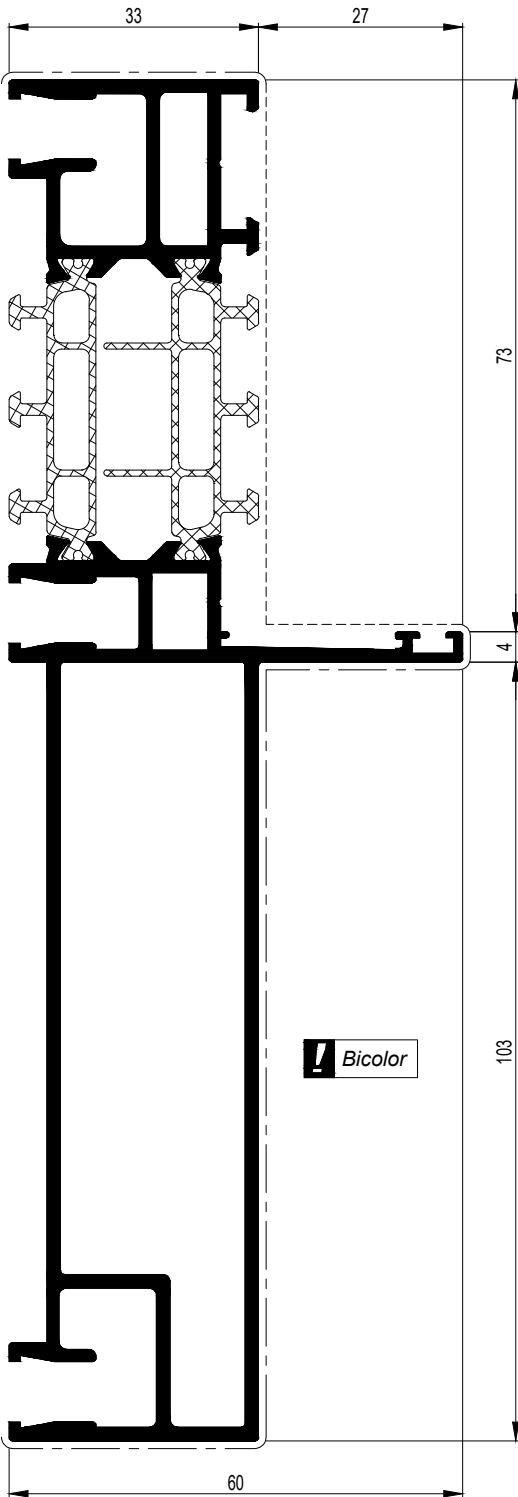

	<b>408.0164.XX</b>		<b>508.0164.XX</b>		
	168.7002.00 (x2) 168.8002.00 168.5000.00 (x2)	095.H800.00		168.7002.00 (x2) 168.8002.00 168.5000.00 (x2)	095.H800.00
	168.7102.00 168.8102.00 168.7002.00 168.5000.00 (x2)	095.H800.00		168.7102.00 168.8102.00 168.7002.00 168.5000.00 (x2)	095.H800.00
	168.7002.00 (x2) 168.8002.00 168.5000.00 (x2)	095.B500.00		168.7002.00 (x2) 168.8002.00 168.5000.00 (x2)	095.B500.00
	168.7102.00 168.8102.00 168.7002.00 168.5000.00 (x2)	095.B500.00		168.7102.00 168.8102.00 168.7002.00 168.5000.00 (x2)	095.B500.00
	168.7002.00 (2x) 168.8002.00 168.5000.00 (4x) 168.5012.--	097.0205.00		168.7002.00 (2x) 168.8002.00 168.5000.00 (4x) 168.5012.--	097.0205.00
	168.8905.00 (2x) 052.5311.-- (4x)	097.0192.00		168.8905.00 (2x) 052.5311.-- (4x)	097.0192.00
	160.8750.--	---		160.8723.--	---
	160.8723.--	---		160.8750.--	---

	$\frac{A}{dm^2/m}$	$\frac{P}{dm^2/m}$	$L_m$	$I_x \text{ cm}^4$	$W_x \text{ cm}^3$	ax mm	$I_y \text{ cm}^4$	$W_y \text{ cm}^3$	ay mm	
408.0884.XX	65.49	20.1	7.00	196.841	21.830	89.83	15.442	3.786	19.22	

408.0884.XX  
 508.0884.XX HI+



	<b>408.0884.XX</b>	
	160.8723.--	---
	160.8750.--	---

			$L_m$	$I_x \text{ cm}^4$	$W_x \text{ cm}^3$	$a_x \text{ mm}$	$I_y \text{ cm}^4$	$W_y \text{ cm}^3$	$a_y \text{ mm}$	
408.3180.XX	55.84	32.6	7.00	209.119	21.483	82.37	25.565	5.863	43.60	
508.3180.XX	55.84	32.6	7.00	209.119	21.483	82.37	25.565	5.863	43.60	

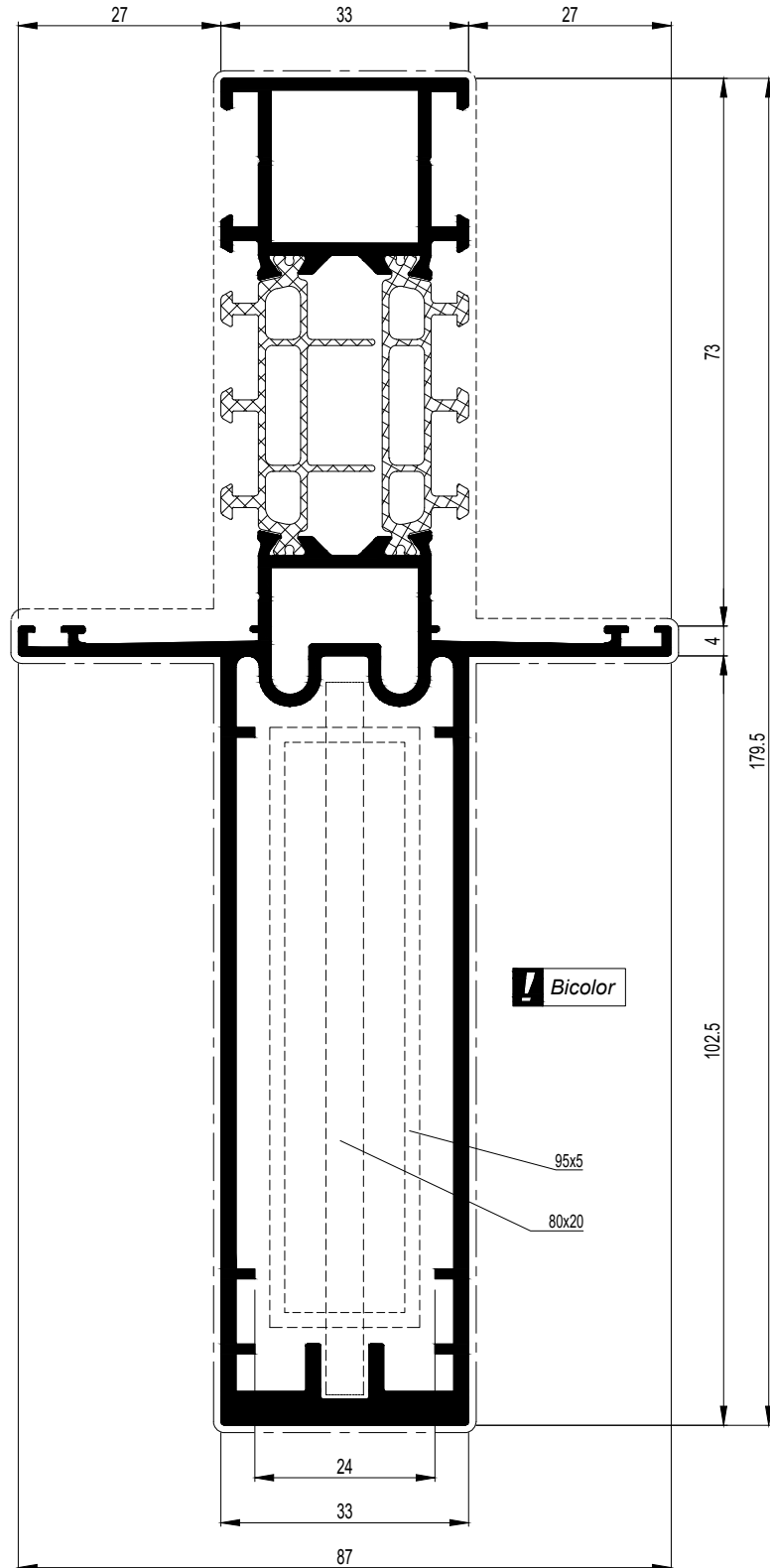

408.3180.XX  
 508.3180.XX HI+



	<b>508.3180.XX</b>	
	<b>408.3180.XX</b>	
	168.7002.00	095.H800.00
	168.8002.00	
	168.7102.00	095.H800.00
	168.8102.00	
	168.7002.00	095.B500.00
	168.8002.00	
	168.7102.00	095.B500.00
	168.8102.00	
	168.7002.00	197.F900.00
	168.8002.00	of-ou-or-oder
	168.5000.00 (2x)	097.0205.00
	168.5012.--	
	168.8688.04 (2x)	
	168.8712.00	197.F900.00
	160.8750.-- (2x)	of-ou-or-oder
	168.8742.00	097.0205.00
	168.5012.--	
	160.8715.--	
	160.8716.--	
	168.8775.00	097.0192.00
	052.5311.--	
	053.5405.-- (2x)	
	160.8715.--	
	160.8716.--	
	168.8905.00	097.0192.00
	052.5311.-- (2x)	
	160.8723.-- (2x)	
	160.8750.-- (2x)	





408.3180.XX + ALU 80x20x2 :  $I_x = 235.922 \text{ cm}^4$   
 408.3180.XX + St/fer 95x5 :  $I_x = 402.296 \text{ cm}^4$

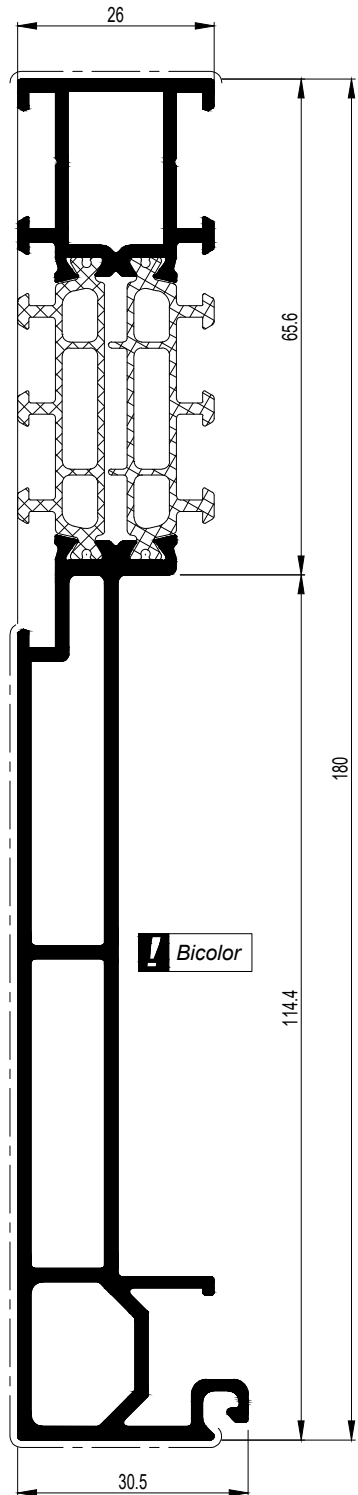
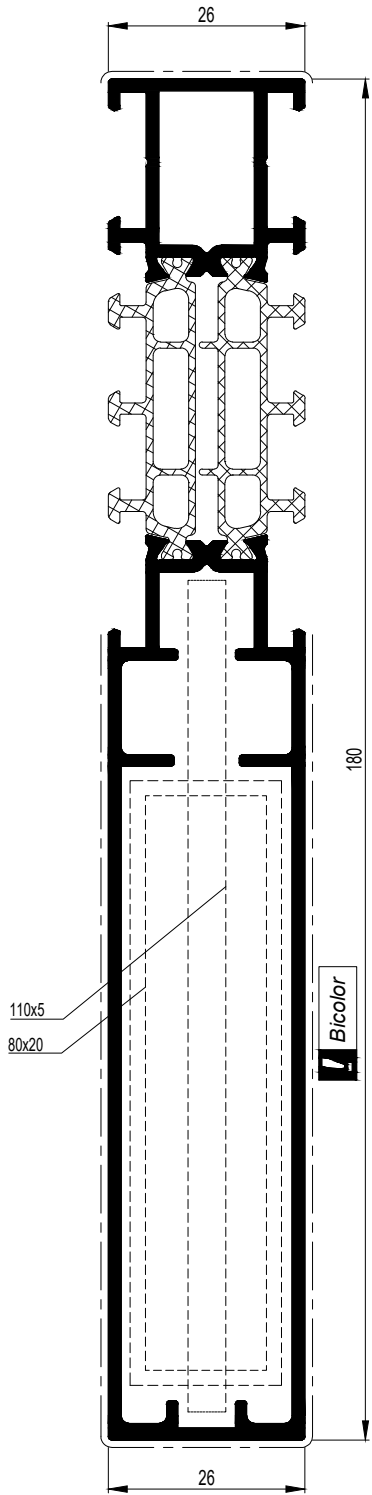

	$\frac{A}{dm^2/m}$	$\frac{P}{dm^2/m}$	$L_m$	$I_x \text{ cm}^4$	$W_x \text{ cm}^3$	ax mm	$I_y \text{ cm}^4$	$W_y \text{ cm}^3$	ay mm	
408.0176.XX	41.29	26.6	7.00	147.373	16.066	88.48	7.332	5.596	13.10	Y X 0 Y
408.0180.XX	47.96	16.2	7.00	165.624	16.867	81.80	4.649	2.288	10.18	

408.0176.XX  
 508.0176.XX HI+

408.0180.XX  
 508.0180.XX HI+



 408.0176.XX + ALU 80x20x2 :  $I_x = 180.623 \text{ cm}^4$   
 408.0176.XX + St/fer 110x5 :  $I_x = 320.194 \text{ cm}^4$

	$\frac{A}{dm^2/m}$	$\frac{P}{dm^2/m}$	$\leftarrow L_m \rightarrow$	$I_x \text{ cm}^4$	$W_x \text{ cm}^3$	ax mm	$I_y \text{ cm}^4$	$W_y \text{ cm}^3$	ay mm	
408.0079.XX	12.88	-	7.00	0.251	0.282	8.91	0.930	0.475	12.64	
408.0081.XX	16.01	3.1	7.00	0.667	0.493	8.28	0.886	0.588	12.14	

## 408.0079.XX

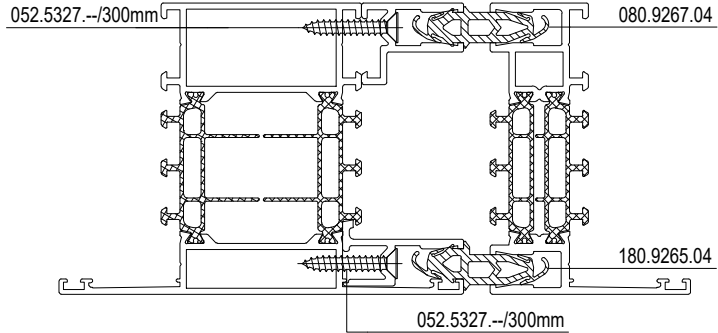
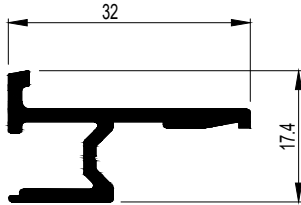

## 408.0081.XX

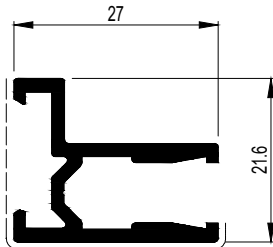

	$\frac{A}{dm^2/m}$	$\frac{P}{dm^2/m}$	$L_m$	$I_x \text{ cm}^4$	$W_x \text{ cm}^3$	ax mm	$I_y \text{ cm}^4$	$W_y \text{ cm}^3$	ay mm	
408.0442.XX	33.98	11.5	7.00	24.899	6.171	40.35	10.131	2.526	40.10	X Y 0
508.0442.XX	33.98	11.5	7.00	24.899	6.171	40.35	10.131	2.526	40.10	

408.0442.XX



508.0442.XX HI+

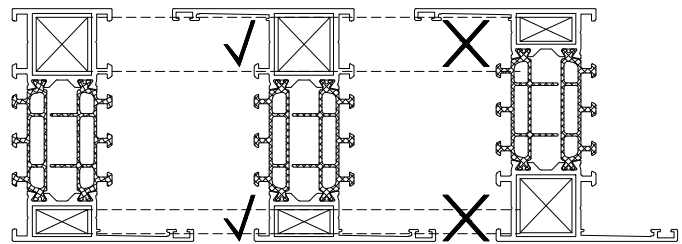
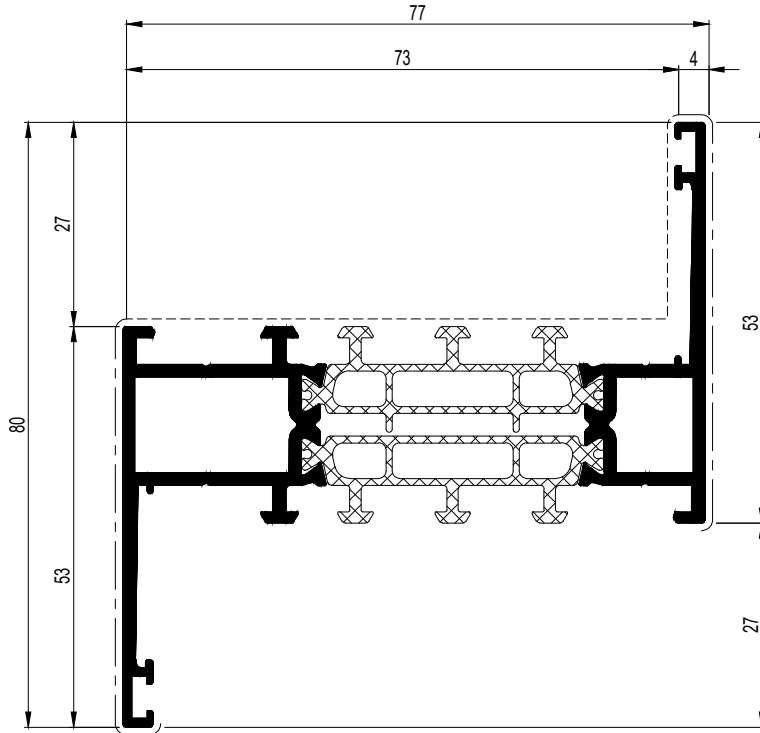

	<b>508.0442.XX</b>	
	<b>408.0442.XX</b>	
	168.7001.00	095.H800.00
	168.8001.00	
	168.7101.00	095.H800.00
	168.8101.00	
	168.7001.00	095.B500.00
	168.8001.00	
	168.7101.00	095.B500.00
	168.8101.00	
	168.7001.00	197.F900.00
	168.8001.00	of-ou-or-oder
	168.5000.00 (2x)	097.0205.00
	168.5012.--	
	168.8688.04 (2x)	
	168.8711.00	197.F900.00
	160.8750.-- (2x)	of-ou-or-oder
	168.8721.00	097.0205.00
	168.5012.--	
	160.8715.-- (2x) or	
	160.8716.-- (2x)	
	168.8770.00	097.0192.00
	053.5405.-- (2x)	
	160.8715.-- (2x) or	
	160.8716.-- (2x)	
	168.8900.00	097.0192.00
	160.8723.-- (2x)	
	160.8750.-- (2x)	

	$\frac{A}{dm^2/m}$	$\frac{P}{dm^2/m}$	$L_m$	$I_x \text{ cm}^4$	$W_x \text{ cm}^3$	ax mm	$I_y \text{ cm}^4$	$W_y \text{ cm}^3$	ay mm	
408.0443.XX	35.38	12.9	7.00	27.682	6.951	39.82	14.154	3.246	43.60	
508.0443.XX	35.38	12.9	7.00	27.682	6.951	39.82	14.154	3.246	43.60	

408.0443.XX  
508.0443.XX HI+

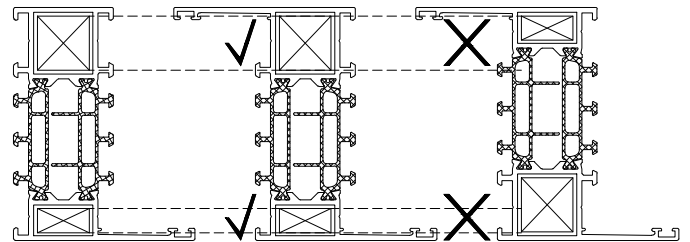
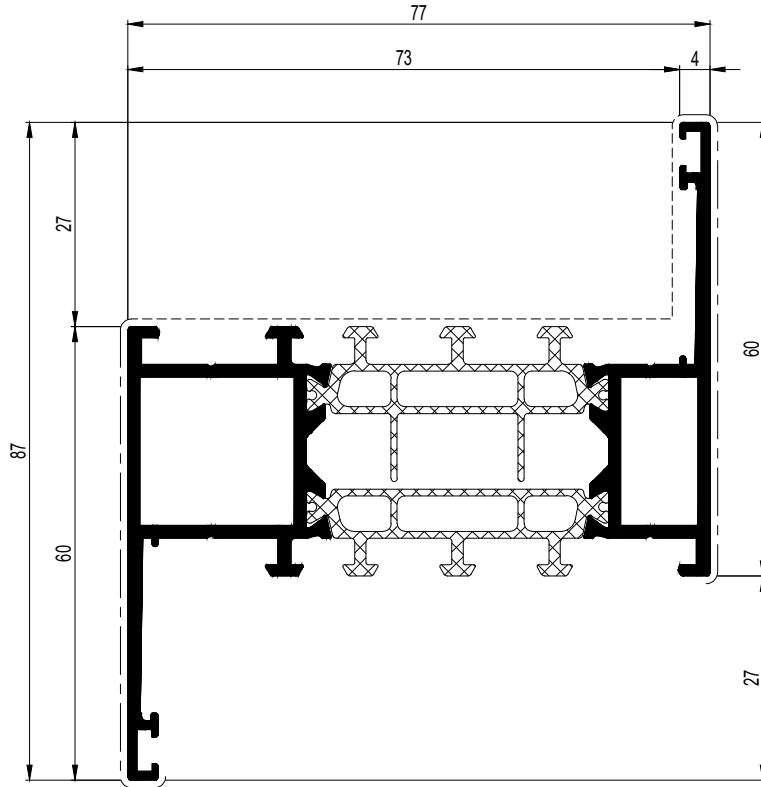

	<b>508.0443.XX</b>	
	<b>408.0443.XX</b>	
	168.7002.00	095.H800.00
	168.8002.00	
	168.7102.00	095.H800.00
	168.8102.00	
	168.7002.00	095.B500.00
	168.8002.00	
	168.7102.00	095.B500.00
	168.8102.00	
	168.7002.00	197.F900.00
	168.8002.00	of-ou-or-oder
	168.5000.00 (2x)	097.0205.00
	168.5012.--	
	168.8688.04 (2x)	
	168.8712.00	197.F900.00
	160.8750.-- (2x)	of-ou-or-oder
	168.8742.00	097.0205.00
	168.5012.--	
	160.8715.-- (2x) or	
	160.8716.-- (2x)	
	168.8775.00	097.0192.00
	052.5311.--	
	053.5405.-- (2x)	
	160.8715.-- (2x) or	
	160.8716.-- (2x)	
	168.8905.00	097.0192.00
	052.5311.-- (2x)	
	160.8723.-- (2x)	
	160.8750.-- (2x)	

	$\frac{A}{dm^2/m}$	$\frac{P}{dm^2/m}$	$L_m$	$I_x \text{ cm}^4$	$W_x \text{ cm}^3$	ax mm	$I_y \text{ cm}^4$	$W_y \text{ cm}^3$	ay mm	
408.0444.XX	39.38	17.3	7.00	34.939	8.953	39.03	32.465	6.057	53.60	X Y 0
508.0444.XX	39.38	17.3	7.00	34.939	8.953	39.03	32.465	6.057	53.60	

408.0444.XX



508.0444.XX HI+

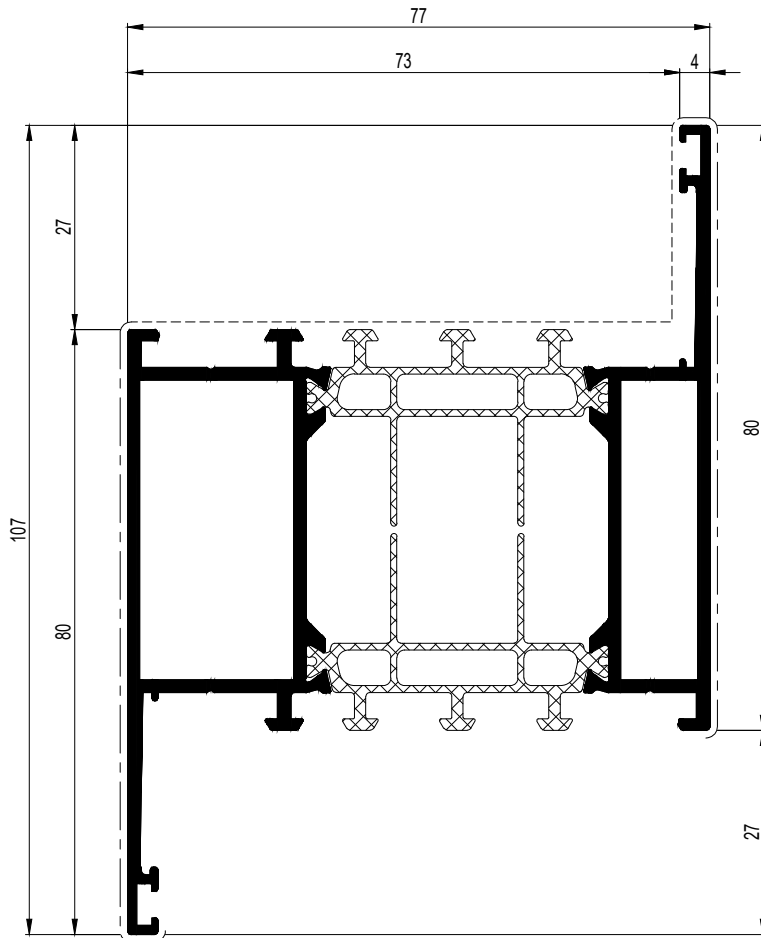

	<b>508.0444.XX</b>	
	<b>408.0444.XX</b>	
	168.7004.00 168.8004.00	095.H800.00
	168.7104.00 168.8104.00	095.H800.00
	168.7004.00 168.8004.00	095.B500.00
	168.7104.00 168.8104.00	095.B500.00
	168.7004.00 168.8004.00 168.5000.00 (2x) 168.5012.--	197.F900.00 of-ou-or-oder 097.0205.00
	168.8688.04 (2x)	
	168.8714.00 160.8750.-- (2x) 168.8742.00 (2x) 168.5012.--	197.F900.00 of-ou-or-oder 097.0205.00
	160.8715.-- (2x) or 160.8716.-- (2x)	
	168.8775.00 168.8910.04 (2x) 052.5311.-- 053.5405.-- (2x)	097.0192.00
	160.8715.-- (2x) or 160.8716.-- (2x)	
	168.8905.00 168.8910.04 (4x) 052.5311.-- (2x)	097.0192.00
	160.8723.-- (2x)	
	160.8750.-- (2x)	

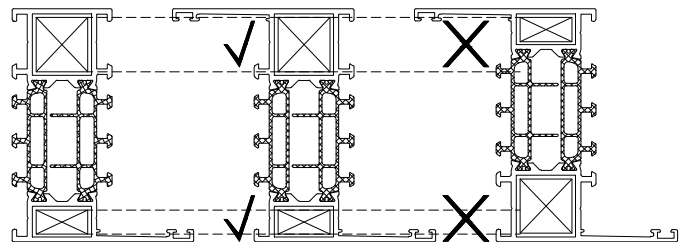

	$\frac{A}{dm^2/m}$	$\frac{P}{dm^2/m}$	$L_m$	$I_x \text{ cm}^4$	$W_x \text{ cm}^3$	ax mm	$I_y \text{ cm}^4$	$W_y \text{ cm}^3$	ay mm	
004.3130.XX	19.05	1.6	6.00	1.141	0.774	27.84	1.881	0.675	11.18	
004.3843.XX	24.19	8.1	6.00	3.916	1.248	15.63	1.609	0.940	17.13	
130.1143.XX	22.82	7.9	6.00	3.500	1.059	15.66	2.249	1.053	15.33	

## 004.3130.XX

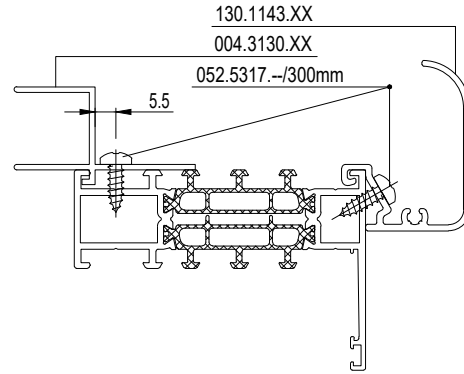
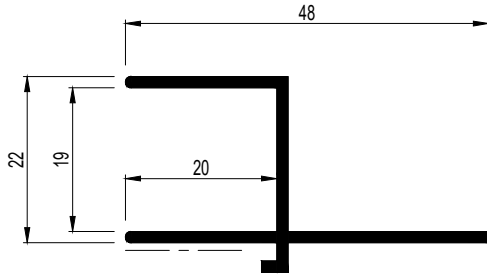

## 004.3843.XX

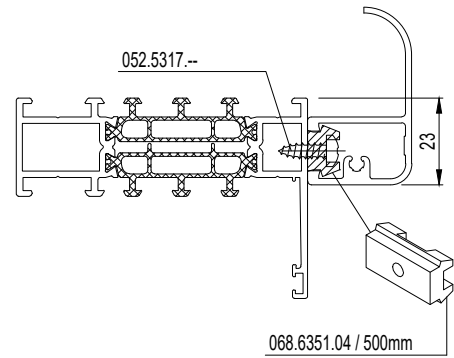
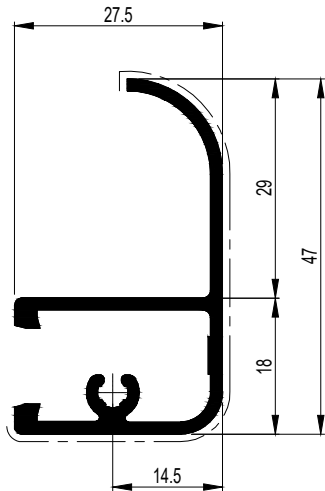

## 130.1143.XX

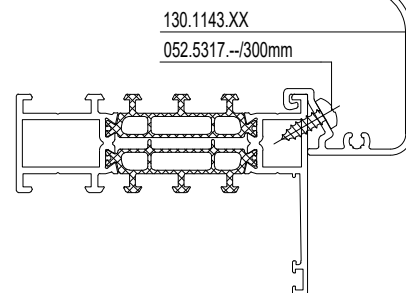
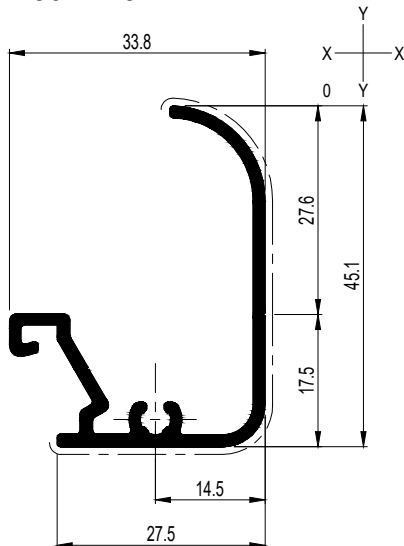

	$\frac{A}{dm^2/m}$	$\frac{P}{dm^2/m}$	$L_m$	$I_x \text{ cm}^4$	$W_x \text{ cm}^3$	ax mm	$I_y \text{ cm}^4$	$W_y \text{ cm}^3$	ay mm	
004.3167.XX	35.96	12.9	6.00	9.873	3.238	28.51	3.238	2.151	12.95	
004.3168.XX	54.76	30.3	6.00	41.102	8.444	47.32	5.965	3.932	12.83	
130.1142.XX	34.76	6.6	6.00	2.982	1.855	13.73	13.084	3.817	31.48	

004.3167.XX

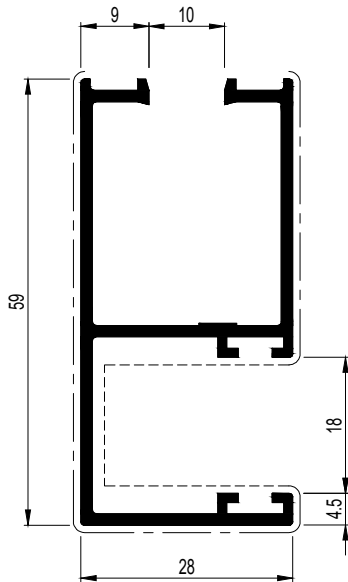

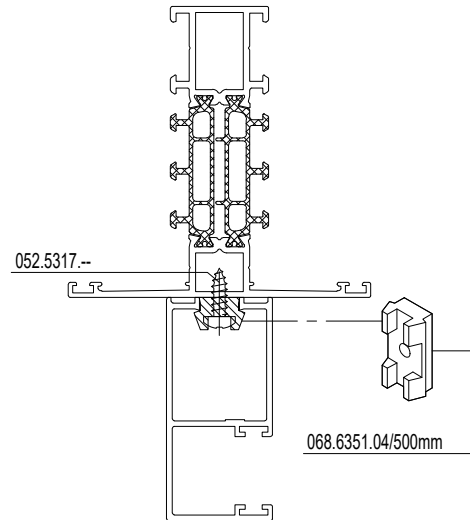
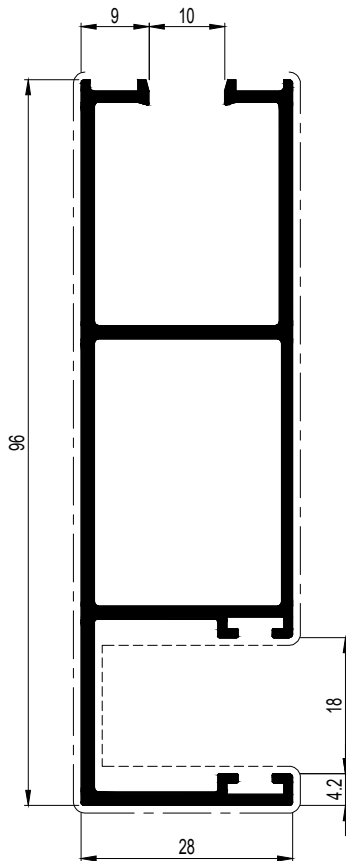

004.3168.XX

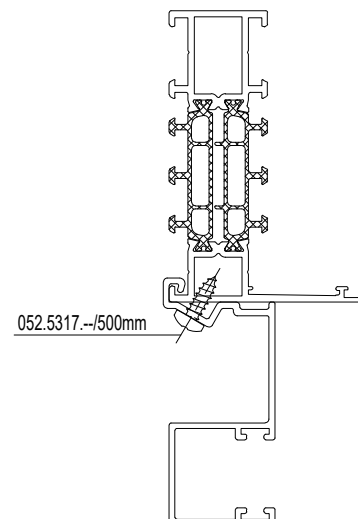
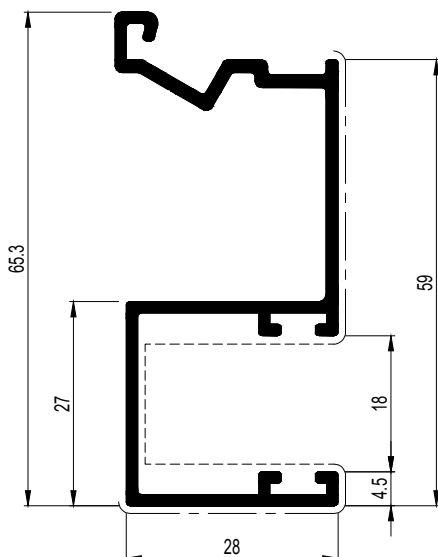

	081.9091.04	
	081.9092.04	
081.9092.04	081.9092.04	10mm
081.9092.04	081.9091.04	12mm
081.9091.04	081.9091.04	14mm
081.9091.04	-	16mm

130.1142.XX

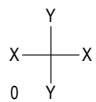

	$\frac{A}{dm^2/m}$	$\frac{P}{dm^2/m}$	$L_m$	$I_x \text{ cm}^4$	$W_x \text{ cm}^3$	ax mm	$I_y \text{ cm}^4$	$W_y \text{ cm}^3$	ay mm	
130.1147.XX	30.22	11.5	6.00	4.375	1.199	12.20	15.694	3.686	31.14	

130.1147.XX

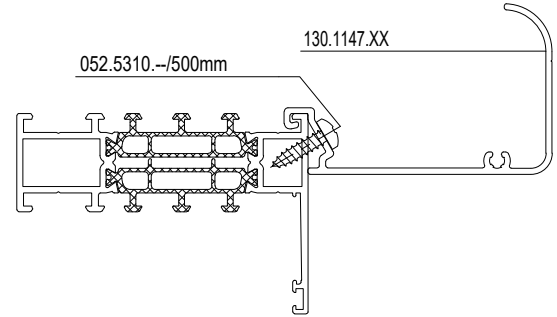
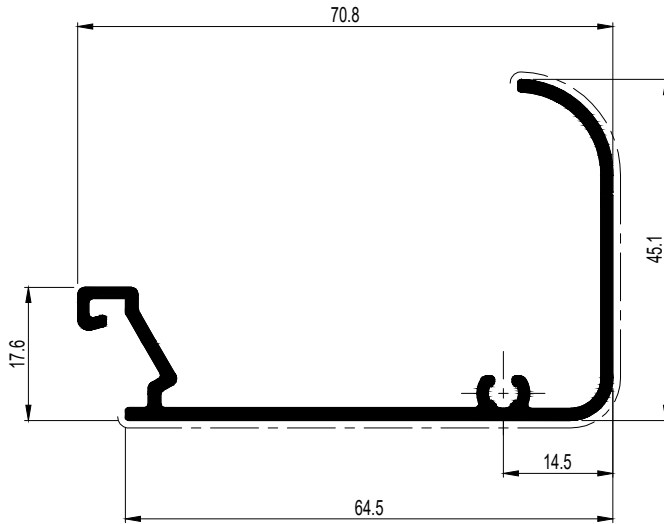

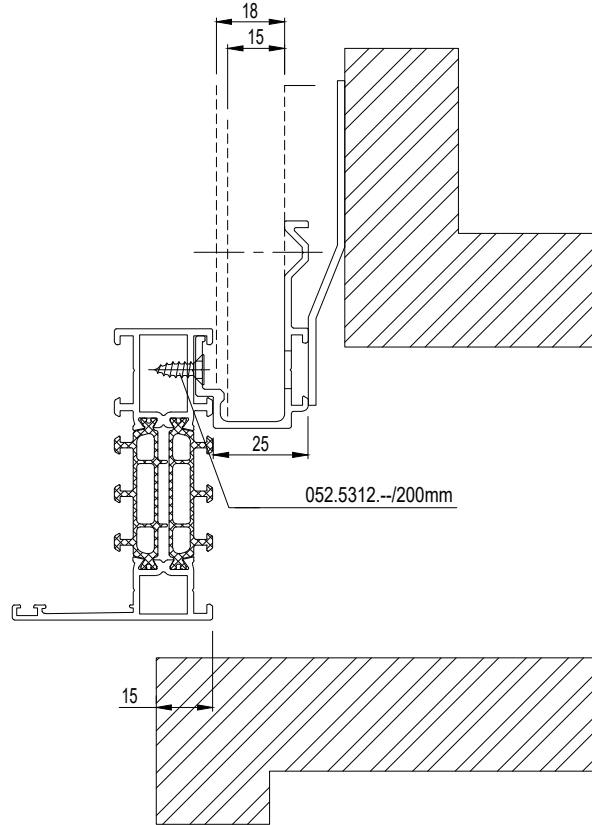
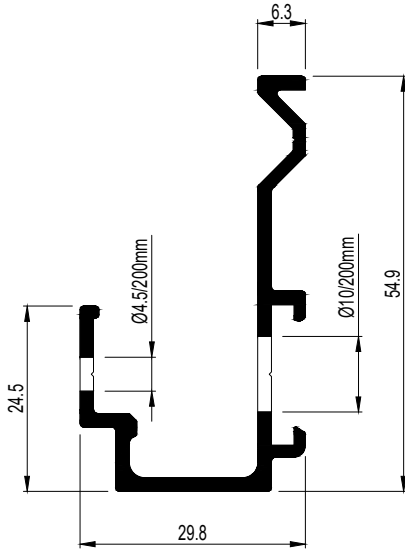

			$L_m$	$I_x \text{ cm}^4$	$W_x \text{ cm}^3$	$a_x \text{ mm}$	$I_y \text{ cm}^4$	$W_y \text{ cm}^3$	$a_y \text{ mm}$	
030.2140.00	-	-	7.00	6.246	1.780	19.80	2.235	1.219	18.34	
030.2141.00	-	-	7.00	5.613	1.672	21.03	1.162	0.793	14.65	

030.2140.00

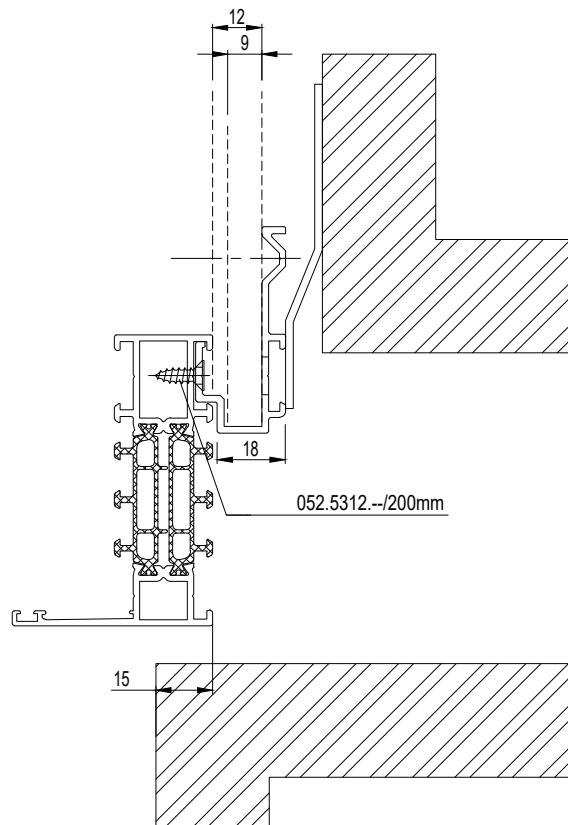
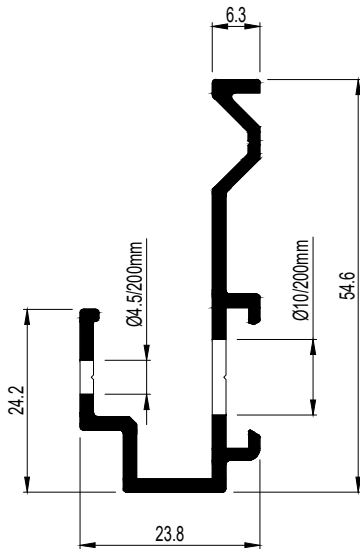

030.2141.00



	$\frac{A}{dm^2/m}$	$\frac{P}{dm^2/m}$	$L_m$	$I_x \text{ cm}^4$	$W_x \text{ cm}^3$	$a_x \text{ mm}$	$I_y \text{ cm}^4$	$W_y \text{ cm}^3$	$a_y \text{ mm}$	
406.0580.07	0.01	-	4.00	917.120	114.672	78.52	31.490	20.429	15.42	

406.0580.07

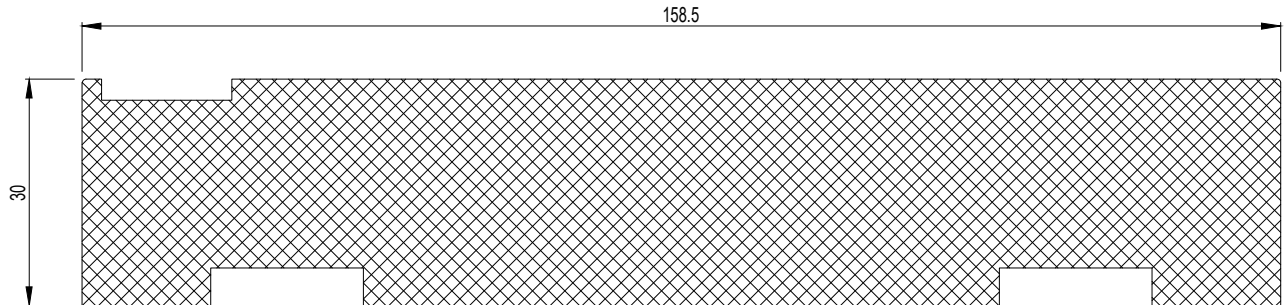

C

	$\frac{A}{dm^2/m}$	$\frac{P}{dm^2/m}$	$L_m$	$I_x \text{ cm}^4$	$W_x \text{ cm}^3$	ax mm	$I_y \text{ cm}^4$	$W_y \text{ cm}^3$	ay mm	
106.0087.17	55.42	0.1	7.00	44.100	10.622	38.48	8.767	2.476	18.29	
106.0093.XX	24.58	0.1	7.00	7.366	2.314	31.83	3.486	1.016	20.48	
106.0089.17	63.02	-	7.00	53.391	11.509	33.61	37.895	5.953	28.05	
106.0090.XX	25.66	5.3	7.00	7.337	2.280	32.17	3.645	1.314	27.74	
034.0420.XX	13.85	6.5	7.00	0.152	0.317	4.80	1.094	0.626	17.47	

106.0087.17

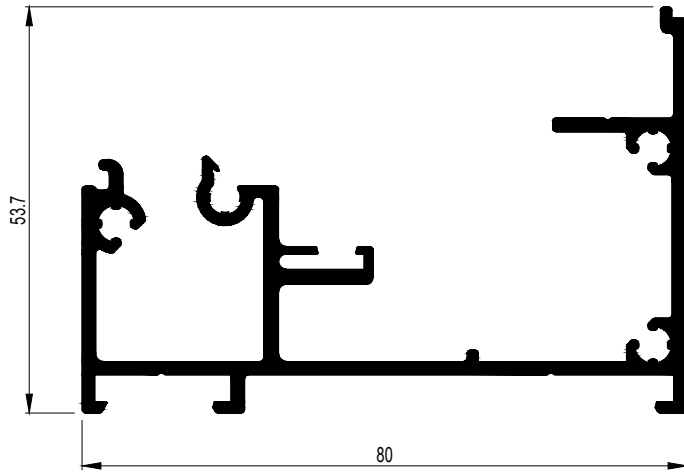

106.0093.XX

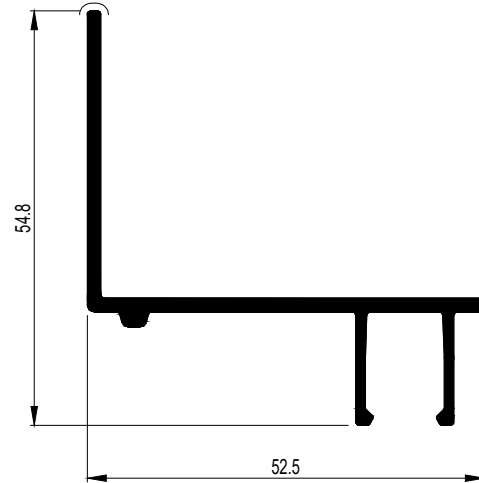

106.0089.17

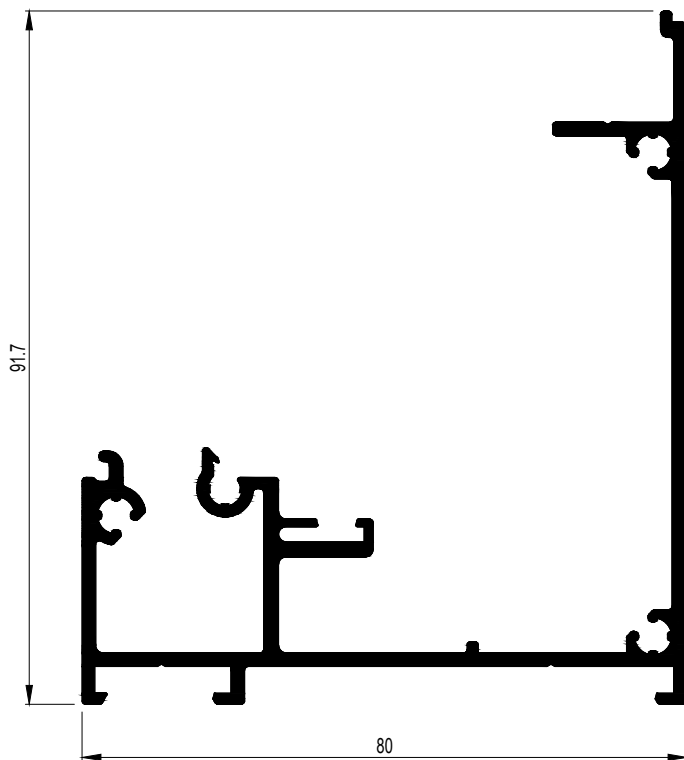

106.0090.XX

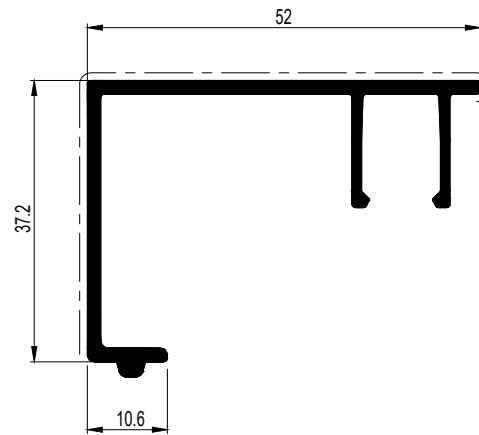

034.0420.XX

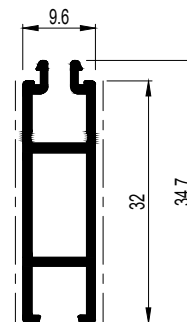

**E**

**R**

Reynaers  
Aluminium

**Werktekeningen**  
**Coupes et débits**  
**Work drawings**  
**Werkzeichnungen**





MONORAIL BUITENBEGLAZING  
 MONORAIL INVERSION PARCLOSE

MONORAIL OUTSIDE GLAZED  
 MONORAIL AUSSENVERGLASUNG

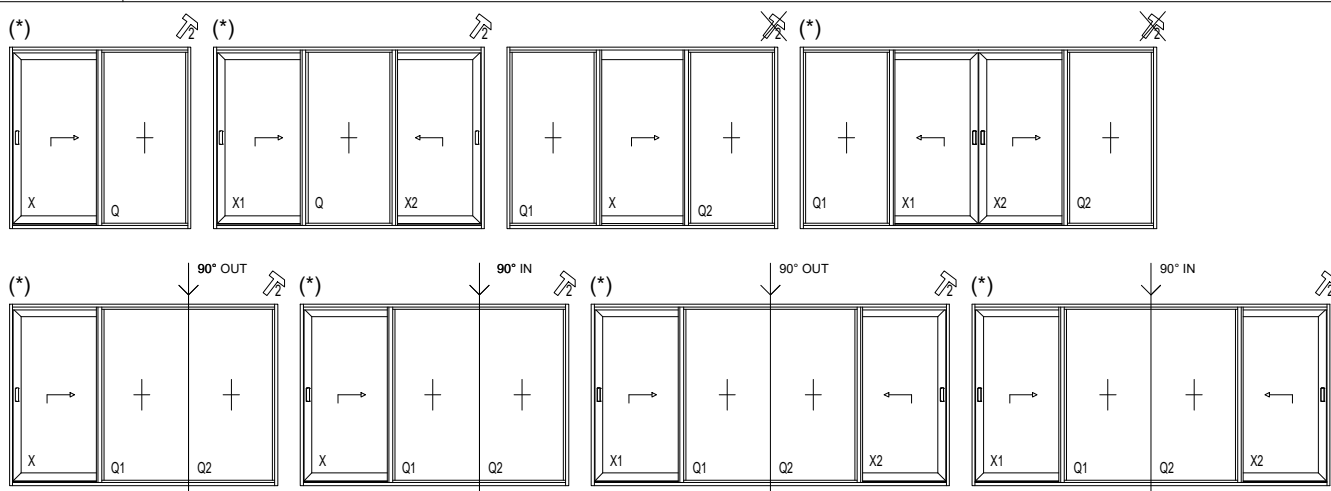

MONORAIL BINNENBEGLAZING  
 MONORAIL INTERIEUR PARCLOSE

MONORAIL INSIDE GLAZED  
 MONORAIL INNENVERGLASUNG

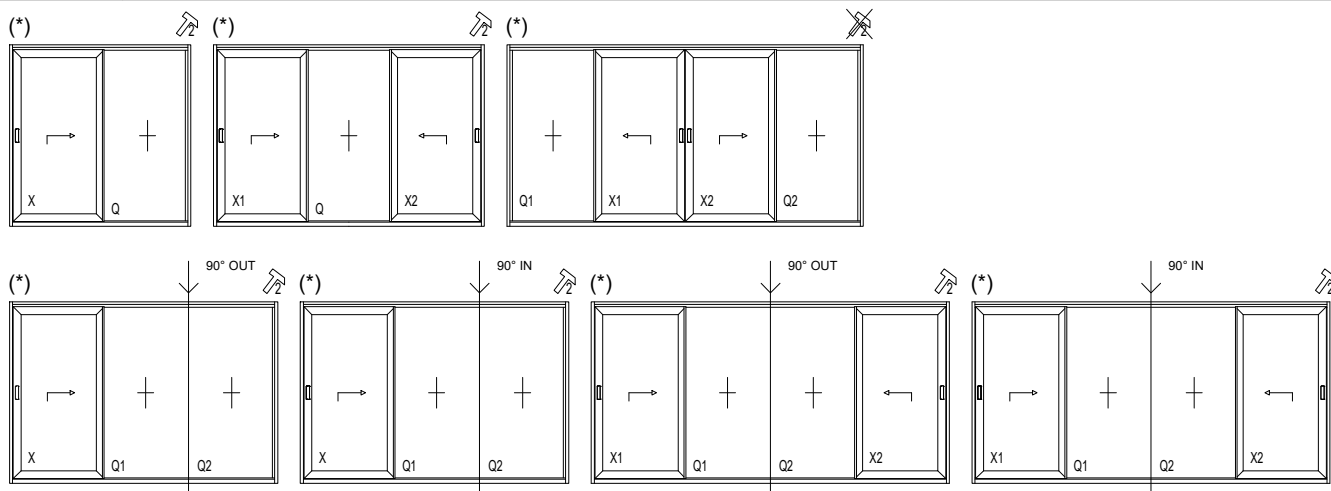

2-RAIL  
 2-RAIL

2-RAIL  
 2-RAIL

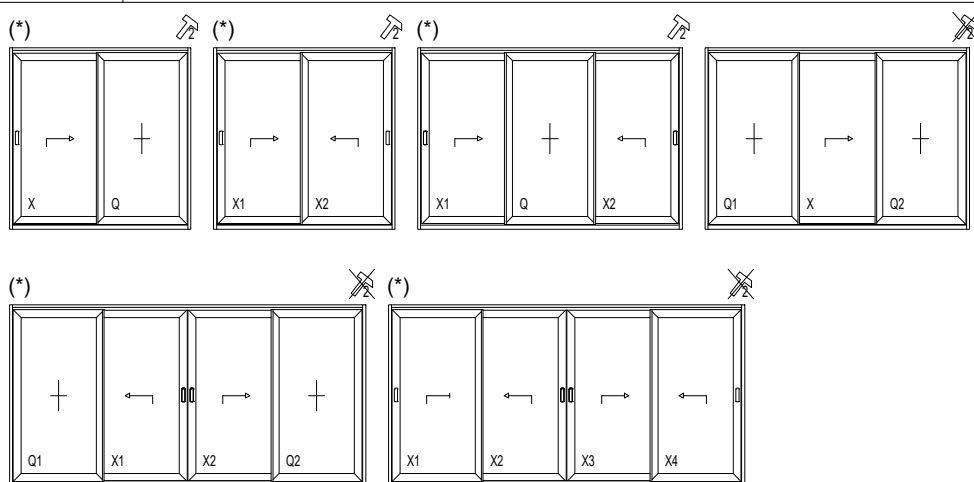

X : PRIMAIRE VLEUGEL  
 Q : VASTE VLEUGEL  
 O : SECUNDAIRE VLEUGEL  
 V : HOEKOPLOSSING

X : OUVRANT PRIMAIRE  
 Q : OUVRANT FIXE  
 O : OUVRANT SECUNDAIRE  
 V : SOLUTION ANGULAIRE

X : PRIMARY SLIDING VENT  
 Q : FIXED VENT  
 O : SECONDARY SLIDING VENT  
 V : CORNER SOLUTION

X : GANGFLUEGEL  
 Q : FENSTER FLUEGEL  
 O : STANDFLUEGEL  
 V : ECKLÖSUNG

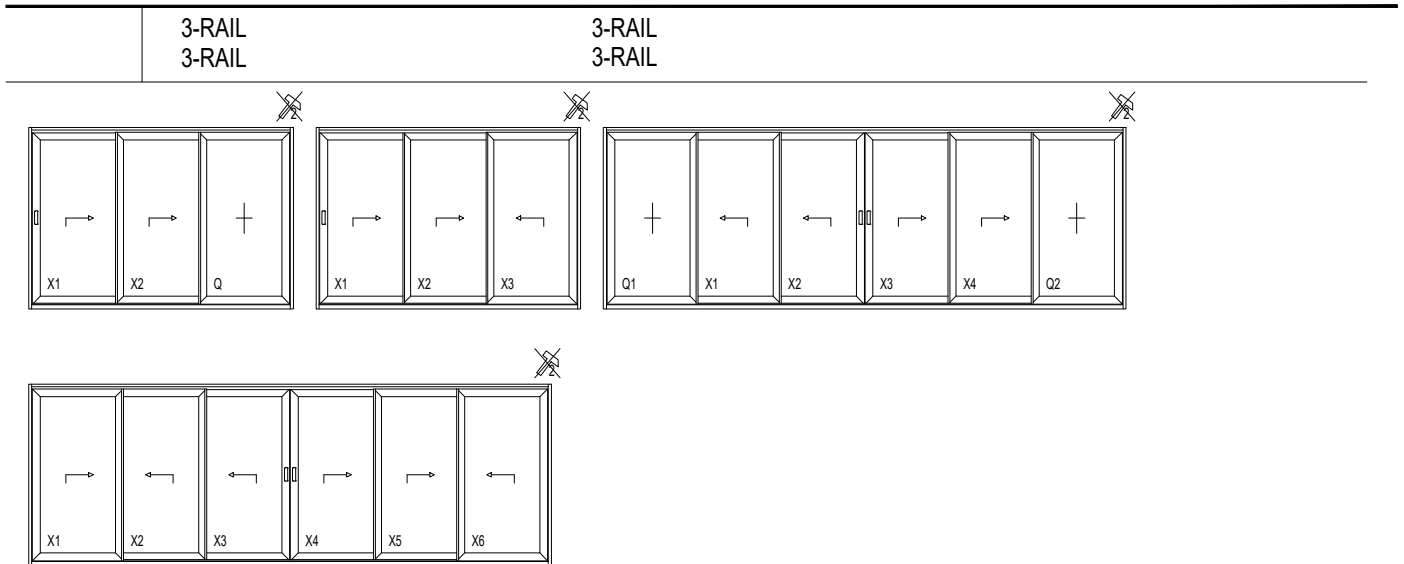

## Explanation naming sections:

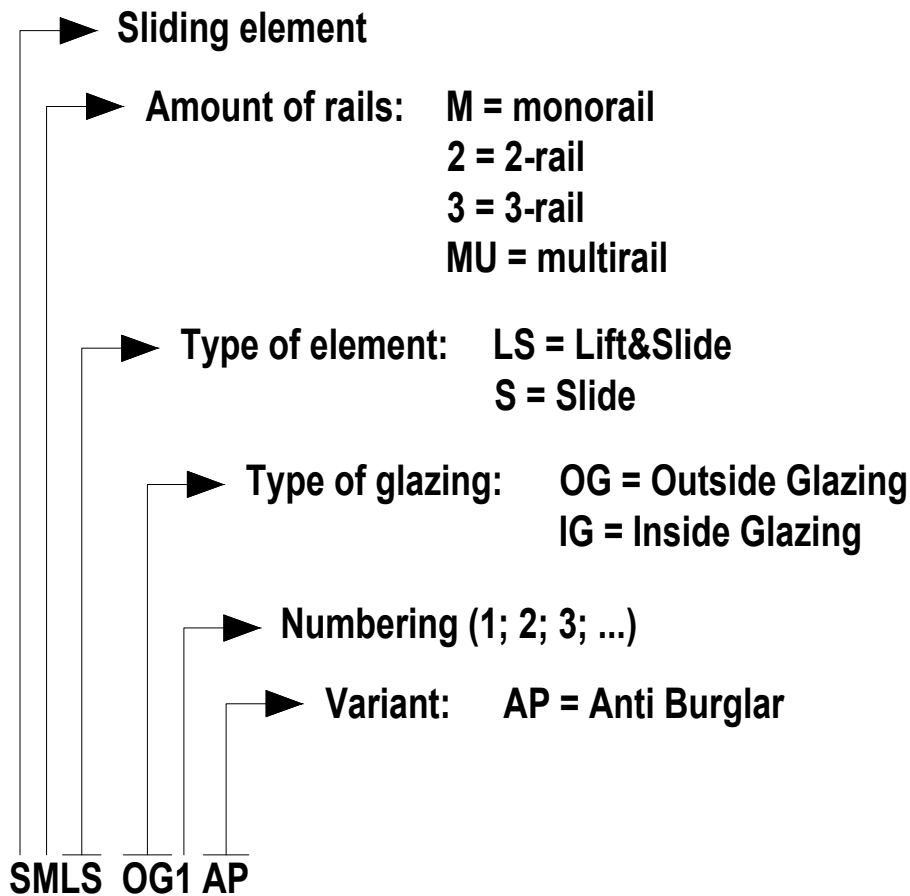

(\*)

SMALLE CHICANE MOGELIJK (406.0330.XX) (OOK AP)  
 CHICANE ETROITE POSSIBLE (406.0330.XX) (AUSSI AP)  
 SLIM CHICANE POSSIBLE (406.0330.XX) (ALSO AP)  
 SCHMALE SCHIKANE MÖGLICH (406.0330.XX) (EBENFALLS AP)

MONORAIL BUITENBEGLAZING  
 MONORAIL INVERSION PARCLOSE

MONORAIL OUTSIDE GLAZED  
 MONORAIL AUSSENVERGLASUNG

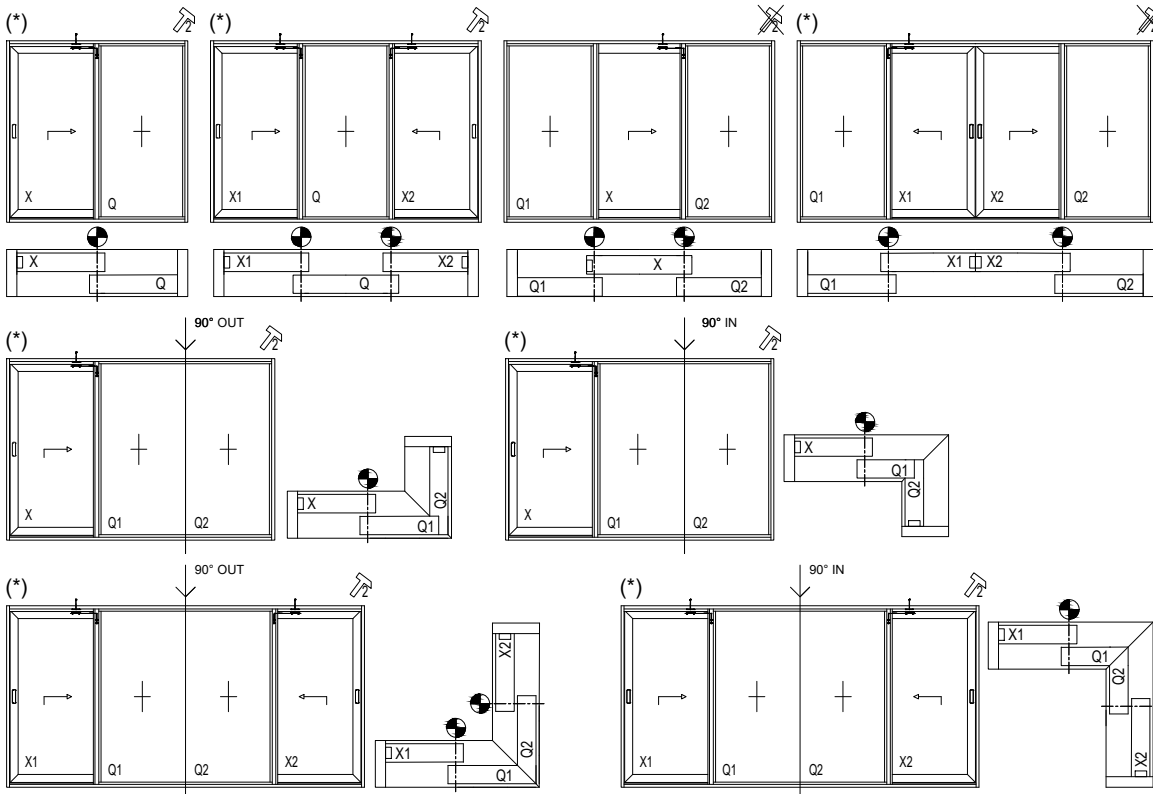

MONORAIL BINNENBEGLAZING  
 MONORAIL INTERIEUR PARCLOSE

MONORAIL INSIDE GLAZED  
 MONORAIL INNENVERGLASUNG

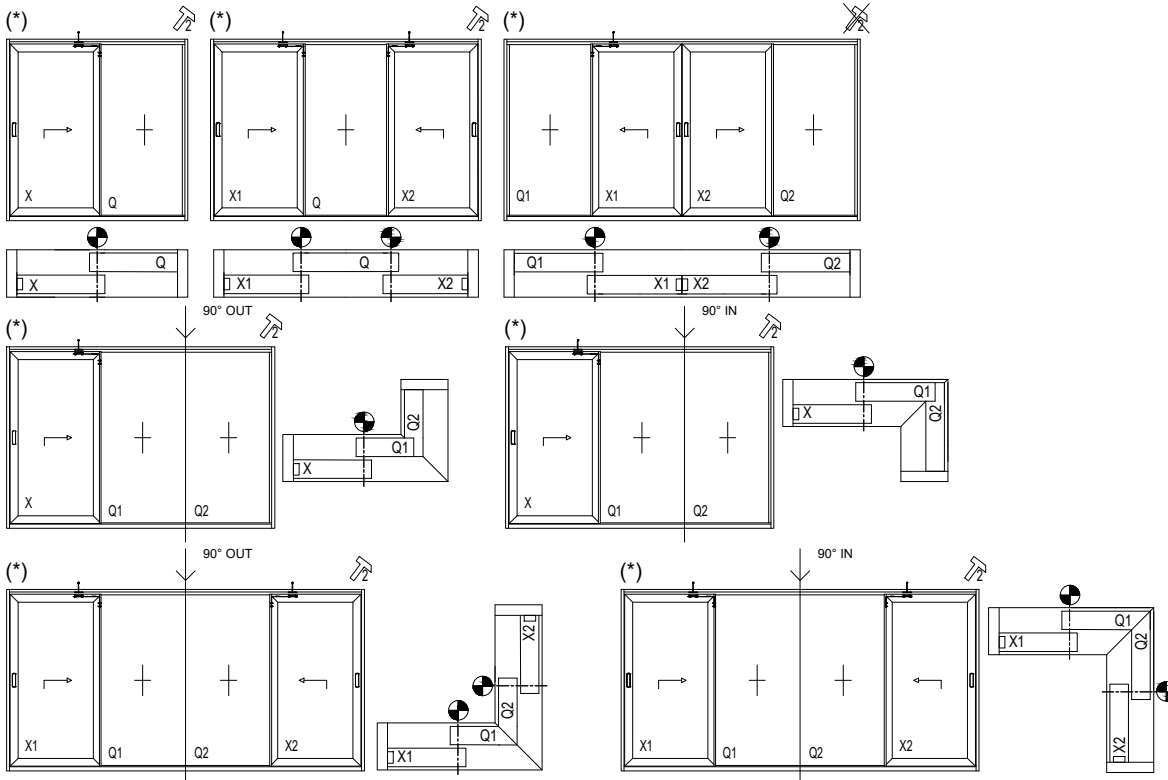

X : PRIMAIRE VLEUGEL  
 Q : VASTE VLEUGEL  
 O : SECUNDAIRE VLEUGEL  
 V : HOEKOPLOSSING

X : OUVRANT PRIMAIRE  
 Q : OUVRANT FIXE  
 O : OUVRANT SECONDAIRE  
 V : SOLUTION ANGULAIRE

X : PRIMARY SLIDING VENT  
 Q : FIXED VENT  
 O : SECONDARY SLIDING VENT  
 V : CORNER SOLUTION

X : GANGFLUEGEL  
 Q : FENSTER FLUEGEL  
 O : STANDFLUEGEL  
 V : ECKLÖSUNG

2-RAIL  
2-RAIL

2-RAIL  
2-RAIL

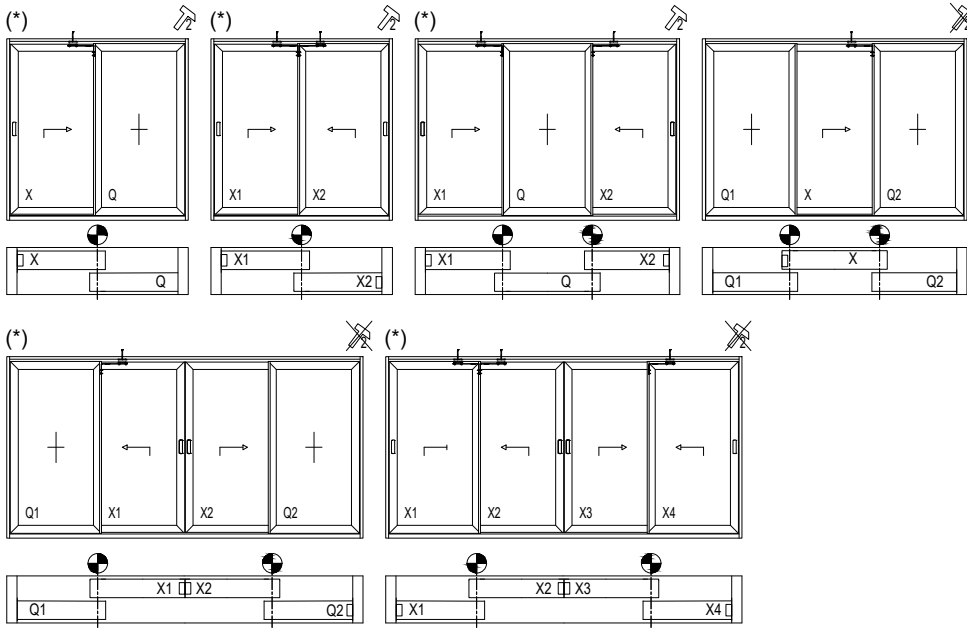

3-RAIL  
3-RAIL

3-RAIL  
3-RAIL

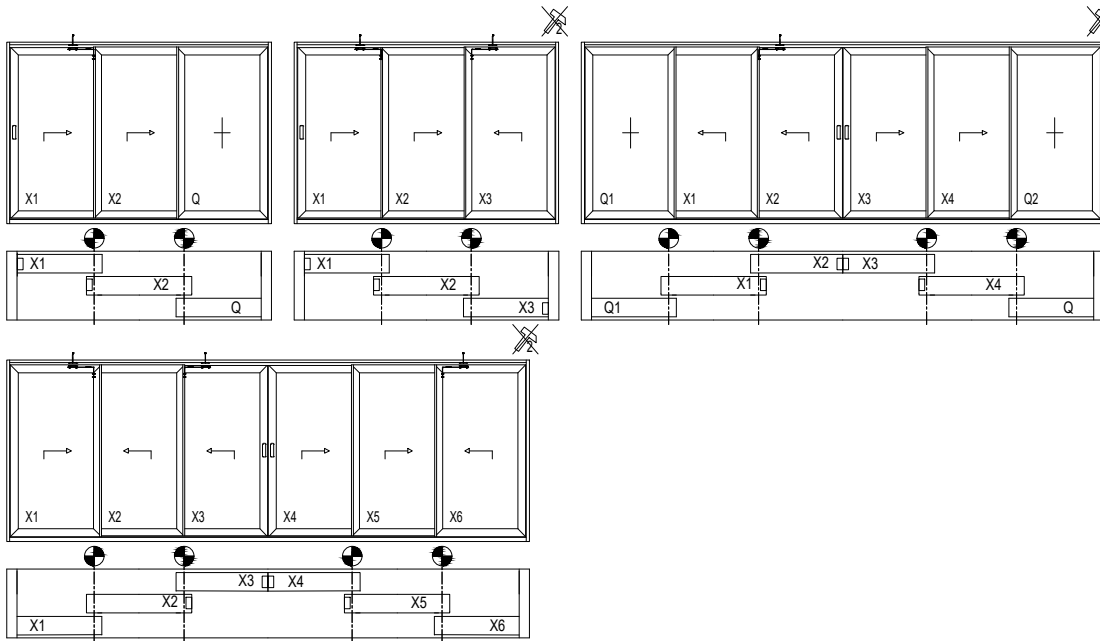

**!** MAGNETISCH CONTACT - INSTALLATIE ENKEL OP PRIMAIRE VLEUGEL  
 CONTACT MAGNÉTIQUE - INSTALLATION UNIQUEMENT SUR VANTAIL PRIMAIRE  
 MAGNETIC CONTACT - INSTALLATION ONLY ON PRIMARY VENT  
 MAGNETKONTAKT - INSTALLATION NUR AUF DAS PRIMÄRFLÜGEL

(\*) SMALLE CHICANE MOGELIJK (406.0330.XX) (OOK AP)  
 CHICANE ETROITE POSSIBLE (406.0330.XX) (AUSSI AP)  
 SLIM CHICANE POSSIBLE (406.0330.XX) (ALSO AP)  
 SCHMALE SCHIKANE MÖGLICH (406.0330.XX) (EBENFALLS AP)

084.9439.07 ISOLEREND VULSTUK NIET MOGELIJK IN COMBINATIE MET 060.6750.04  
 084.9439.07 PIECE DE REMPLISSAGE ISOLEE PAS POSSIBLE EN COMBINAISON AVEC 060.6750.04  
 084.9439.07 INSULATING FILLING PIECE NOT POSSIBLE IN COMBINATION WITH 060.6750.04  
 084.9439.07 ISOLIERENDES FUELLSTUECK NICHT MÖGLICH IN KOMBINATION MIT 060.6750.04

MONORAIL BUITENBEGLAZING  
 MONORAIL INVERSION PARCLOSE

MONORAIL OUTSIDE GLAZED  
 MONORAIL AUSSENVERGLASUNG

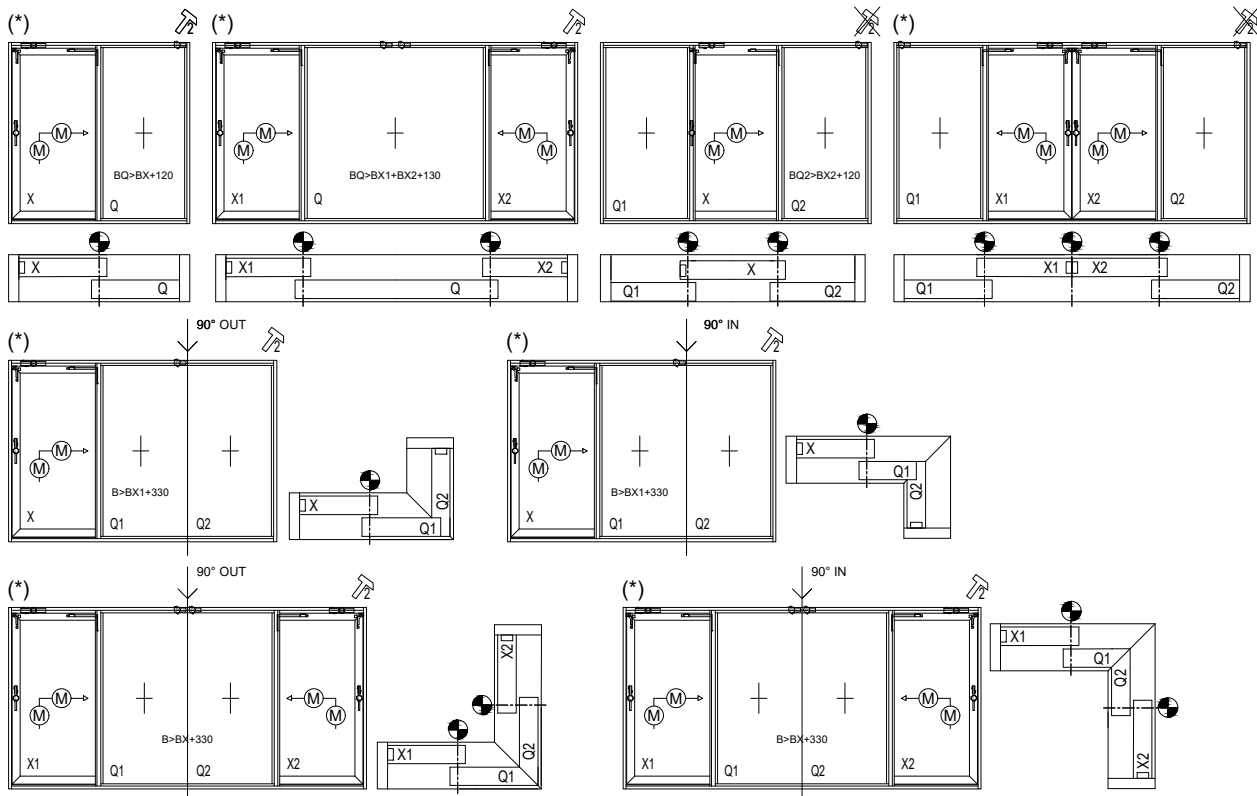

MONORAIL BINNENBEGLAZING  
 MONORAIL INTERIEUR PARCLOSE

MONORAIL INSIDE GLAZED  
 MONORAIL INNENVERGLASUNG

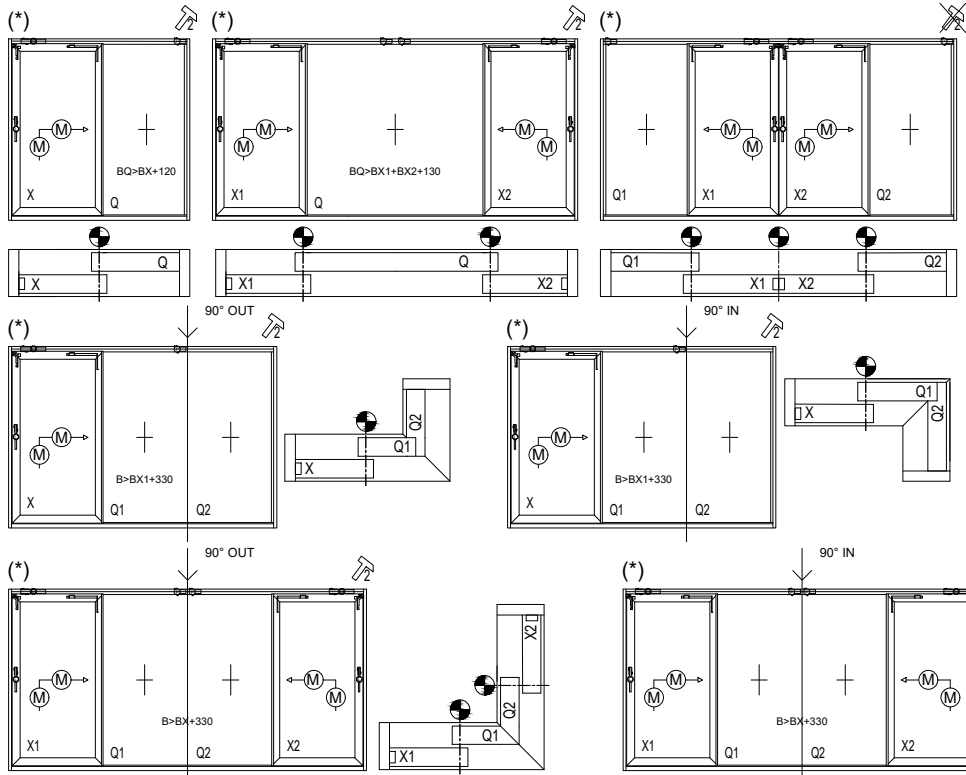

**!**  
 EN 1027  
 EN 12208  
 METHODE B - AFGESCHERMD  
 METHODE B - AVEC PROTECTION  
 METHOD B - SHIELDED  
 METHODE B - GESCHÜTZT

X : PRIMAIRE VLEUGEL  
 Q : VASTE VLEUGEL  
 O : SECUNDAIRE VLEUGEL  
 V : HOEKOPLOSSING

X : OUVRANT PRIMAIRE  
 Q : OUVRANT FIXE  
 O : OUVRANT SECUNDAIRE  
 V : SOLUTION ANGULAIRE

X : PRIMARY SLIDING VENT  
 Q : FIXED VENT  
 O : SECONDARY SLIDING VENT  
 V : CORNER SOLUTION

X : GANGFLUEGEL  
 Q : FENSTER FLUEGEL  
 O : STANDFLUEGEL  
 V : ECKLÖSUNG

2-RAIL  
2-RAIL

2-RAIL  
2-RAIL

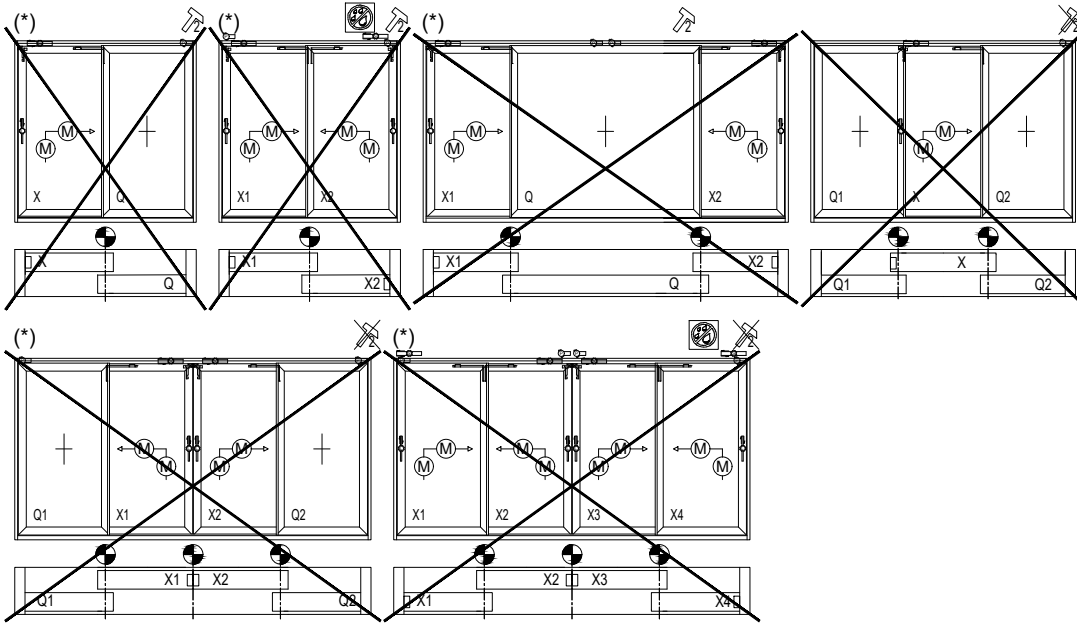

3-RAIL  
3-RAIL

3-RAIL  
3-RAIL

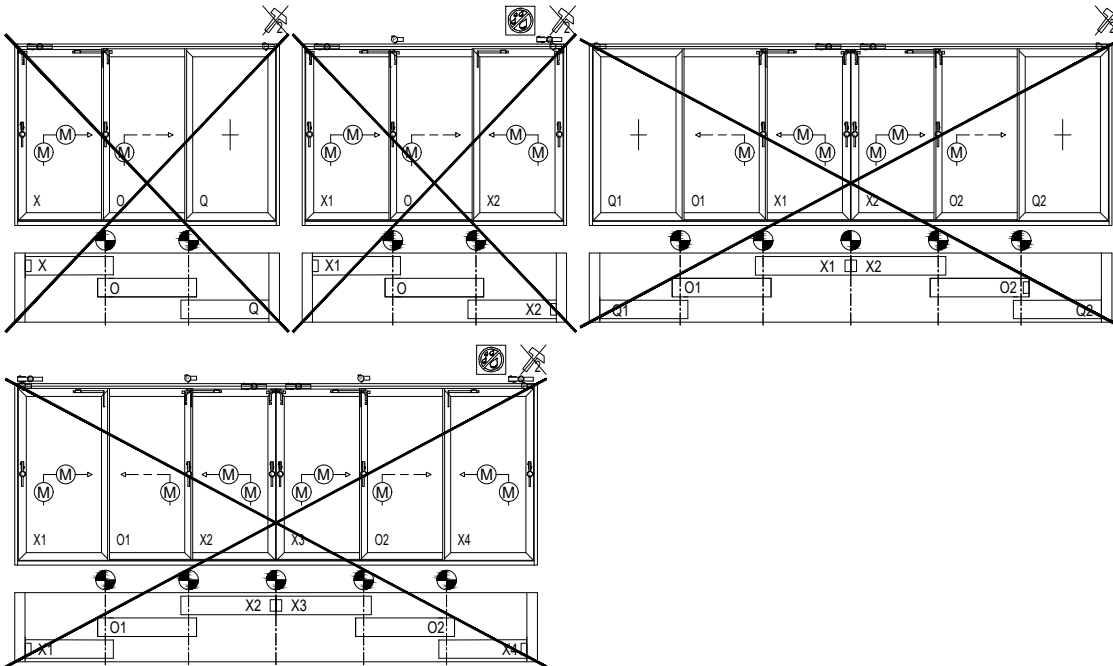

**!** BQ>BX VLEUGEL STAAT VLAK MET WISSELPROFIEL IN OPEN POSITIE  
 BQ>BX L'OUVRANT ÉGALE AU CHICANE EN POSITION OUVERTE  
 BQ>BX VENT FLUSH WITH MEETING SECTION IN OPEN POSITION  
 BQ>BX FLÜGEL IST FLACH MIT WECHSELPROFIL IN OFFENER POSITION

**!** FG MAX (X) ≤ 400 KG  
 FH MIN (X) ≥ 1645MM

**!** (\*) SMALLE CHICANE MOGELIJK (406.0330.XX) (OOK AP)  
 (\*) CHICANE ETROITE POSSIBLE (406.0330.XX) (AUSSI AP)  
 (\*) SLIM CHICANE POSSIBLE (406.0330.XX) (ALSO AP)  
 (\*) SCHMALE SCHIKANE MÖGLICH (406.0330.XX) (EBENFALLS AP)

**!** BX>1150MM & ≥650MM HORIZONTALE BEWEGING  
 BX>1150MM & ≥650MM MOVEMENT HORIZONTALE  
 BX>1150MM & ≥650MM HORIZONTAL MOVEMENT  
 BX>1150MM & ≥650MM HORIZONTALE VERSETZUNG

TRAINING CERTIFICERING VEREIST  
 ATTESTE DE CERTIFICATION NECESSAIRE  
 TRAINING CERTIFICATION REQUIRED  
 SCHULUNG ZERTIFIZIERUNG ERFORDERLICH

MEER DETAILS BETREFFENDE ELEKTRISCHE SCHEMA'S ZIE ACCESS CONTROL  
 PLUS DE DETAILS CONCERNANT LES DIAGRAMMES ÉLECTRIQUES VOIR ACCESS CONTROL  
 MORE DETAILS REGARDING ELECTRICAL SCHEMES SEE ACCESS CONTROL  
 WEITERE DETAILS ZU ELEKTRISCHEN DIAGRAMMEN FINDEN SIE UNTER ACCESS CONTROL  
<https://www.reynaers.com/en/reynaers-customer-portal-nl>  
<https://www.reynaers.com/en/reynaers-customer-portal-fr>  
<https://www.reynaers.com/en/reynaers-customer-portal-en>  
<https://www.reynaers.com/en/reynaers-customer-portal-de>

**!** MEER DETAILS BETREFFENDE INSTALLATIE INSTRUCTIES ZIE "PRODUCT INFO" OP ARTIKEL WEBSITE (062.7300.--)  
 PLUS DE DETAILS CONCERNANT LES INSTRUCTIONS D'INSTALLATION VOIRE "PRODUCT INFO" SUR ARTICLE SITE DE WEB (062.7300.--)  
 MORE DETAILS REGARDING INSTALLATION INSTRUCTIONS SEE "PRODUCT INFO" ON ARTICLE WEBSITE (062.7300.--)  
 WEITERE DETAILS ZU INSTALLATIONSANWEISUNGEN FINDEN SIE UNTER "PRODUCT INFO" AUF DER ARTIKEL-WEBSITE (062.7300.--)

**SMLS OG1 / S2LS 1 / S2LS 8**

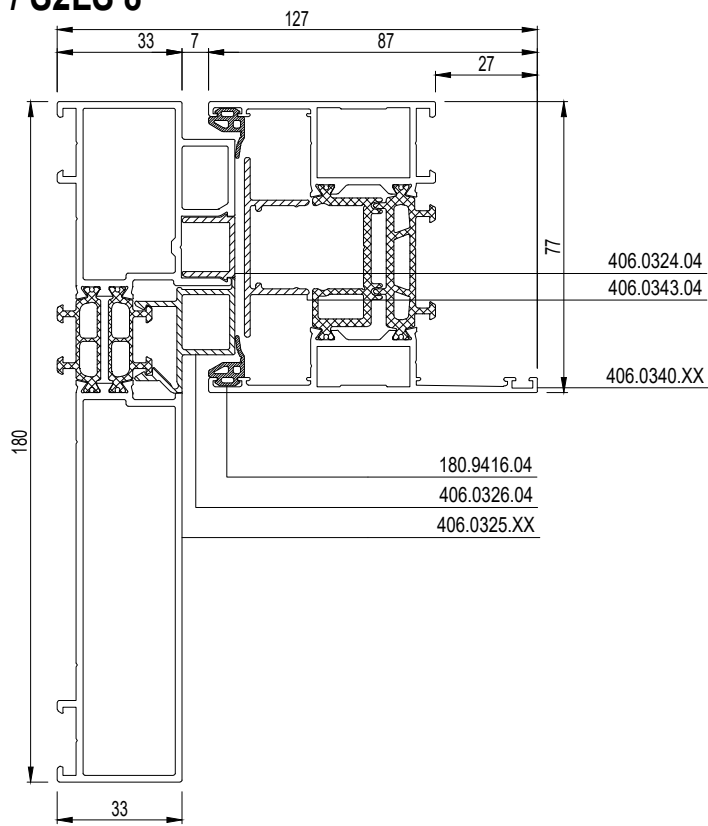

**SMLS OG2**

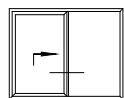
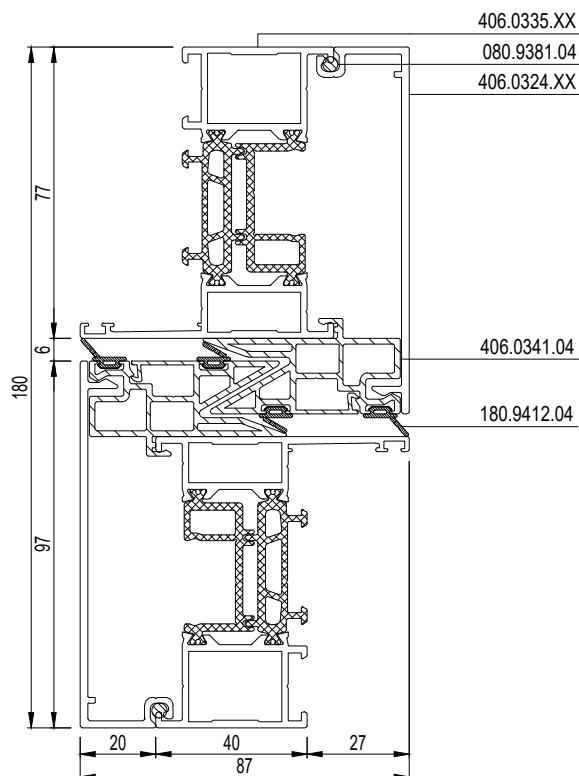

**SMLS OG1 / S2LS 1 / S2LS 8**

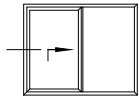
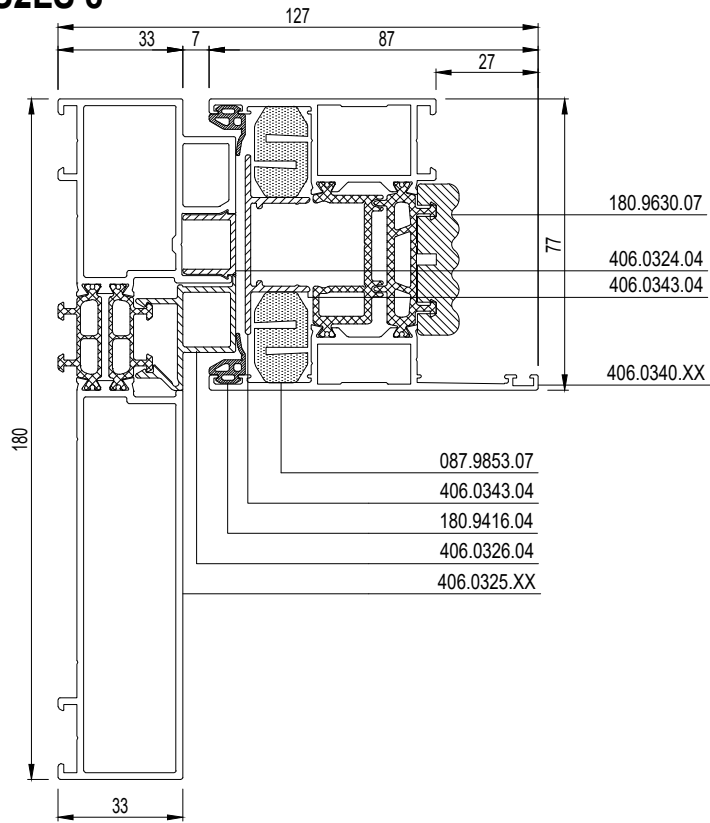

VARIANT HI  
 VARIANTE HI  
 VARIANT HI  
 VARIANT HI

**SMLS OG2**

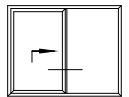
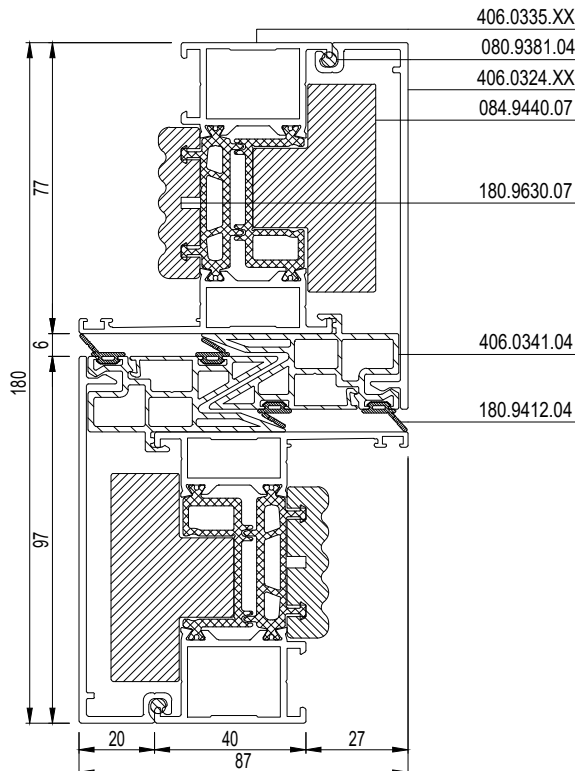

VARIANT HI  
 VARIANTE HI  
 VARIANT HI  
 VARIANT HI

**SMLS OG3 / SMLS IG3**

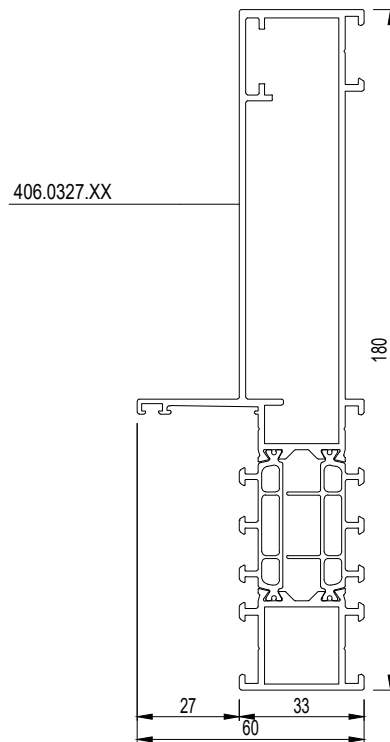
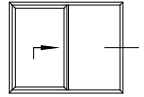

**SMLS OG4 / SMLS OG10**

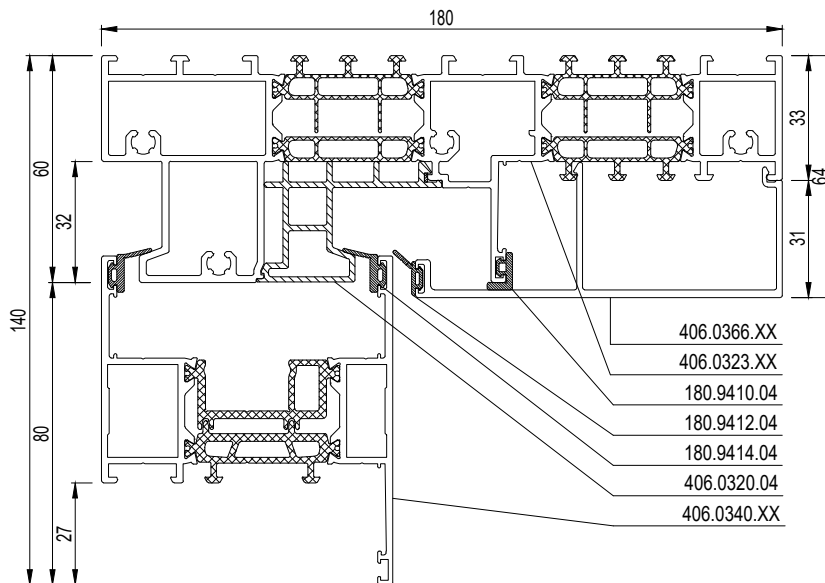
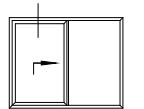

**SMLS OG3 / SMLS IG3**

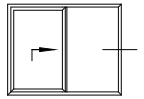

VARIANT HI  
 VARIANTE HI  
 VARIANT HI  
 VARIANT HI

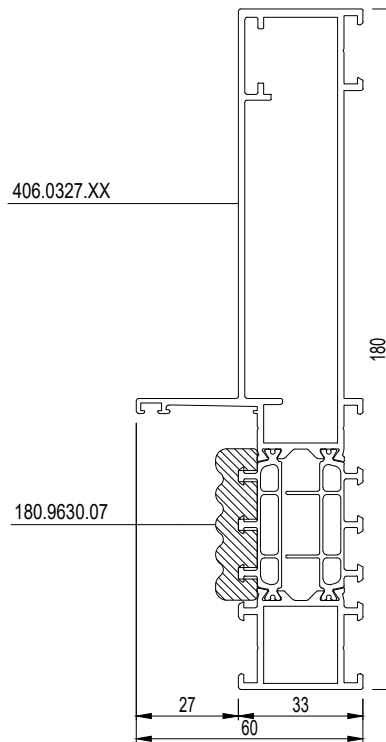

**SMLS OG4 / SMLS OG10**

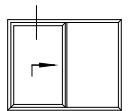

VARIANT HI  
 VARIANTE HI  
 VARIANT HI  
 VARIANT HI

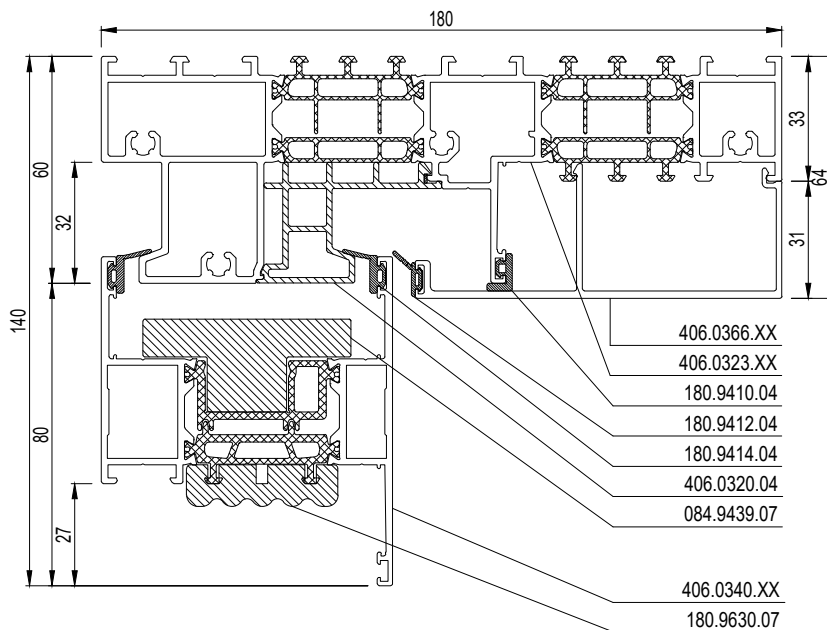

**SMLS OG5 / SMLS OG11**

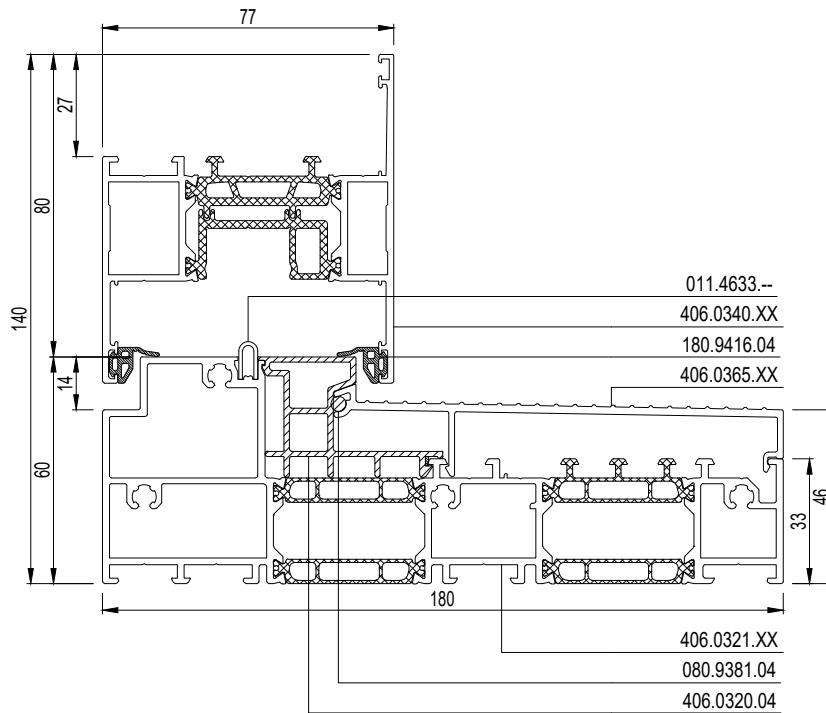
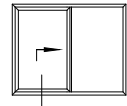

**SMLS OG6 / SMLS OG8 / SMLS OG14 / SMLS OG20 / SMLS IG6  
 SMLS IG8 / SMLS IG14**

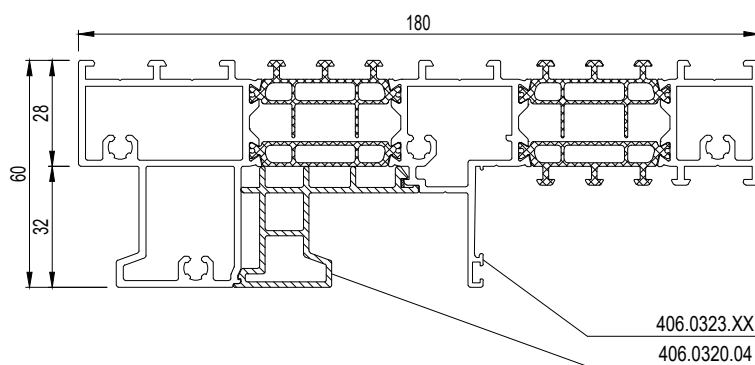
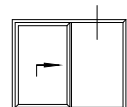

E

**SMLS OG5 / SMLS OG11**

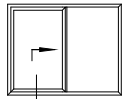
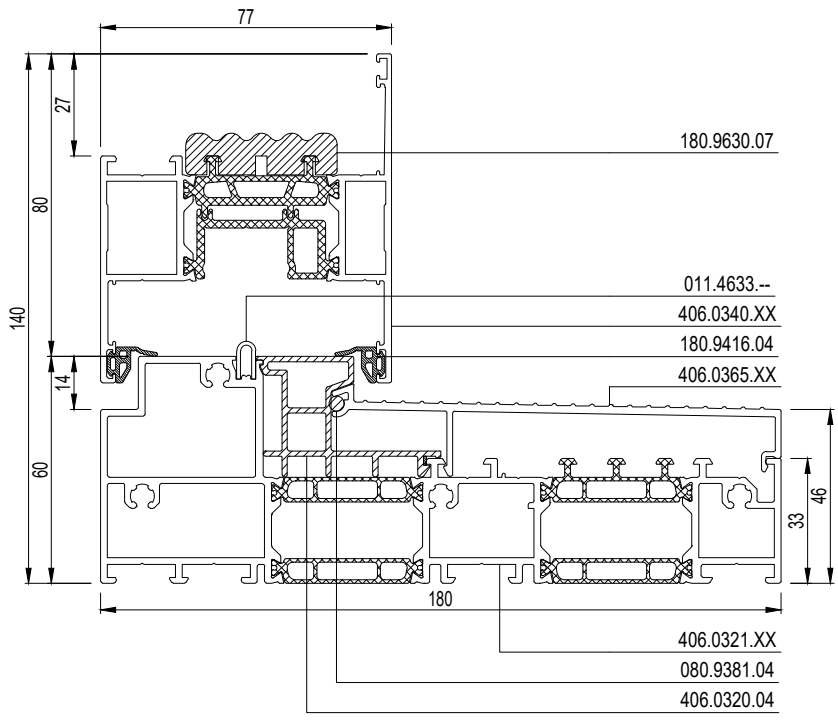

VARIANT HI  
 VARIANTE HI  
 VARIANT HI  
 VARIANT HI

**SMLS OG6 / SMLS OG8 / SMLS OG14 / SMLS OG20 / SMLS IG6  
 SMLS IG8 / SMLS IG14**

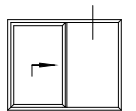
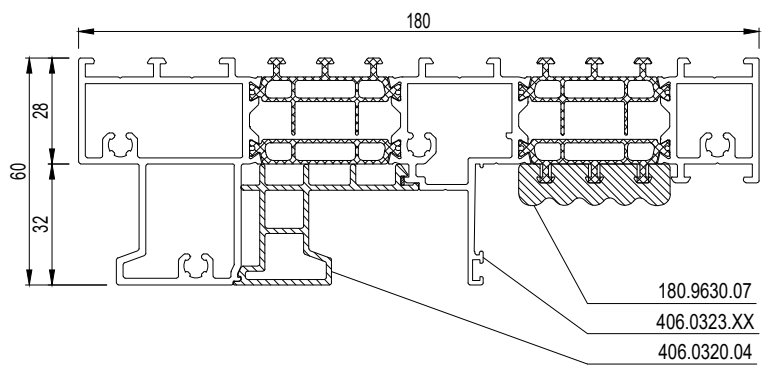

VARIANT HI  
 VARIANTE HI  
 VARIANT HI  
 VARIANT HI

E

**SMLS OG4 / SMLS OG10**

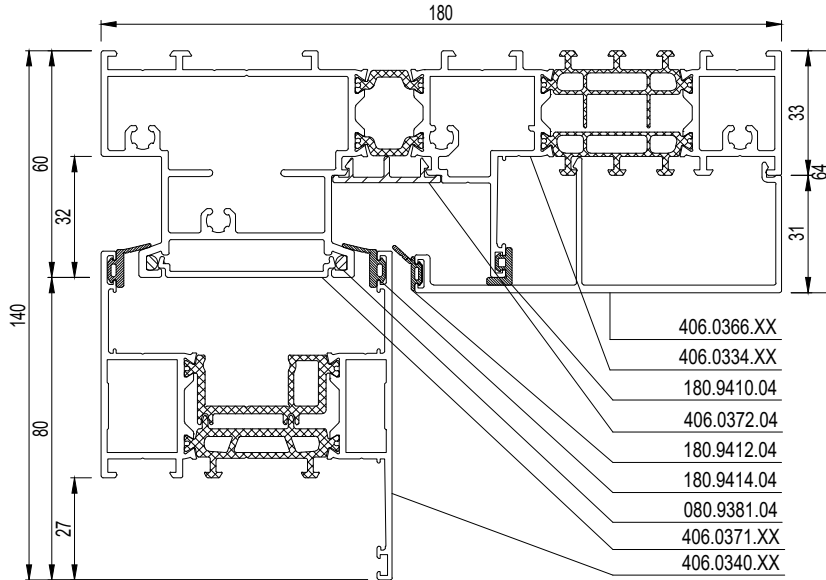
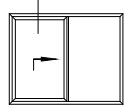

**SMLS OG6 / SMLS OG8 / SMLS OG14 / SMLS OG20 / SMLS IG6**  
**SMLS IG8 / SMLS IG14**

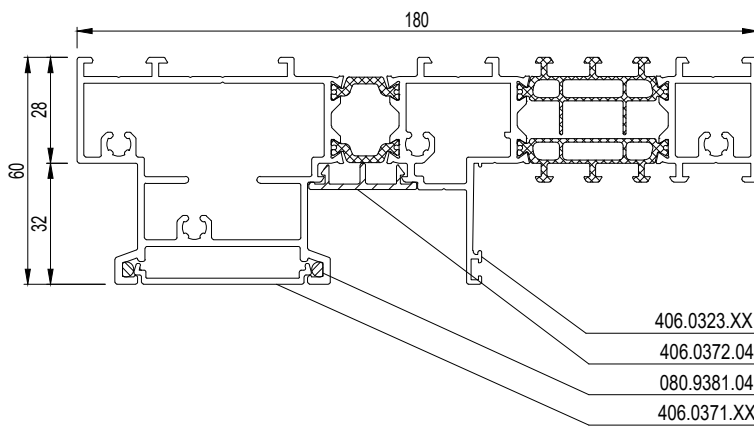
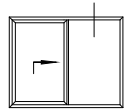

**SMLS OG4 / SMLS OG10**

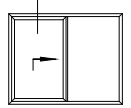

VARIANT HI  
VARIANTE HI  
VARIANT HI  
VARIANT HI

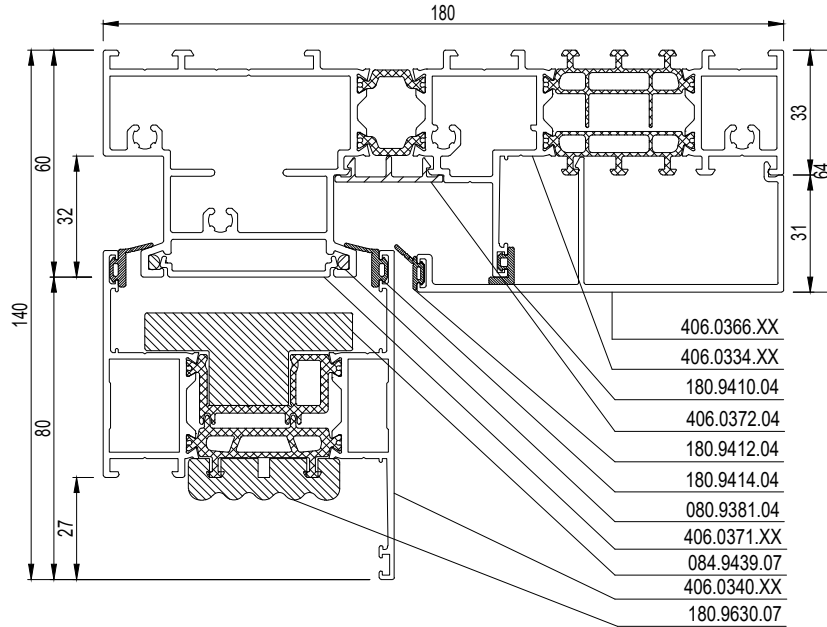

**SMLS OG6 / SMLS OG8 / SMLS OG14 / SMLS OG20 / SMLS IG6**  
**SMLS IG8 / SMLS IG14**

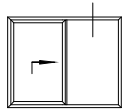

VARIANT HI  
VARIANTE HI  
VARIANT HI  
VARIANT HI

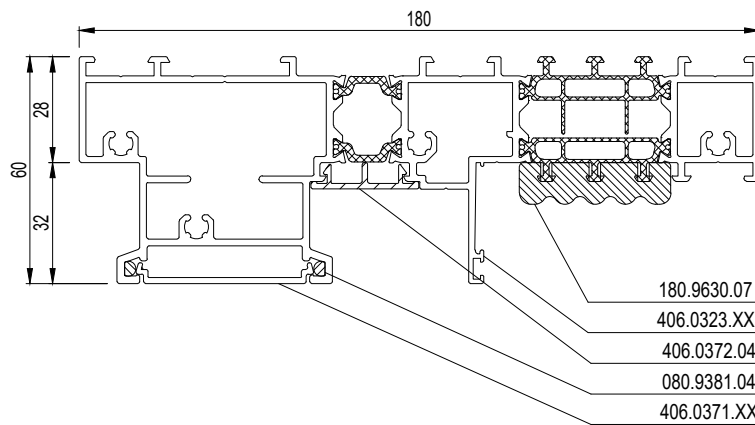

**SMLS OG7 / SMLS OG9 / SMLS OG15**

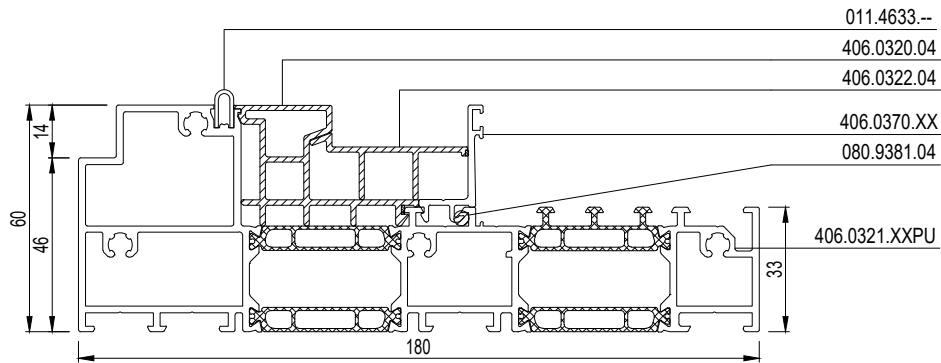
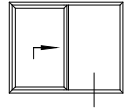

**SMLS IG7 / SMLS IG9 / SMLS IG15**

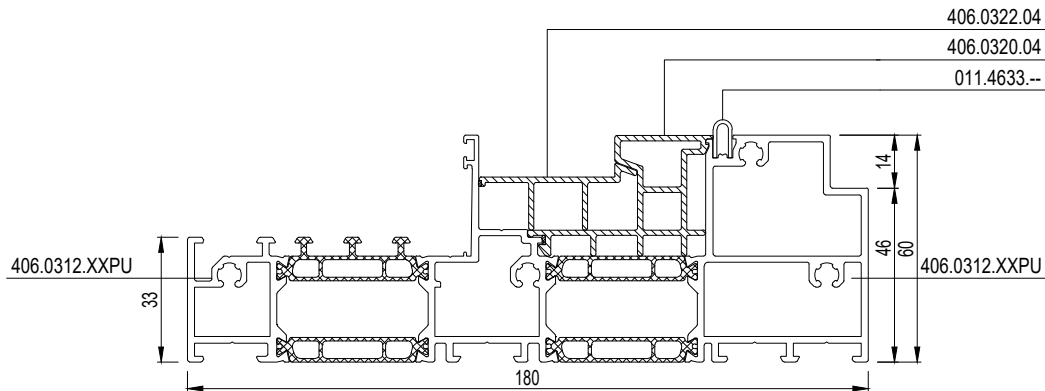
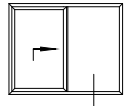

**SMLS OG7 / SMLS OG9 / SMLS OG15**

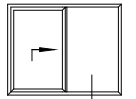

VARIANT HI  
 VARIANTE HI  
 VARIANT HI  
 VARIANT HI

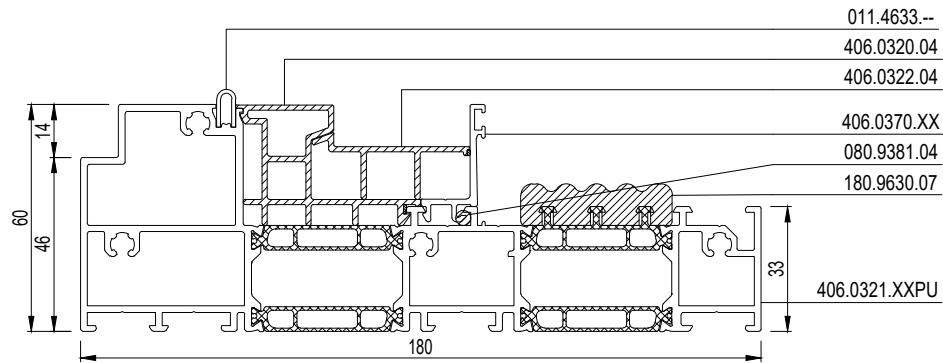

**SMLS IG7 / SMLS IG9 / SMLS IG15**

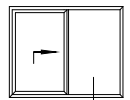

VARIANT HI  
 VARIANTE HI  
 VARIANT HI  
 VARIANT HI

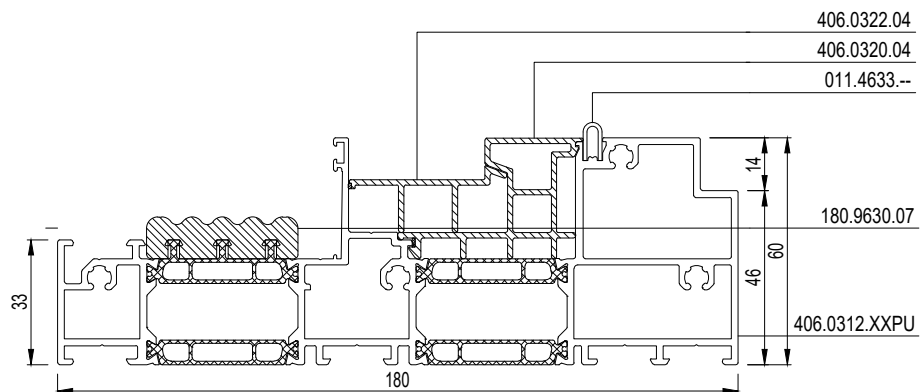

**SMLS OG12 / SMLS IG12 / S2LS 18 / S2LS 19 / S3LS 19 / S3LS 20**

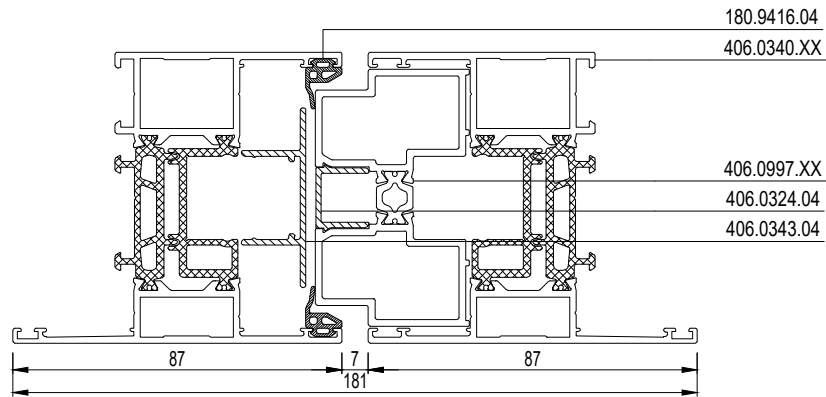
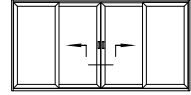

**SMLS OG18**

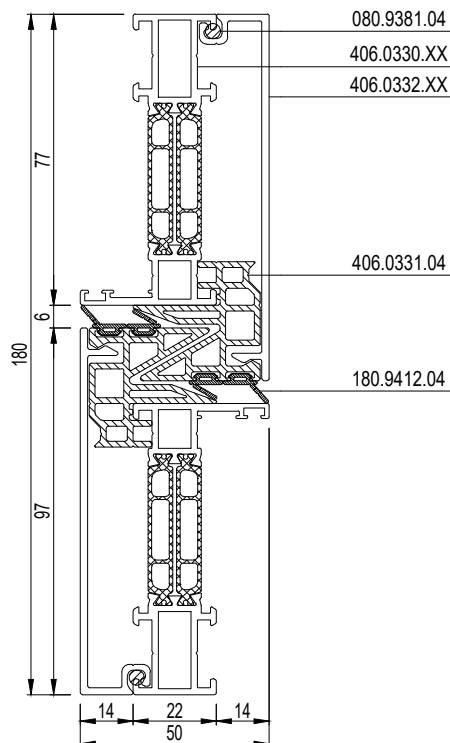
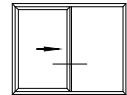

**SMLS OG12 / SMLS IG12 / S2LS 18 / S2LS 19 / S3LS 20**

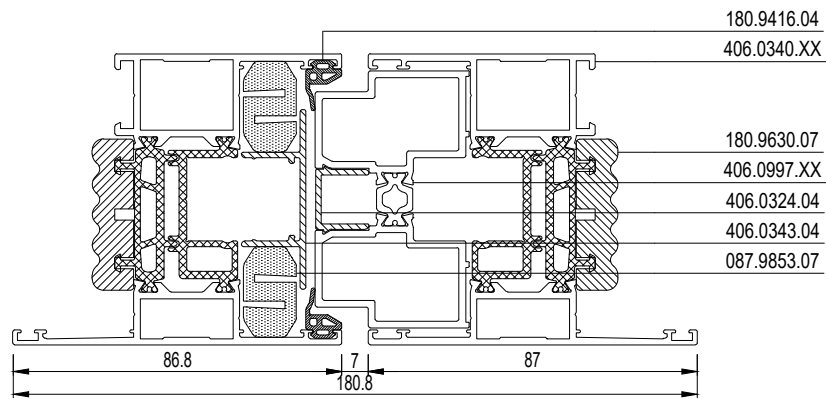
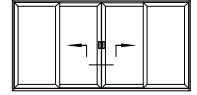

**SMLS OG18**

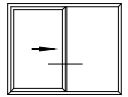

VARIANT HI  
 VARIANTE HI  
 VARIANTE HI  
 VARIANTE HI

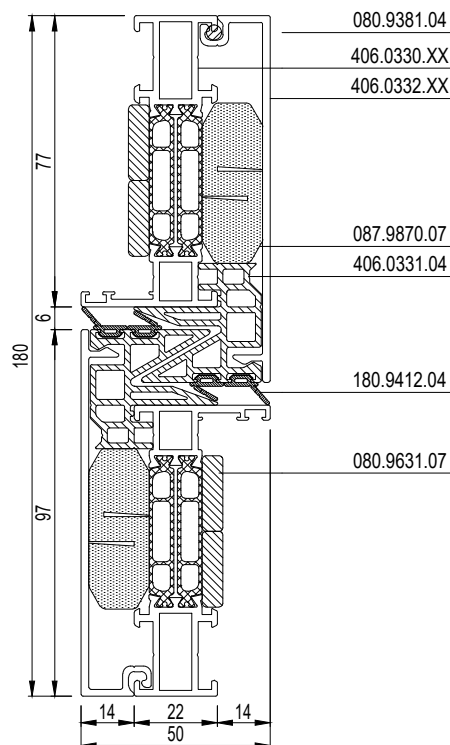

**SMLS OG19**

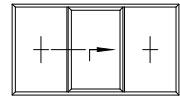
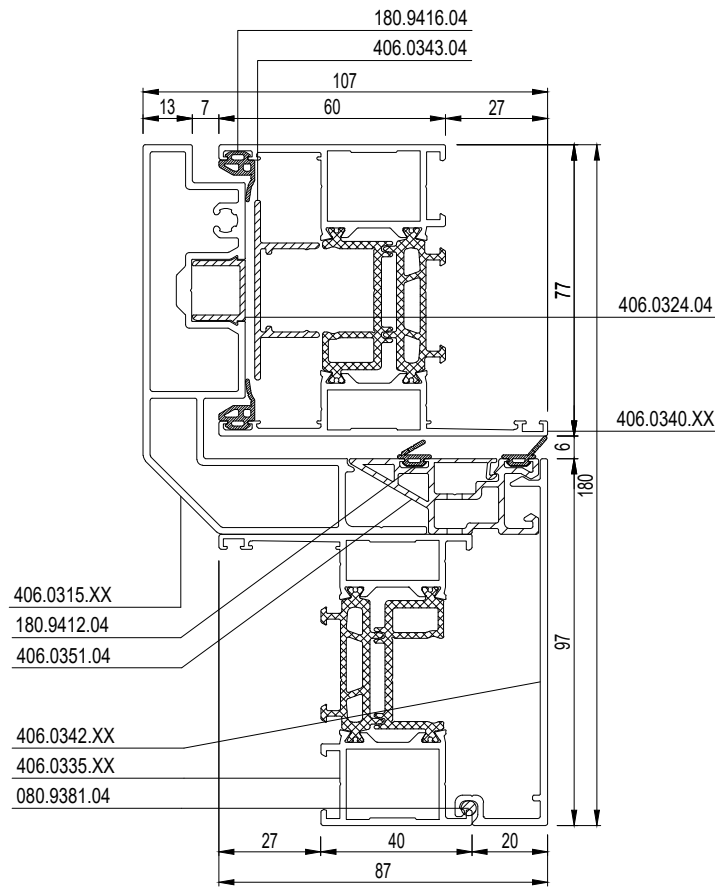

E

**SMLS OG19**

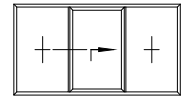
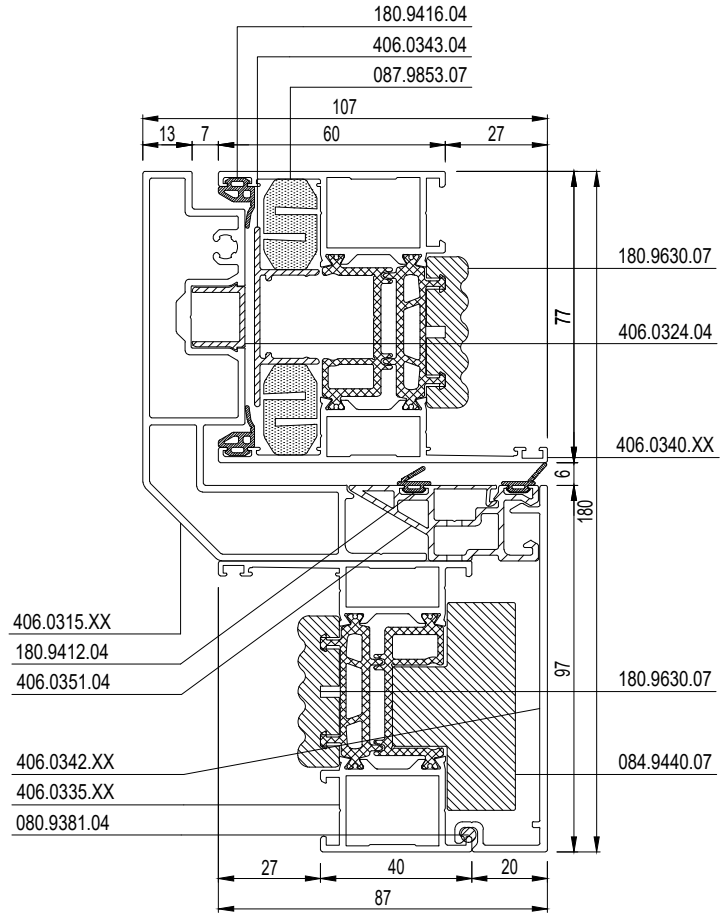

VARIANT HI  
 VARIANTE HI  
 VARIANT HI  
 VARIANT HI

## SMLS OG16 / SMLS OG21

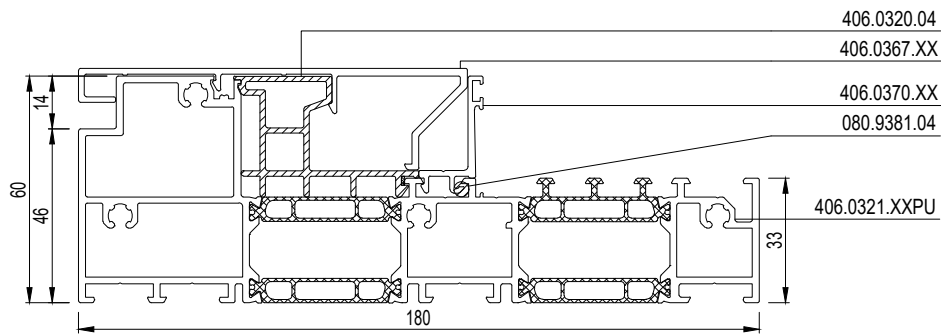
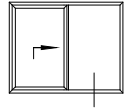

## SMLS IG16

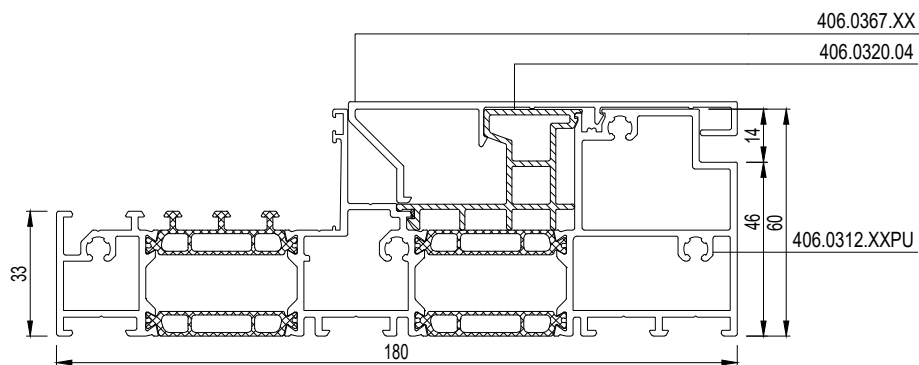
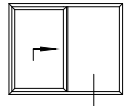

**SMLS OG16 / SMLS OG21**

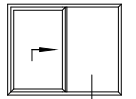

VARIANT HI  
 VARIANTE HI  
 VARIANT HI  
 VARIANT HI

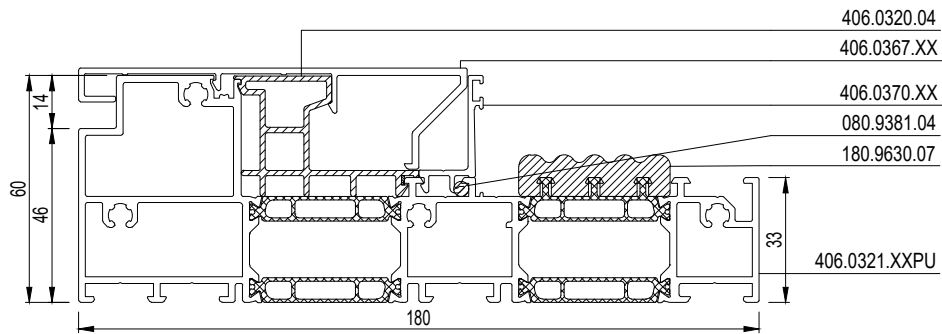

**SMLS IG16**

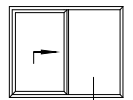

VARIANT HI  
 VARIANTE HI  
 VARIANT HI  
 VARIANT HI

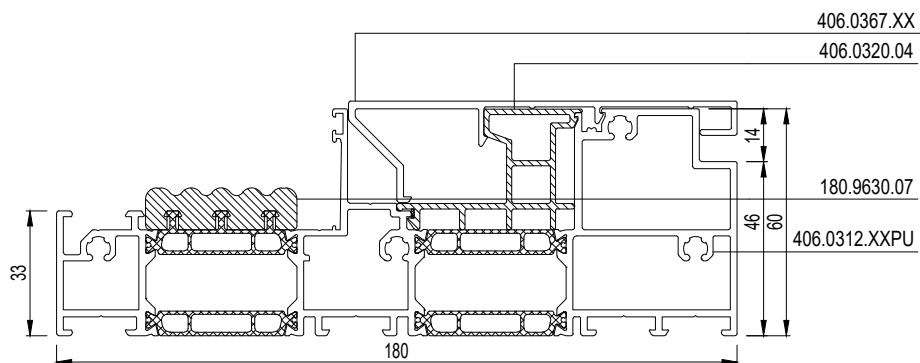

**SMLS IG1**

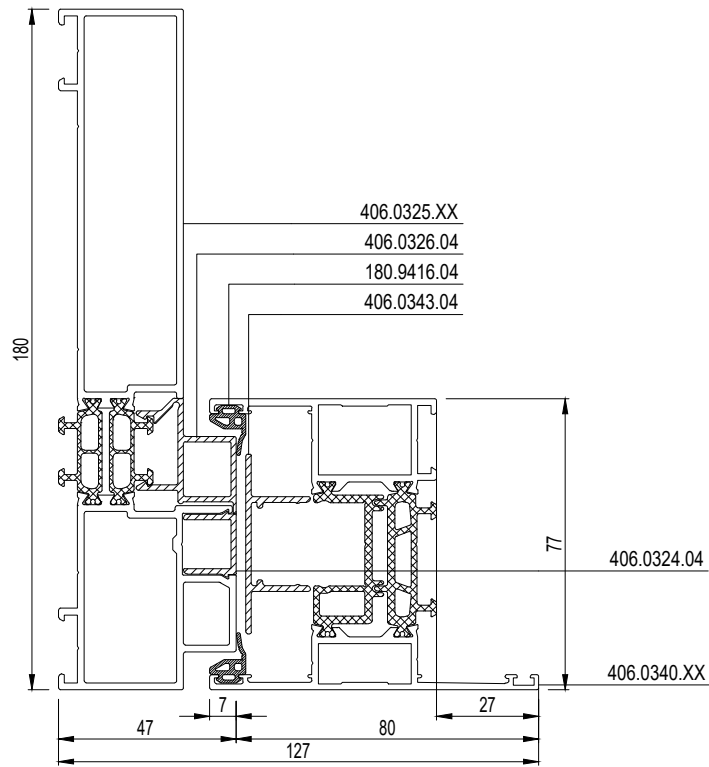
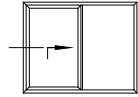

**SMLS IG2 / S2LS 2 / S2LS 9 / S3LS 2 / S3LS 3 / S3LS 12 / S3LS 13**

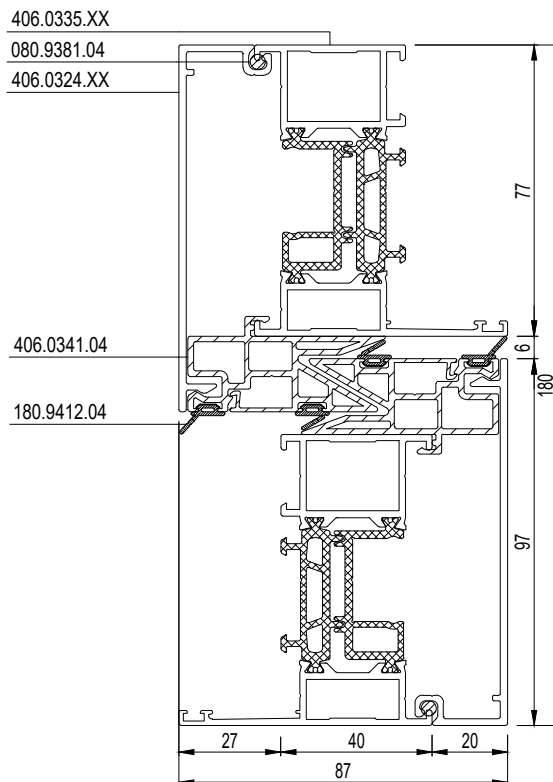
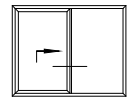

schaal - échelle  
 scale - Maßstab  
 1/2

**SMLS IG1**

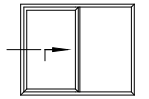

VARIANT HI  
 VARIANTE HI  
 VARIANT HI  
 VARIANT HI

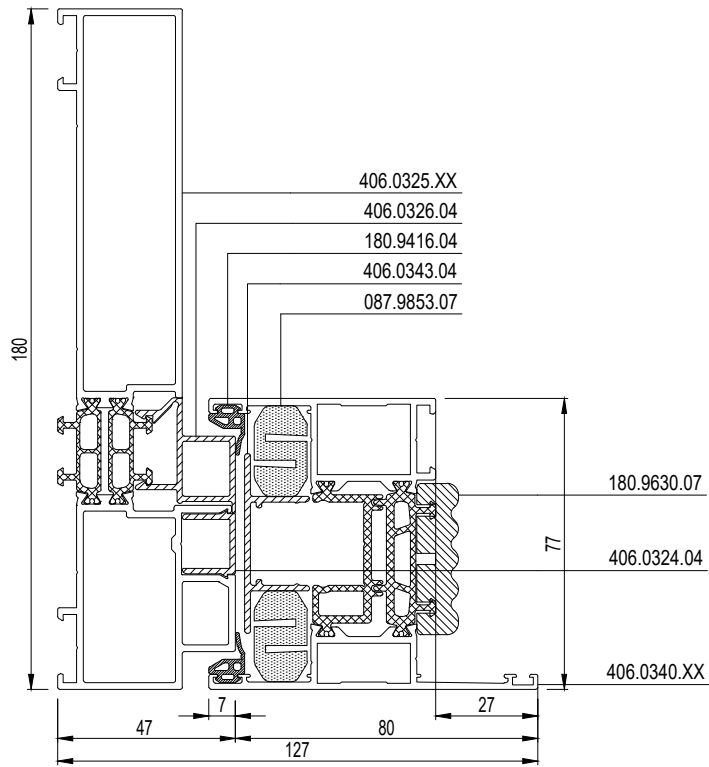

**SMLS IG2 / S2LS 2 / S2LS 9 / S3LS 2 / S3LS 3 / S3LS 12 / S3LS 13**

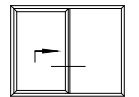

VARIANT HI  
 VARIANTE HI  
 VARIANT HI  
 VARIANT HI

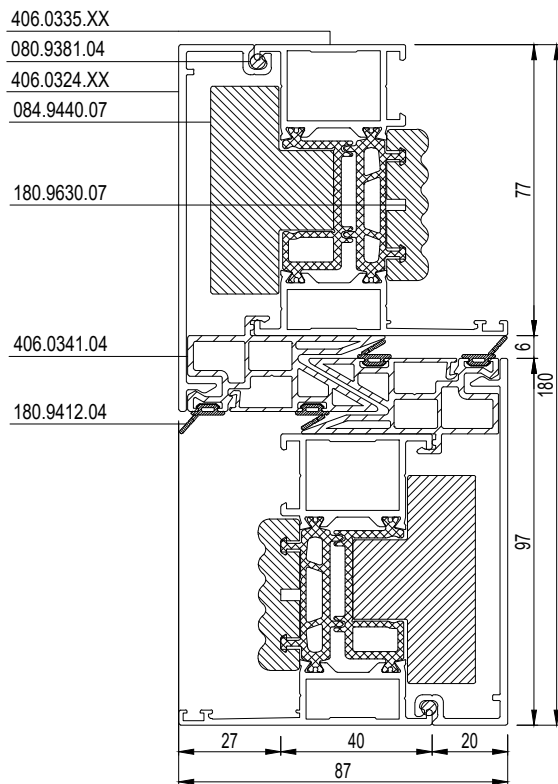

schaal - échelle  
 scale - Maßstab  
 1/2

**SMLS IG4 / SMLS IG10**

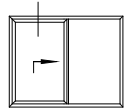
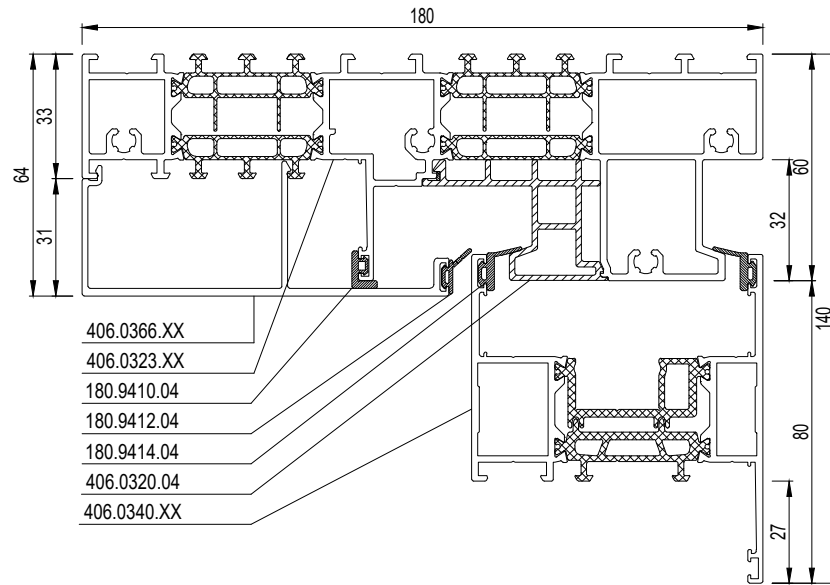

**SMLS IG5 / SMLS IG11**

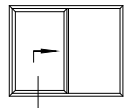
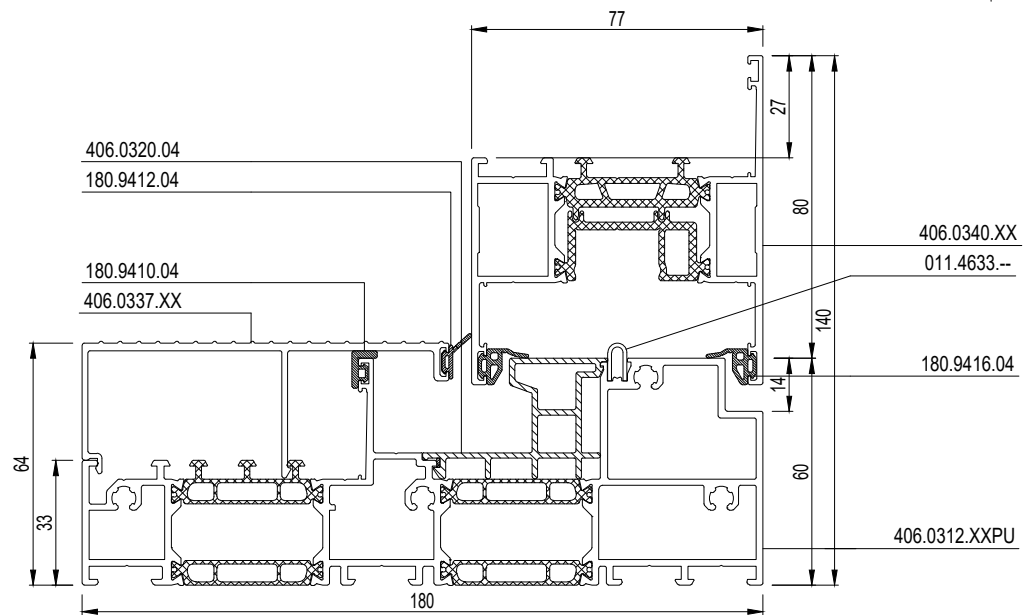

**SMLS IG4 / SMLS IG10**

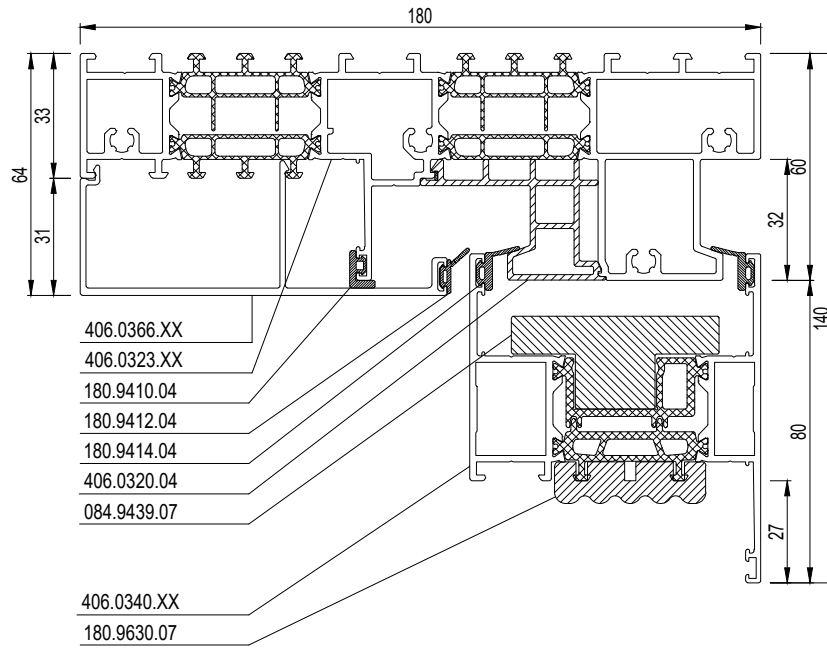

VARIANT HI  
 VARIANTE HI  
 VARIANT HI  
 VARIANT HI

**SMLS IG5 / SMLS IG11**

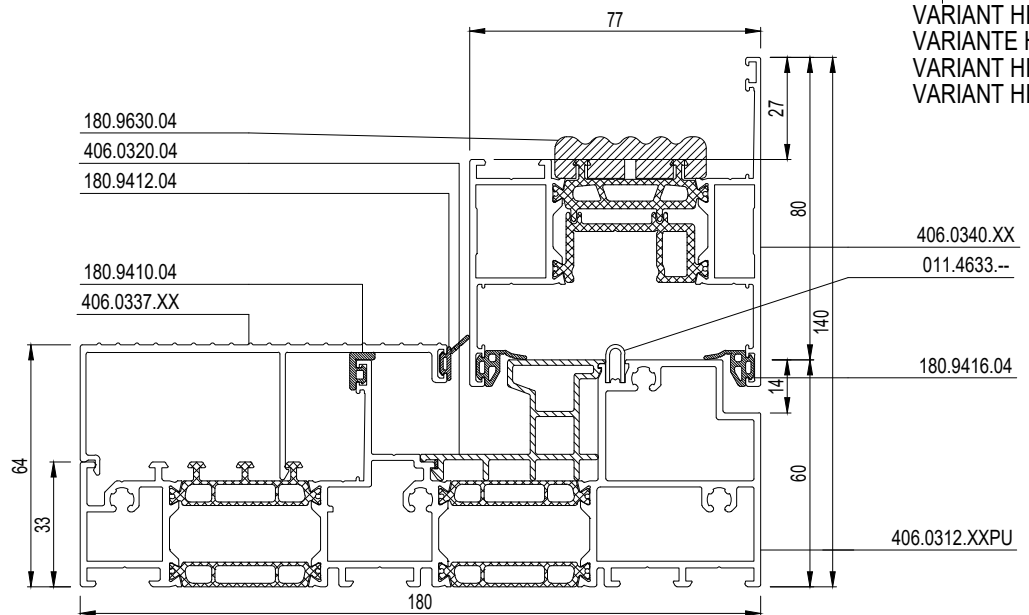

VARIANT HI  
 VARIANTE HI  
 VARIANT HI  
 VARIANT HI

## SMLS IG18 / S2LS 22

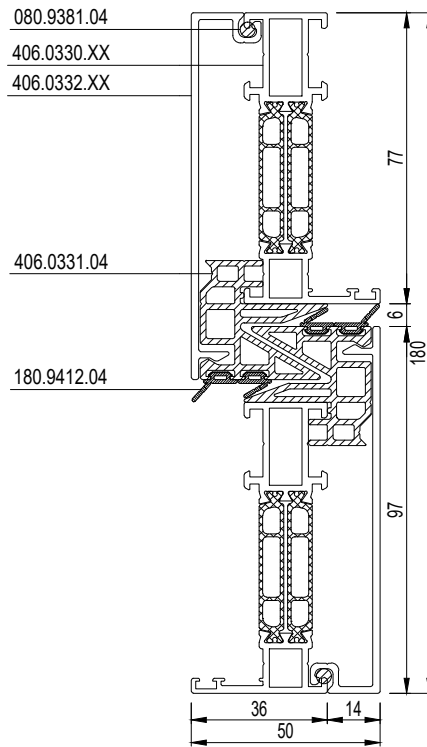
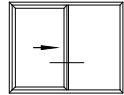

E

## SMLS IG18 / S2LS 22

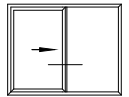

VARIANT HI  
VARIANTE HI  
VARIANT HI  
VARIANT HI

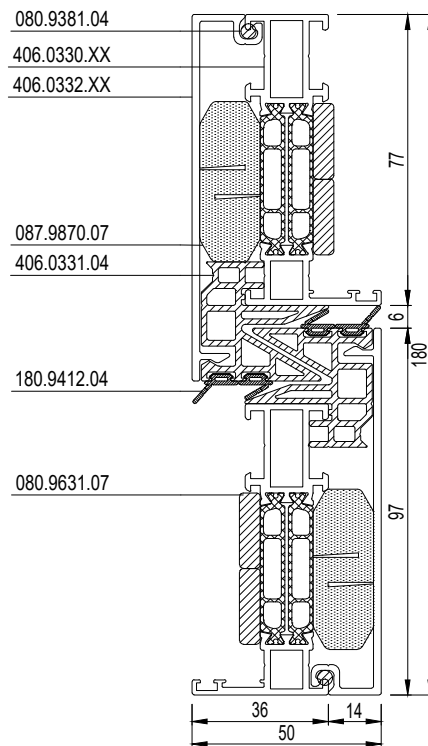

**SMLS IG4 / SMLS IG10**

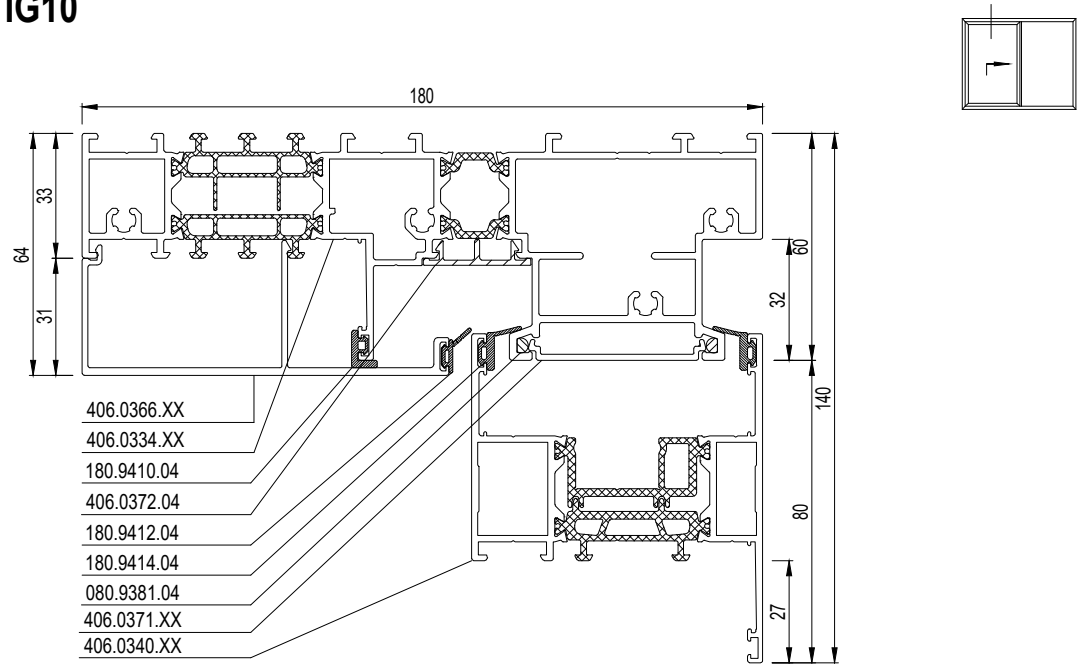

E

**SMLS IG4 / SMLS IG10**

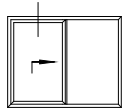
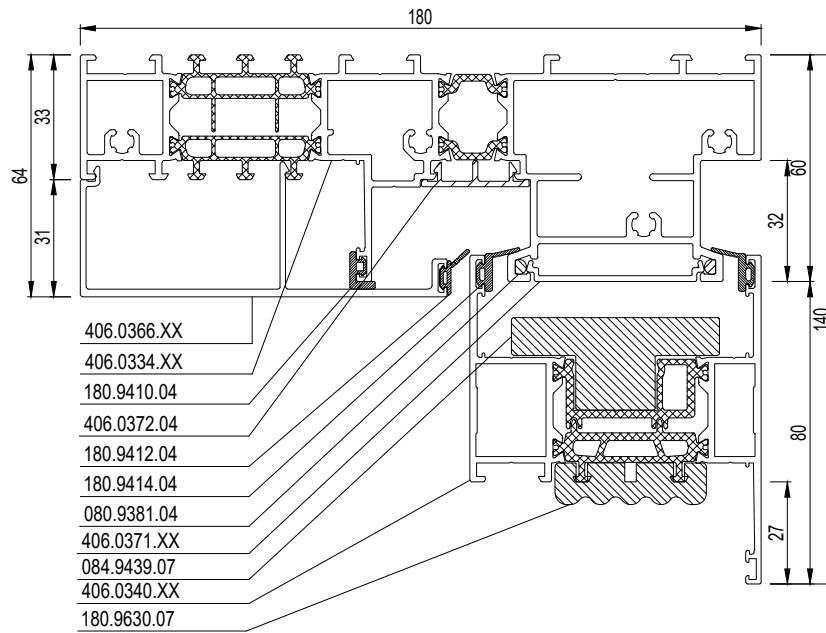

VARIANT HI  
VARIANTE HI  
VARIANT HI  
VARIANT HI

E

**S2LS 3**

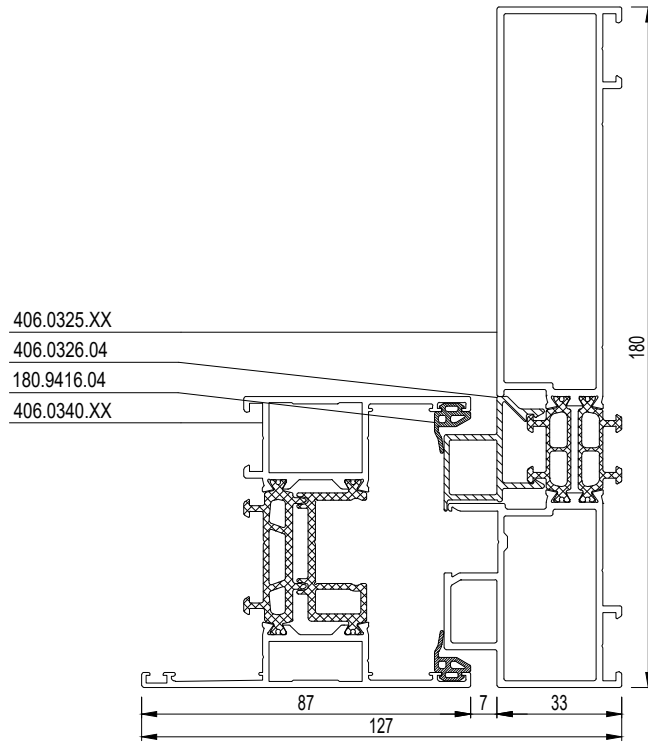
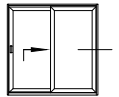

**S2LS 4 / S2SL16**

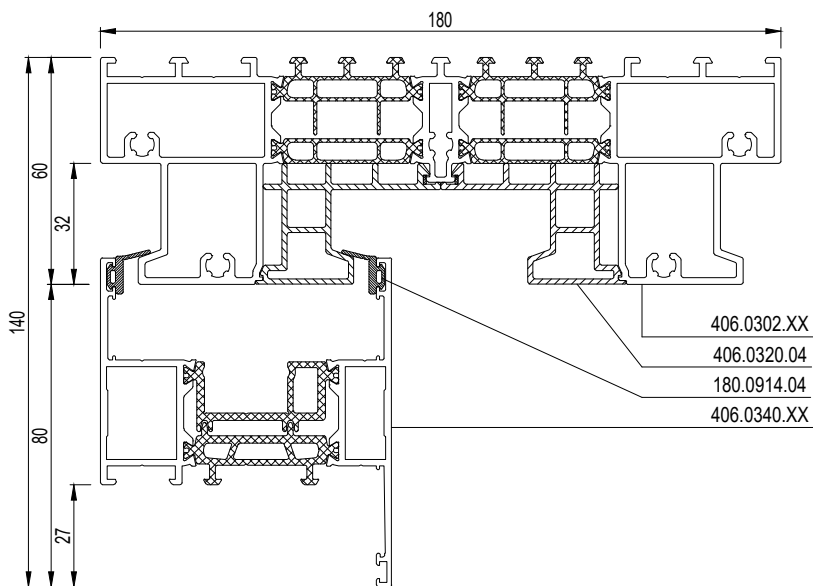
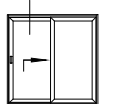

E

**S2LS 3**

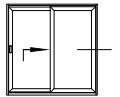

VARIANT HI  
 VARIANTE HI  
 VARIANT HI  
 VARIANT HI

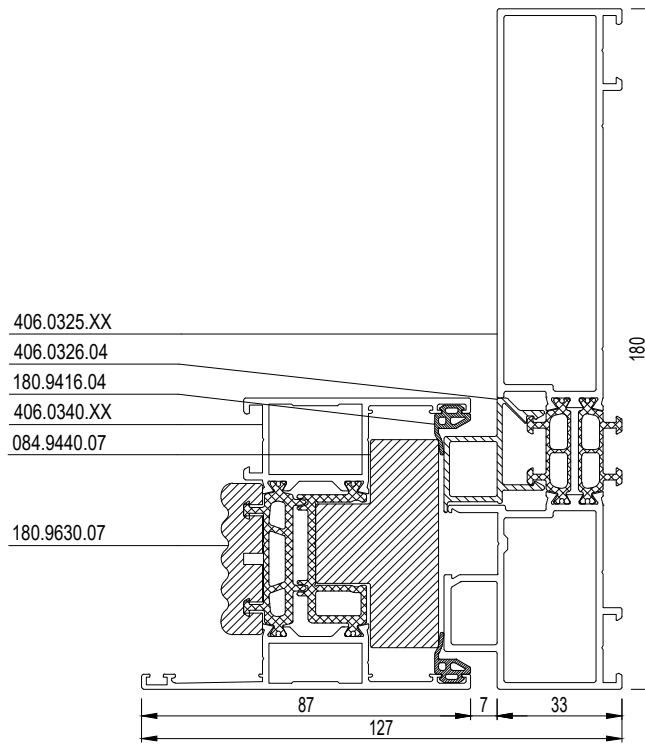

**S2LS 4 / S2SL16**

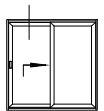

VARIANT HI  
 VARIANTE HI  
 VARIANT HI  
 VARIANT HI

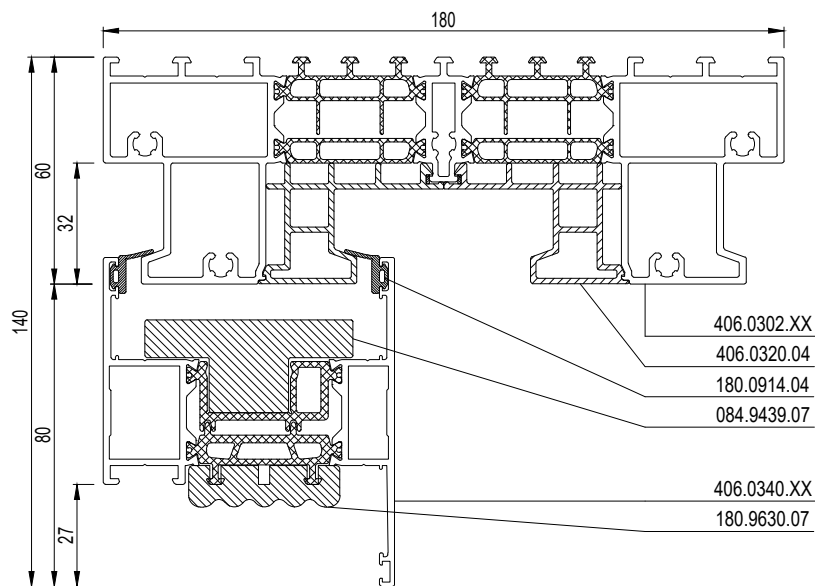

schaal - échelle  
 scale - Maßstab  
 1/2

**S2LS 5 / S2SL17**

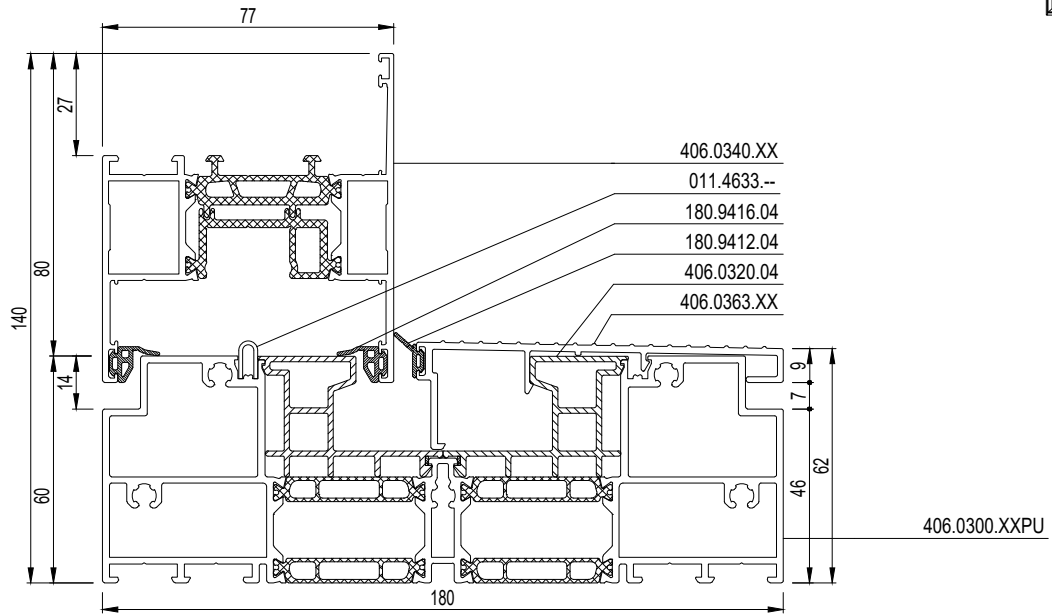
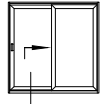

**S2LS 6 / S2LS 12 / S2LS 14 / S2LS 20 / S2LS 24**

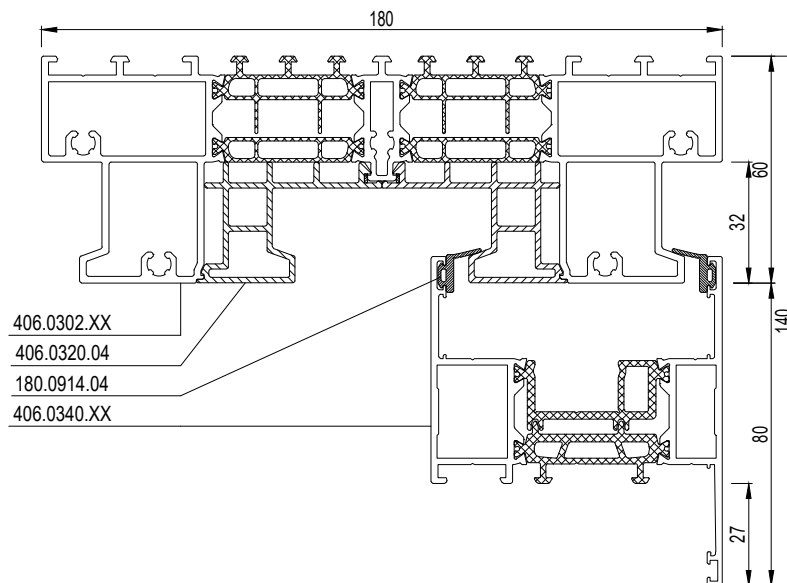
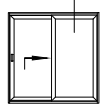

**S2LS 5 / S2SL17**

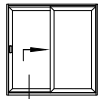
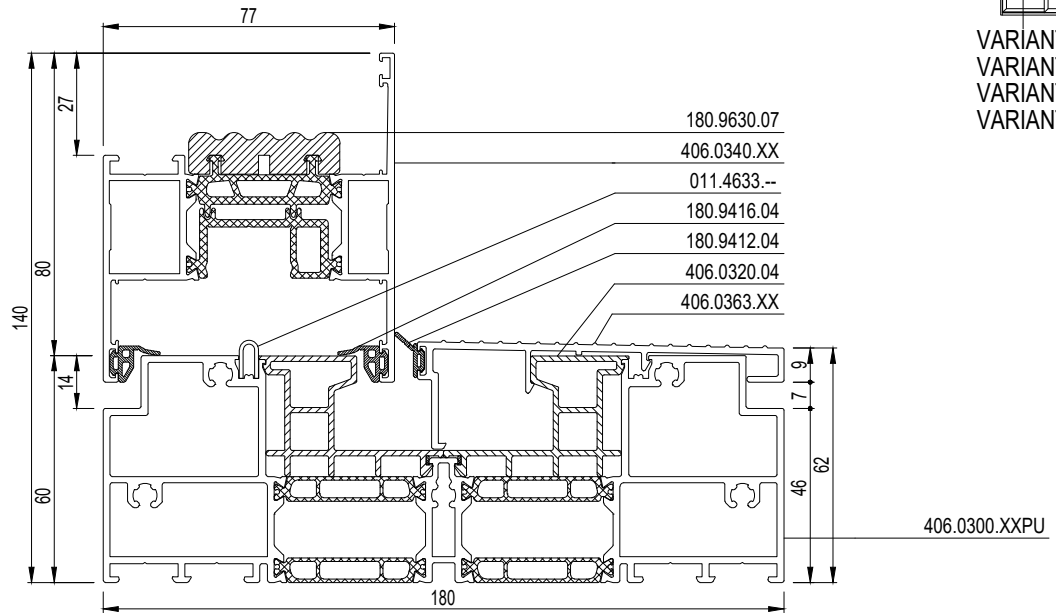

VARIANT HI  
 VARIANTE HI  
 VARIANT HI  
 VARIANT HI

**S2LS 6 / S2LS 12 / S2LS 14 / S2LS 20 / S2LS 24**

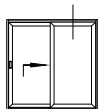
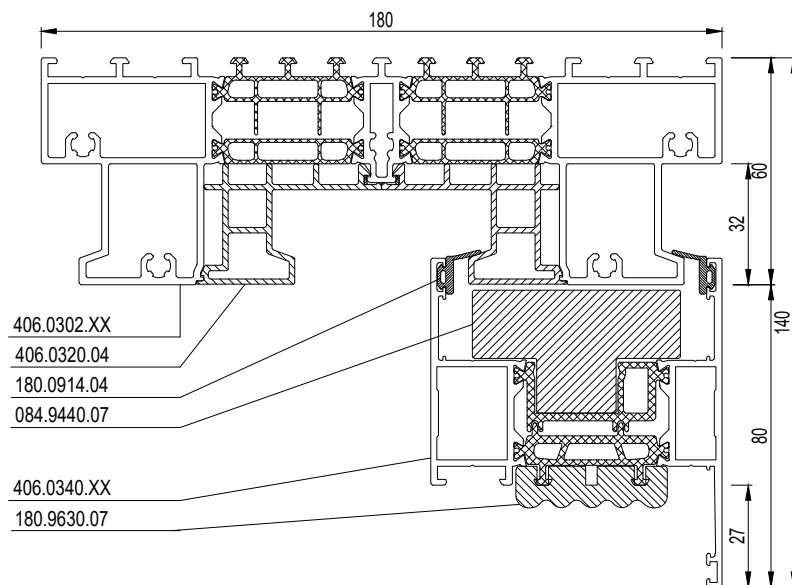

VARIANT HI  
 VARIANTE HI  
 VARIANT HI  
 VARIANT HI

E

S2LS 23

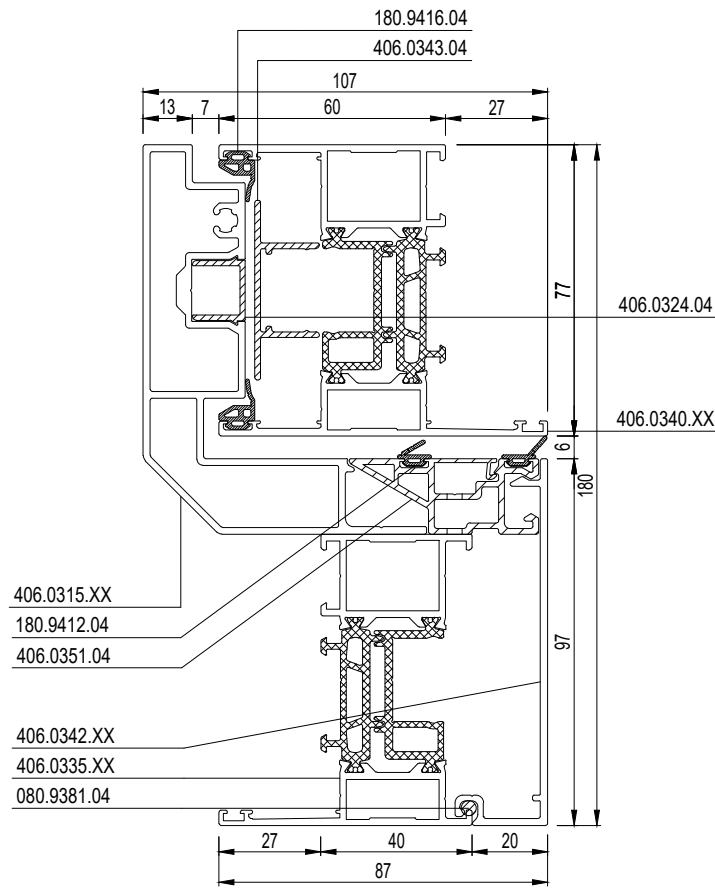

S2LS 25

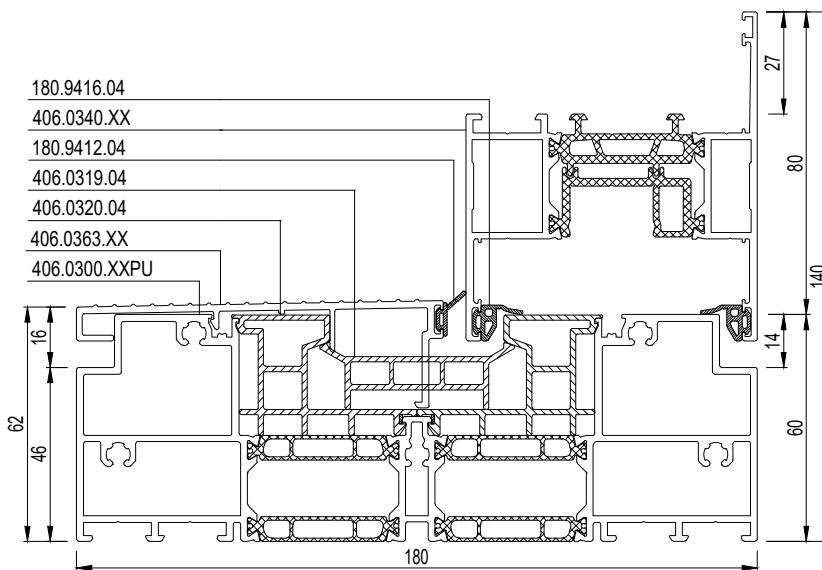

**S2LS 23**

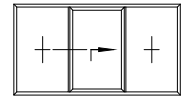
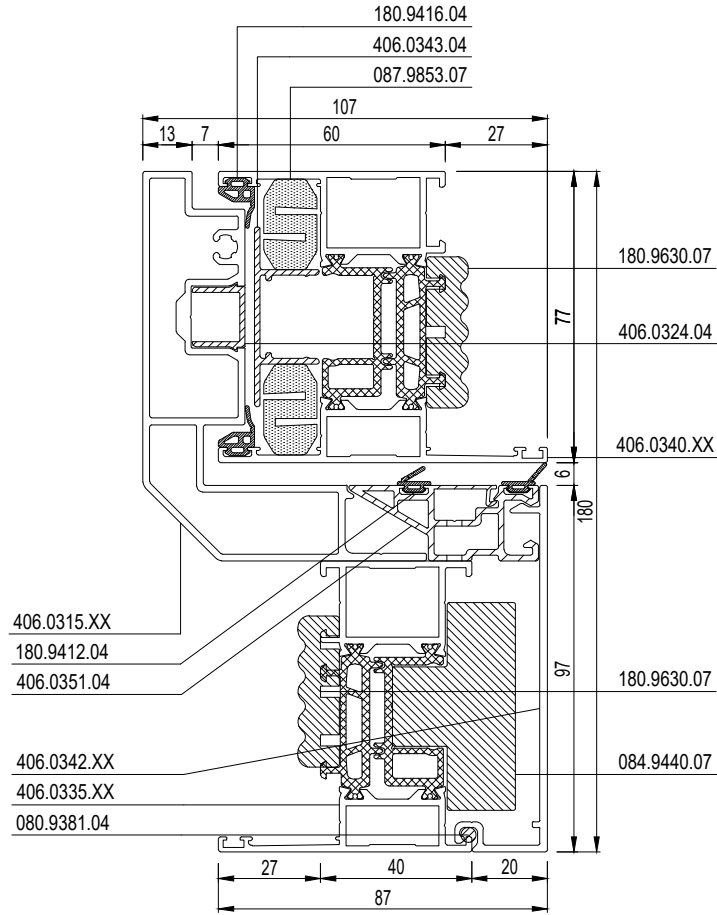

VARIANT HI  
 VARIANTE HI  
 VARIANT HI  
 VARIANT HI

**S2LS 25**

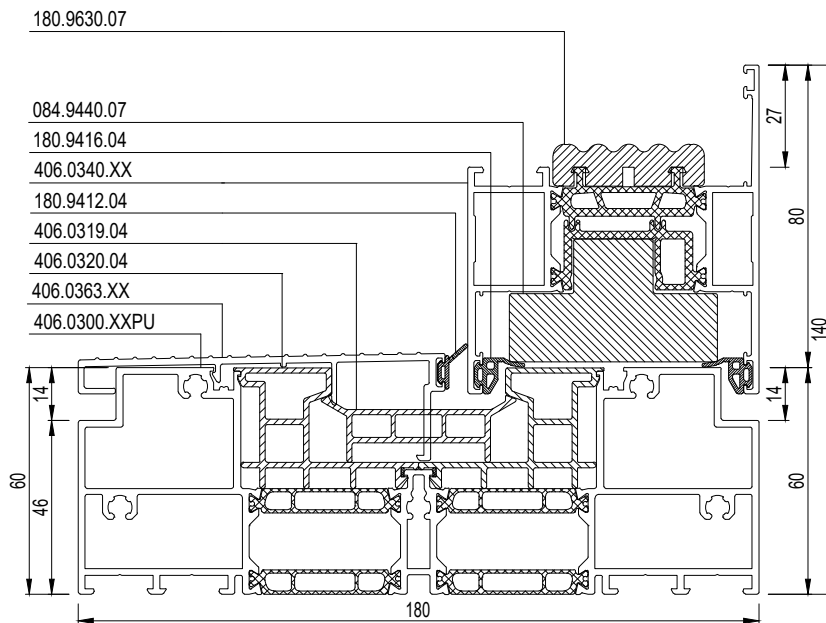

E

**S2LS 7 / S2LS 15**

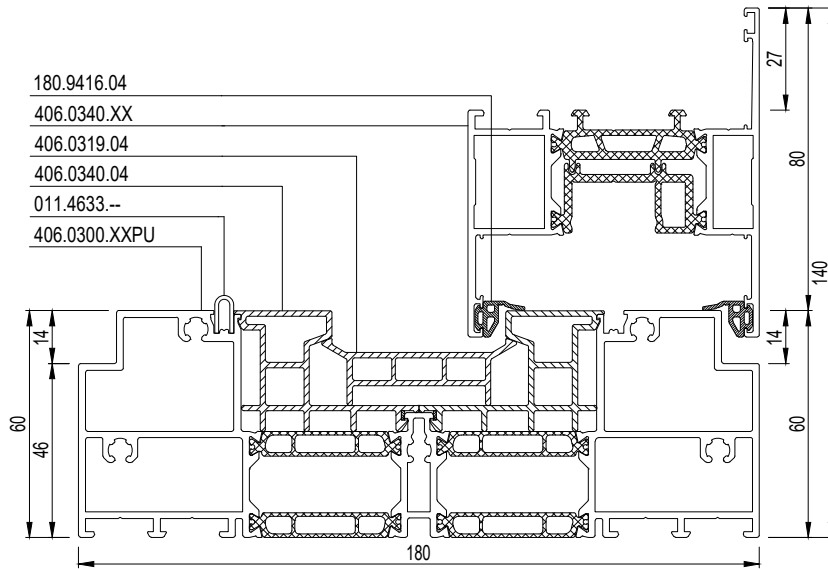
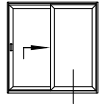

**S2LS 10**

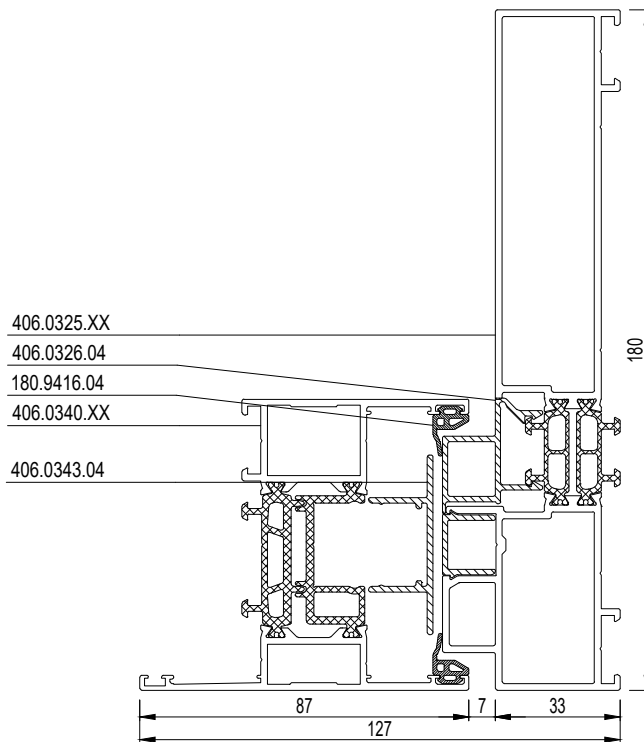
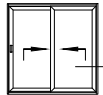

schaal - échelle  
 scale - Maßstab  
 1/2

**S2LS 7 / S2LS 15**

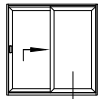
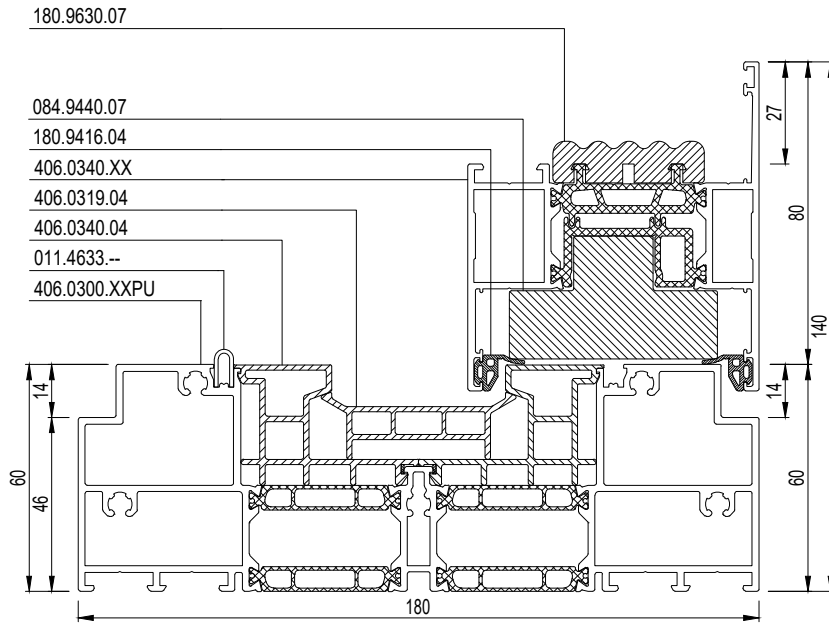

VARIANT HI  
 VARIANTE HI  
 VARIANT HI  
 VARIANT HI

**S2LS 10**

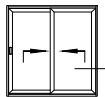
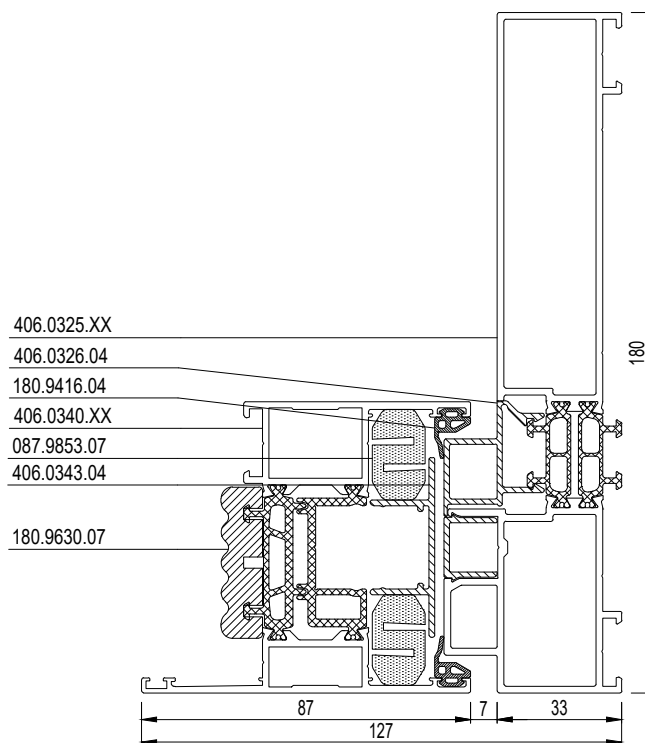

VARIANT HI  
 VARIANTE HI  
 VARIANT HI  
 VARIANT HI

**S2LS 11**

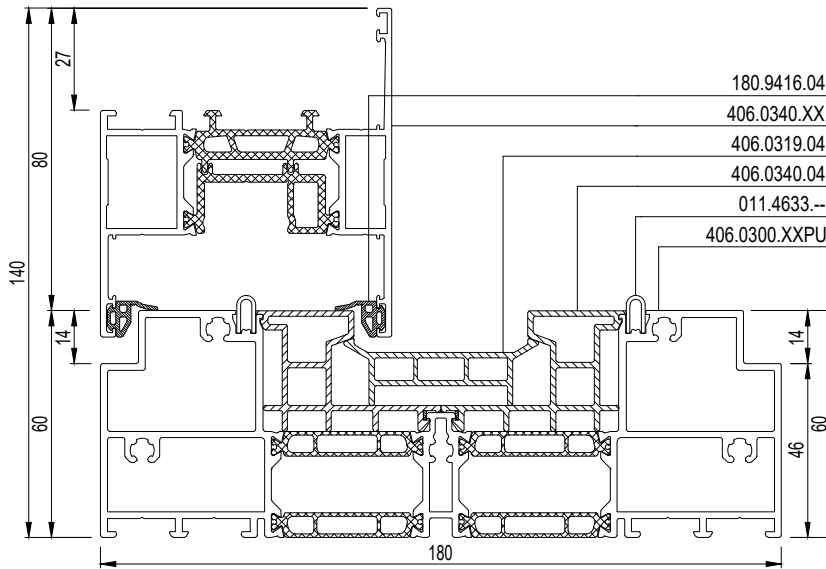
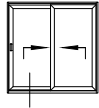

**S2LS 13/ S2LS 21**

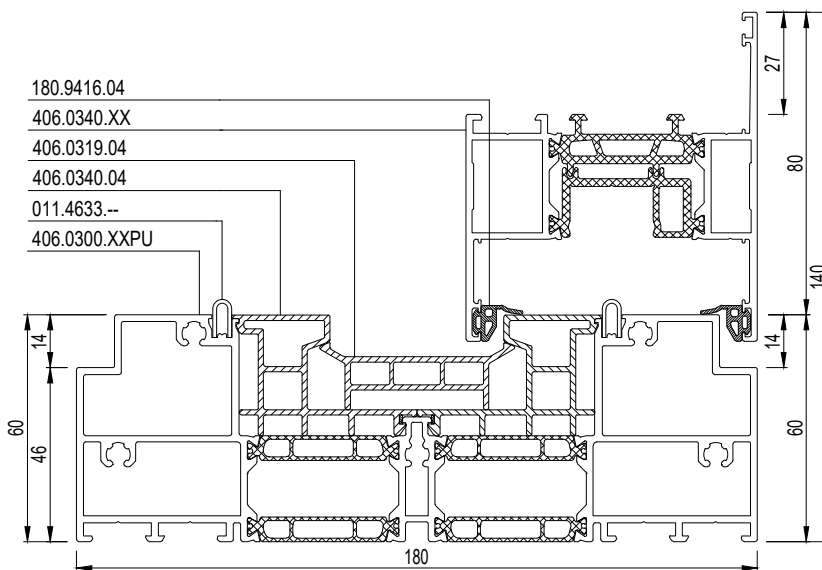
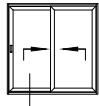

**S2LS 11**

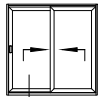

VARIANT HI  
 VARIANTE HI  
 VARIANT HI  
 VARIANT HI

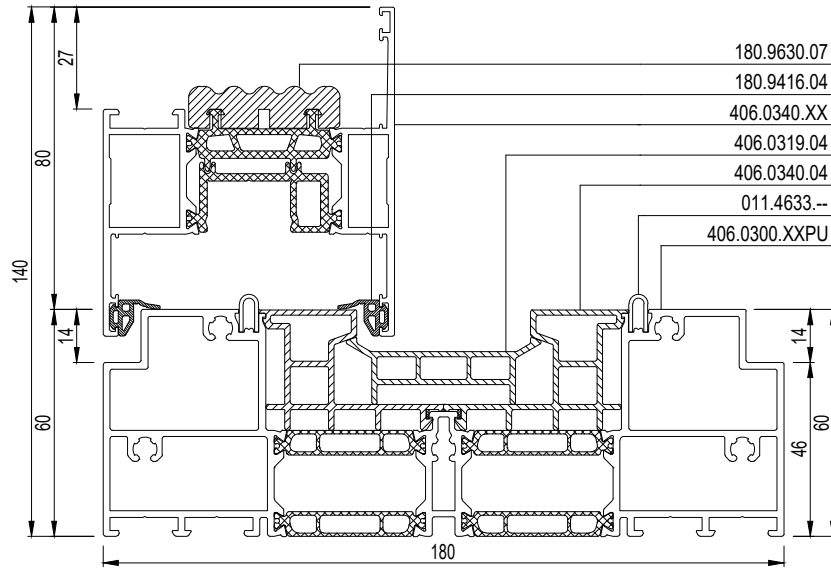

**S2LS 13/ S2LS 21**

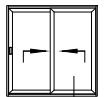

VARIANT HI  
 VARIANTE HI  
 VARIANT HI  
 VARIANT HI

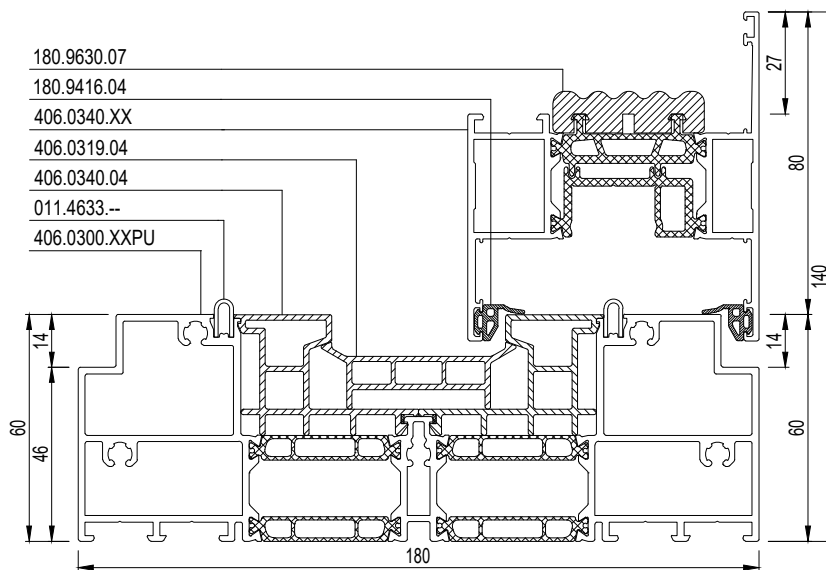

## S3LS 1 / S3LS 11

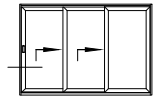
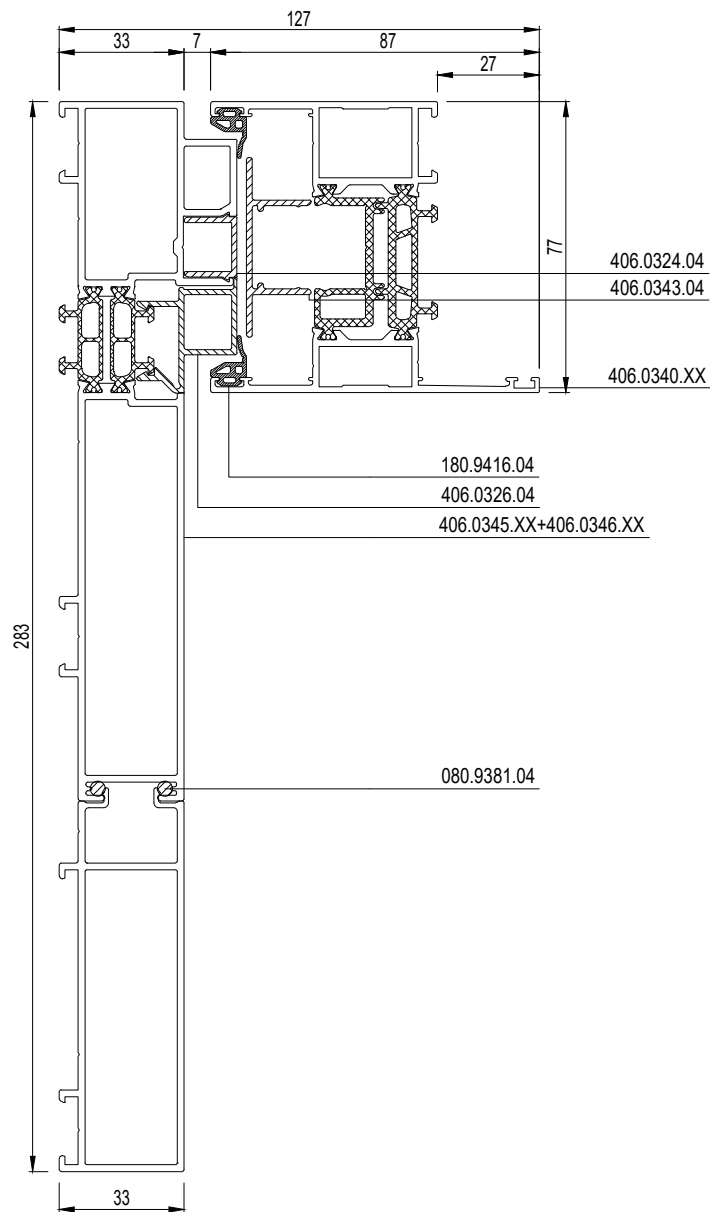

E

**S3LS 1 / S3LS 11**

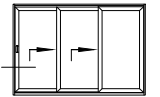
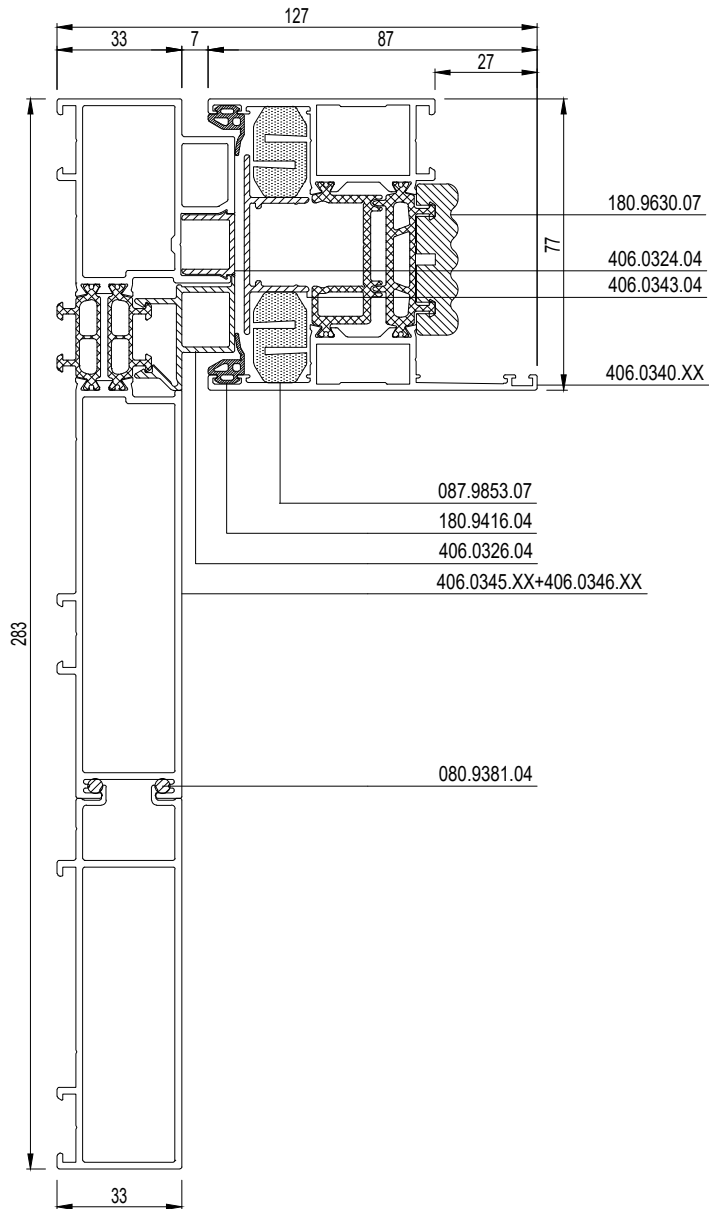

VARIANT HI  
 VARIANTE HI  
 VARIANT HI  
 VARIANT HI

E

## S3LS 4 / S3LS 14

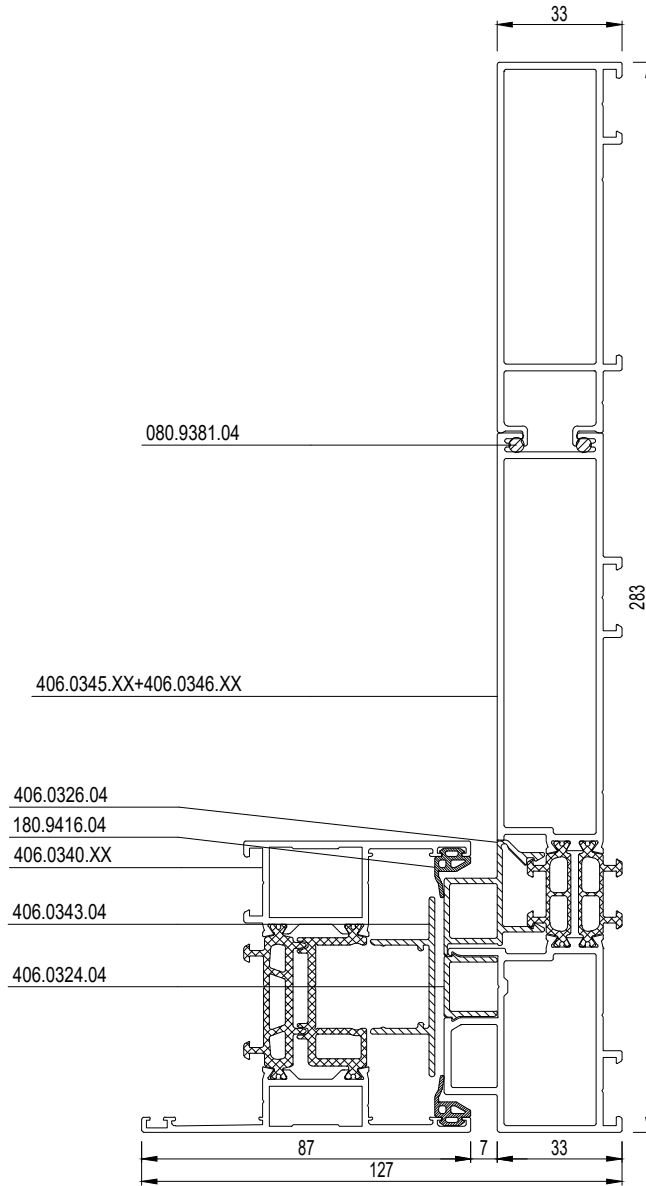
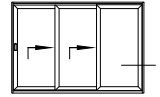

## S3LS 4 / S3LS 14

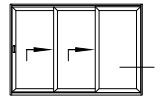

VARIANT HI  
VARIANTE HI  
VARIANT HI  
VARIANT HI

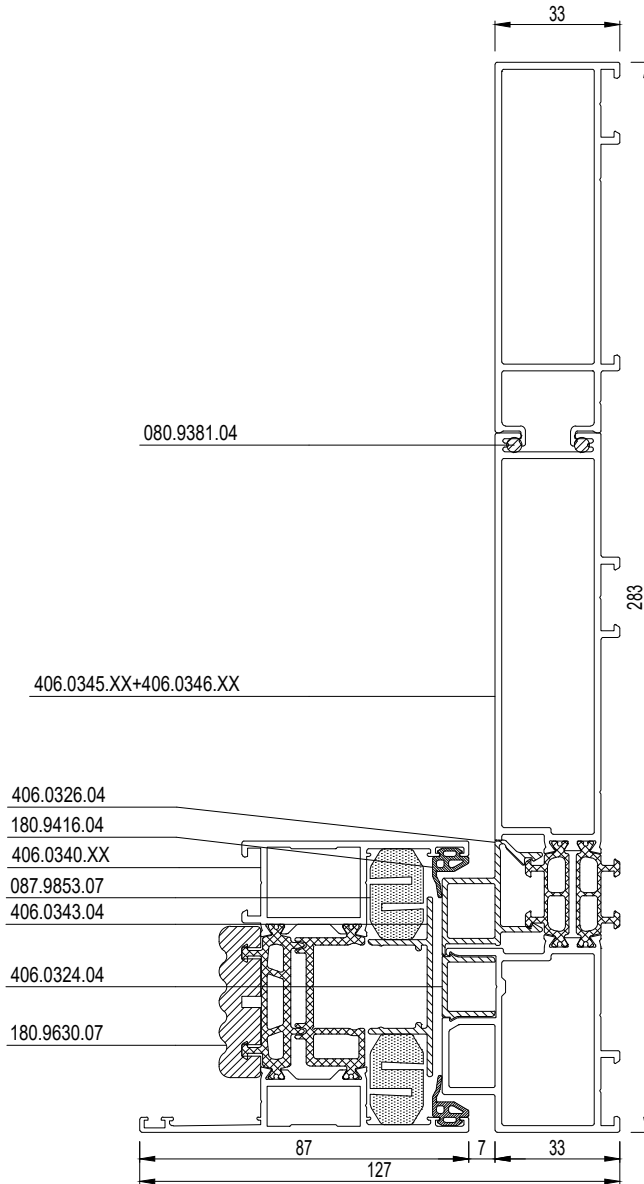

**S3LS 5**

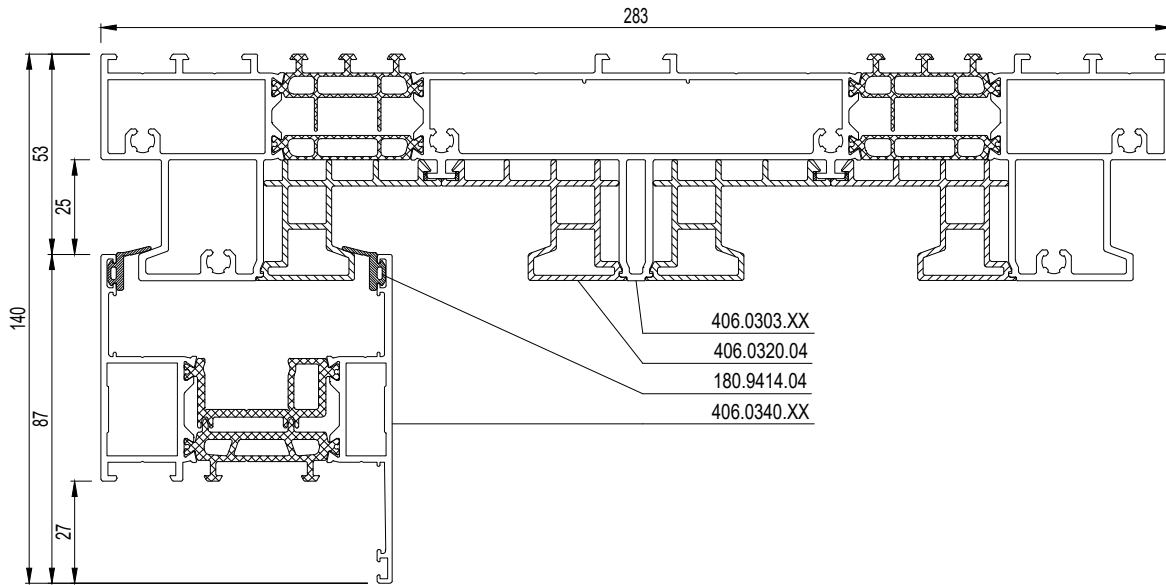
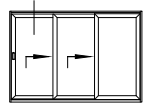

**S3LS 6**

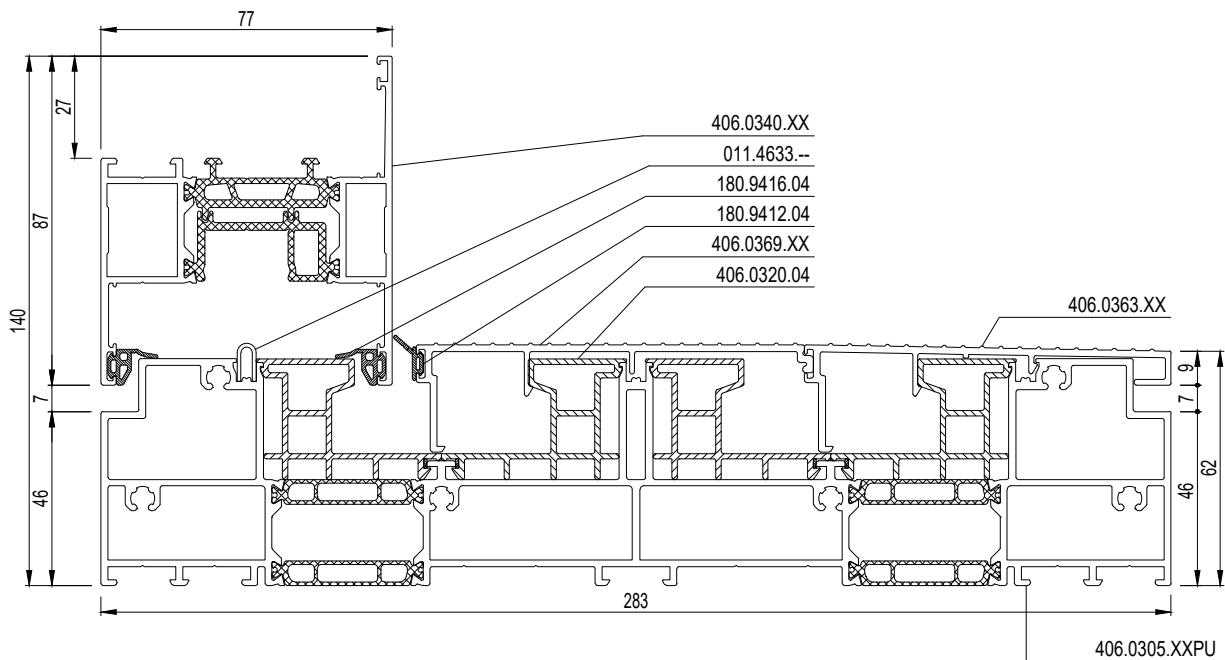
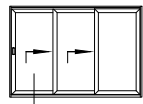

schaal - échelle  
 scale - Maßstab  
 1/2

**S3LS 5**

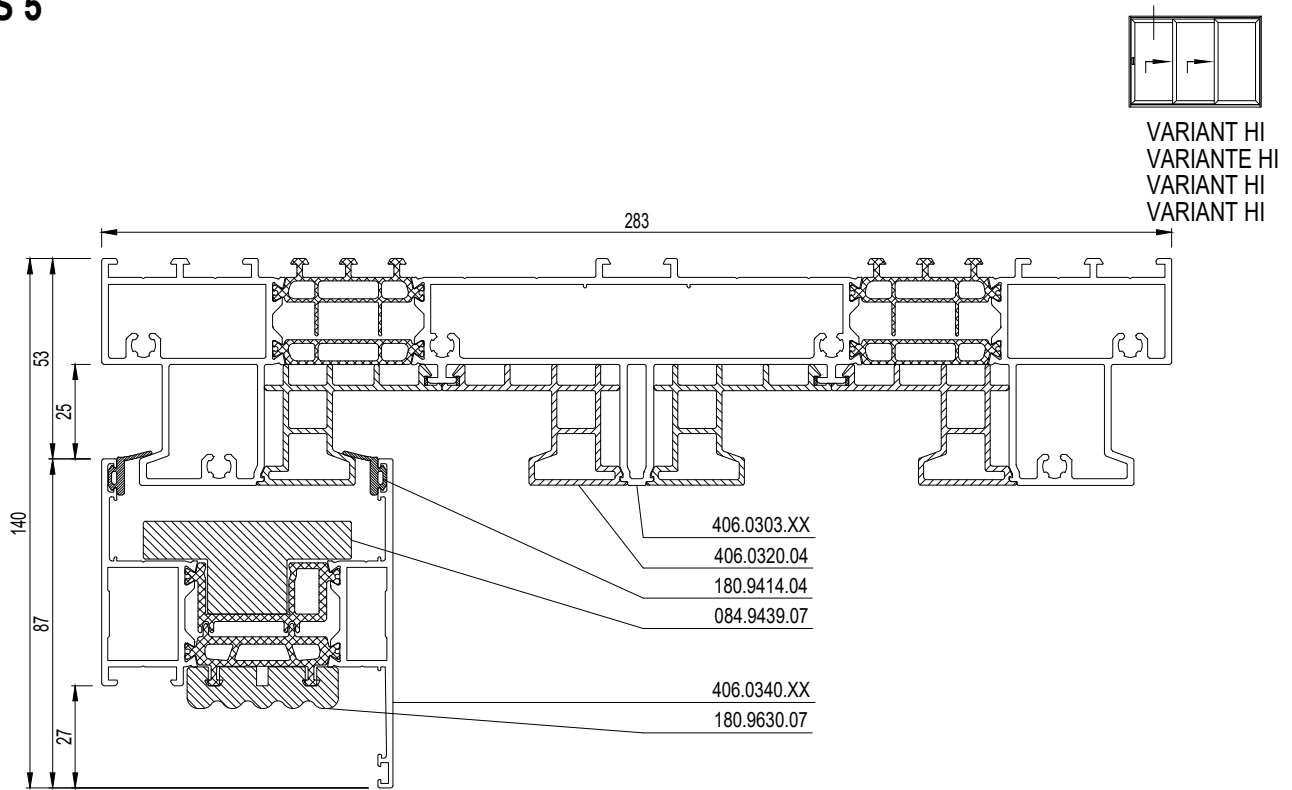

**S3LS 6**

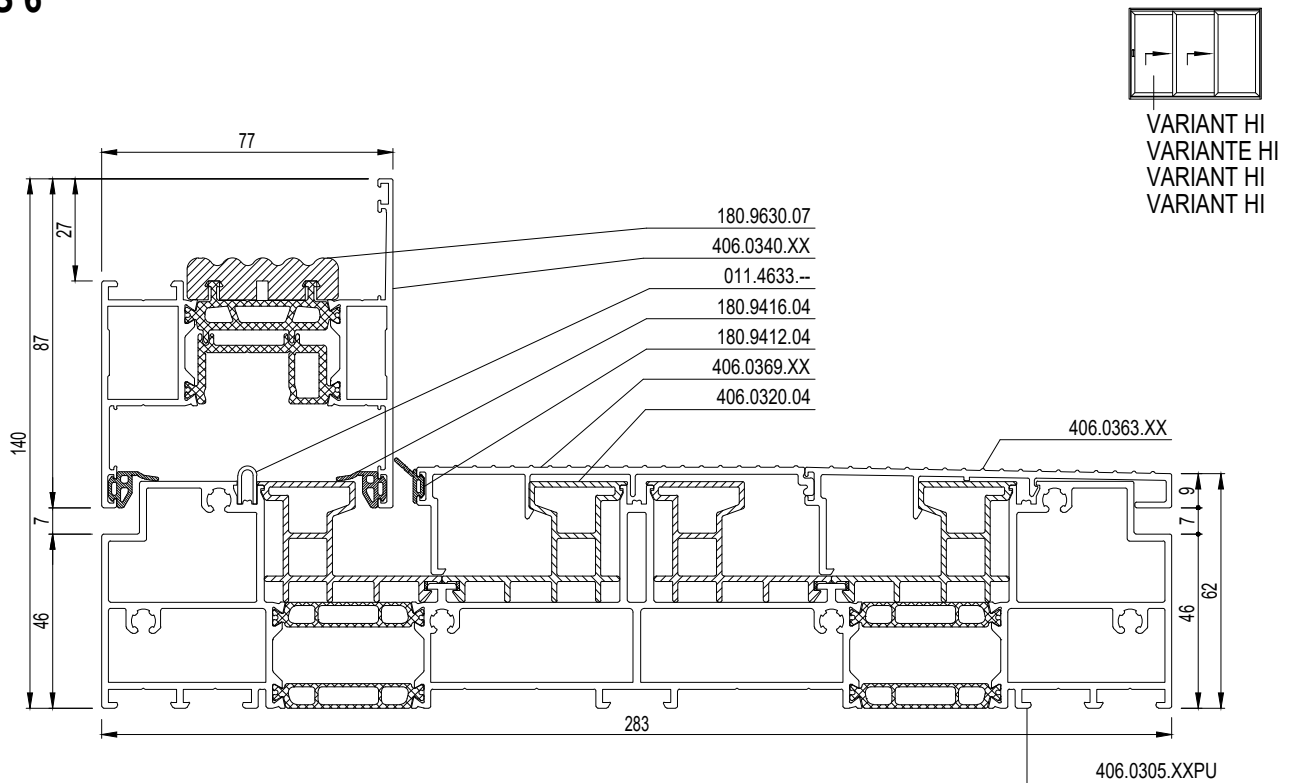

schaal - échelle  
 scale - Maßstab  
 1/2

**S3LS 7**

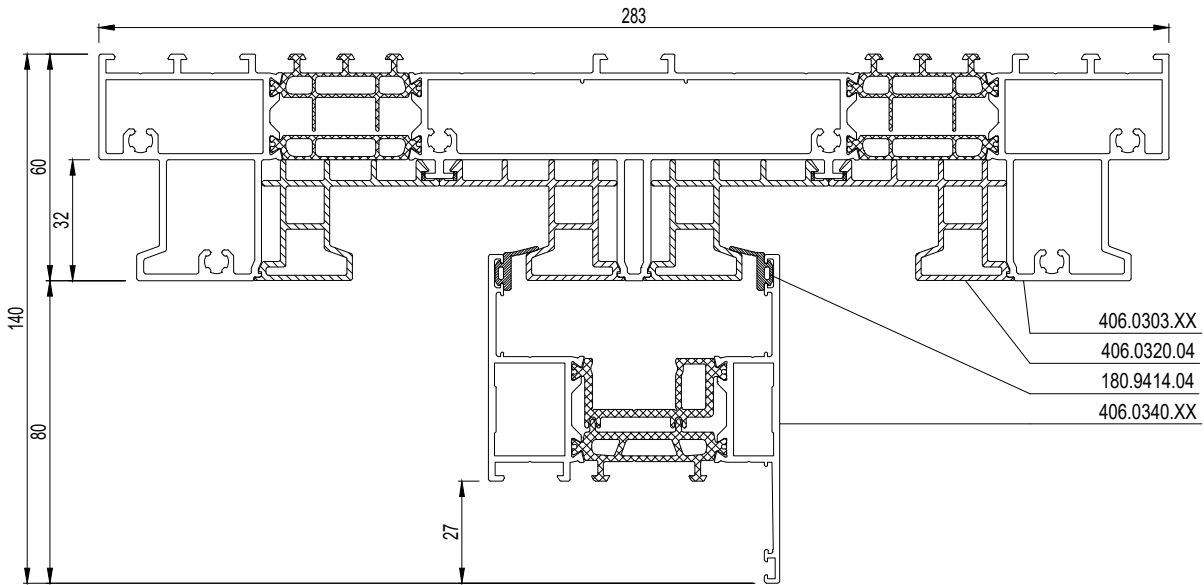
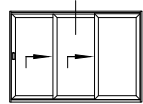

**S3LS 8**

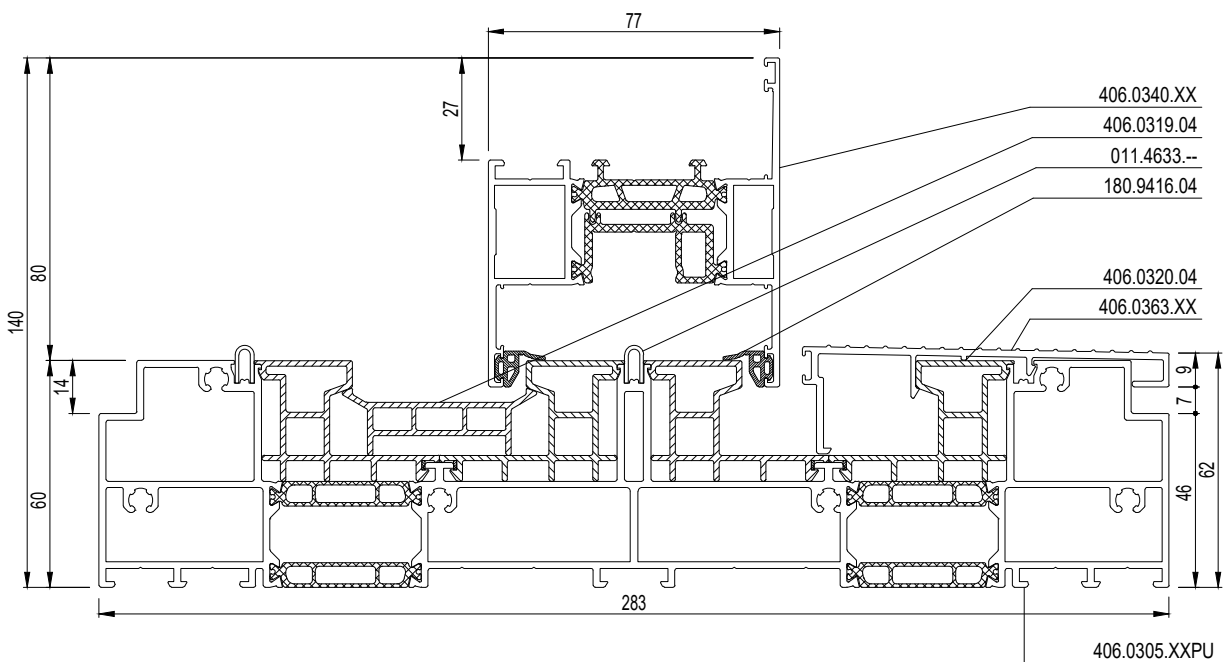
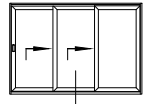

schaal - échelle  
 scale - Maßstab  
 1/2

## S3LS 7

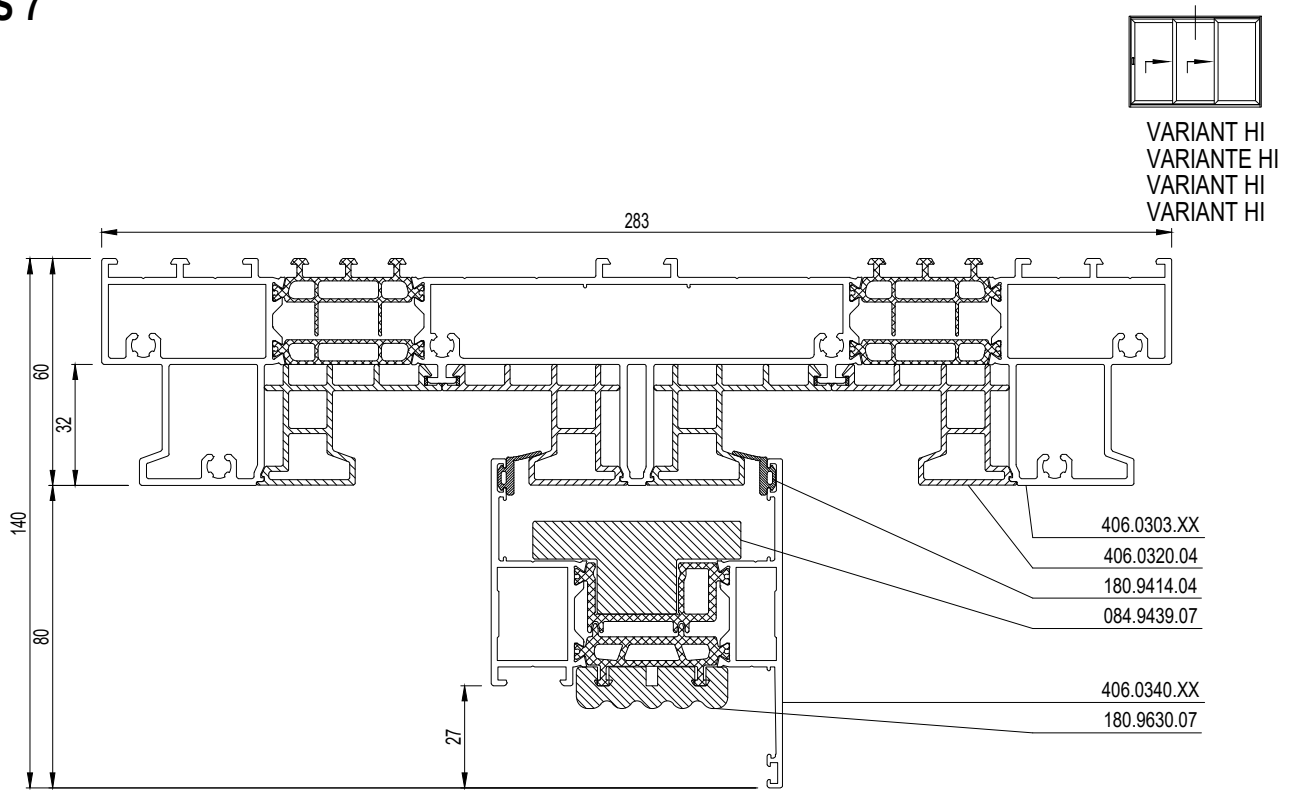

## S3LS 8

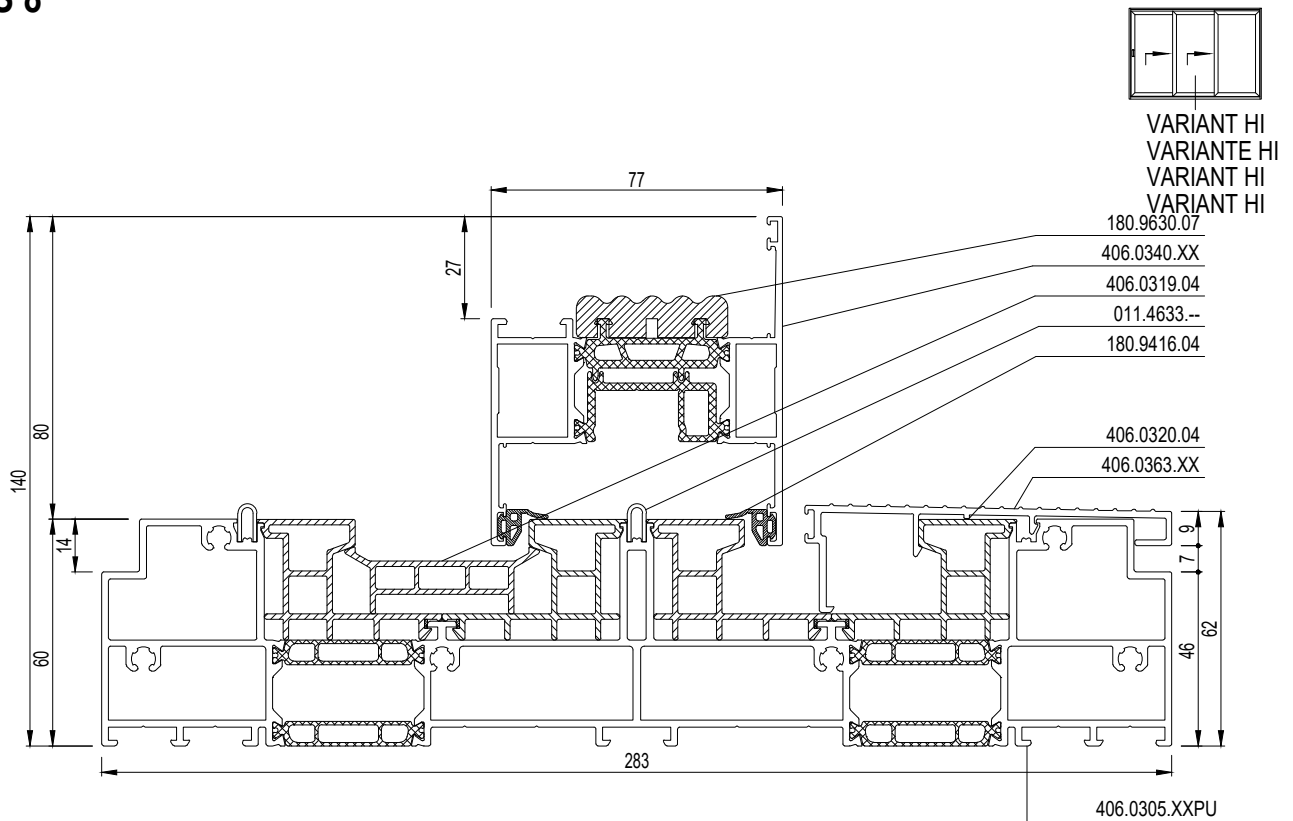

schaal - échelle  
 scale - Maßstab  
 1/2

**S3LS 9**

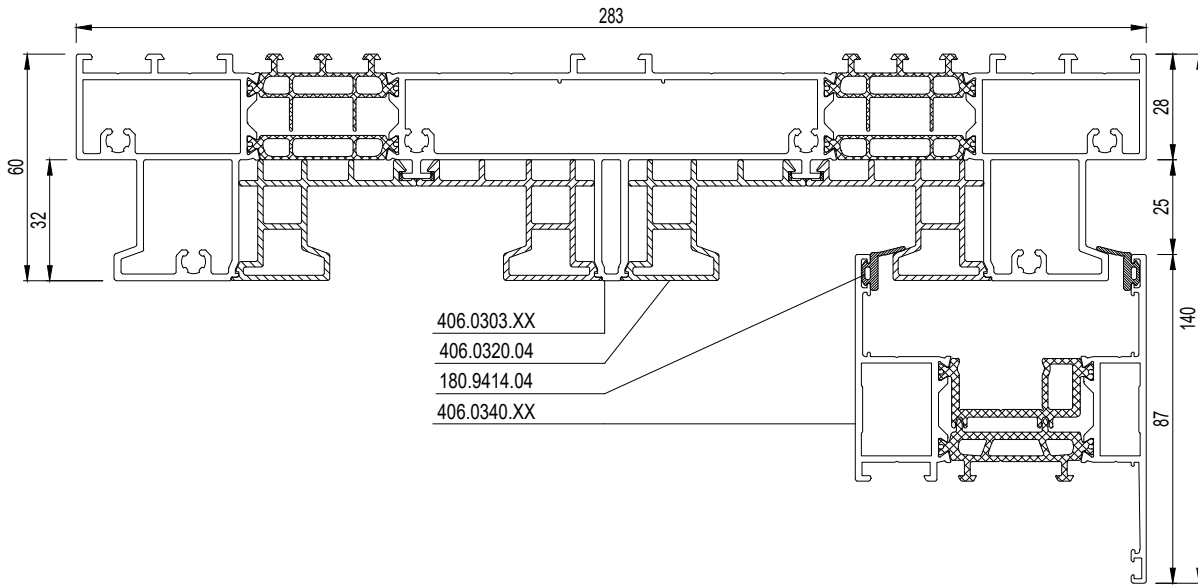
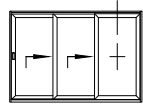

**S3LS 10**

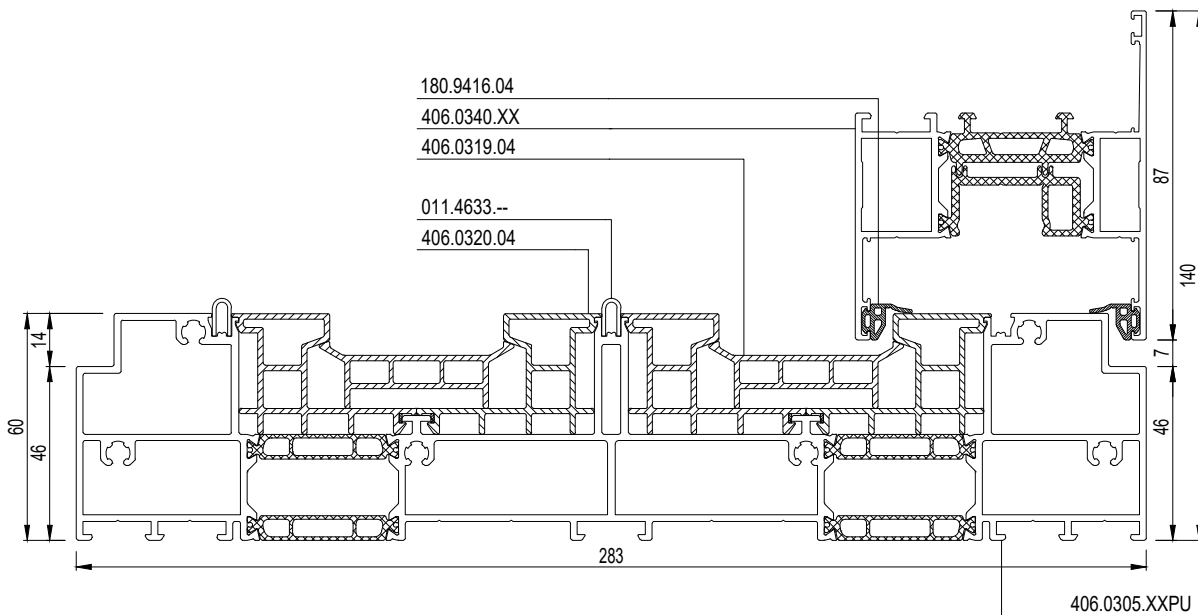
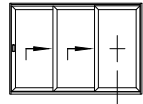

schaal - échelle  
 scale - Maßstab  
 1/2

**S3LS 9**

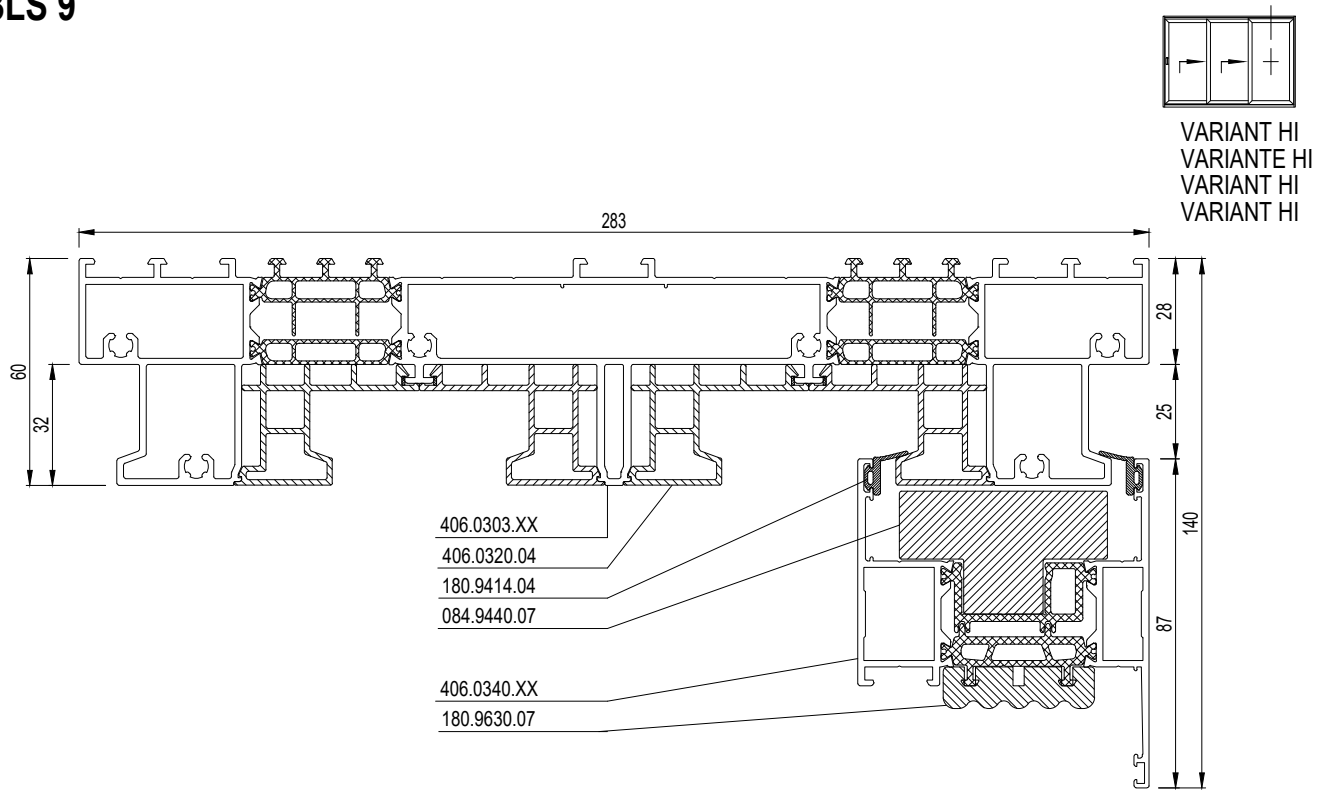

**S3LS 10**

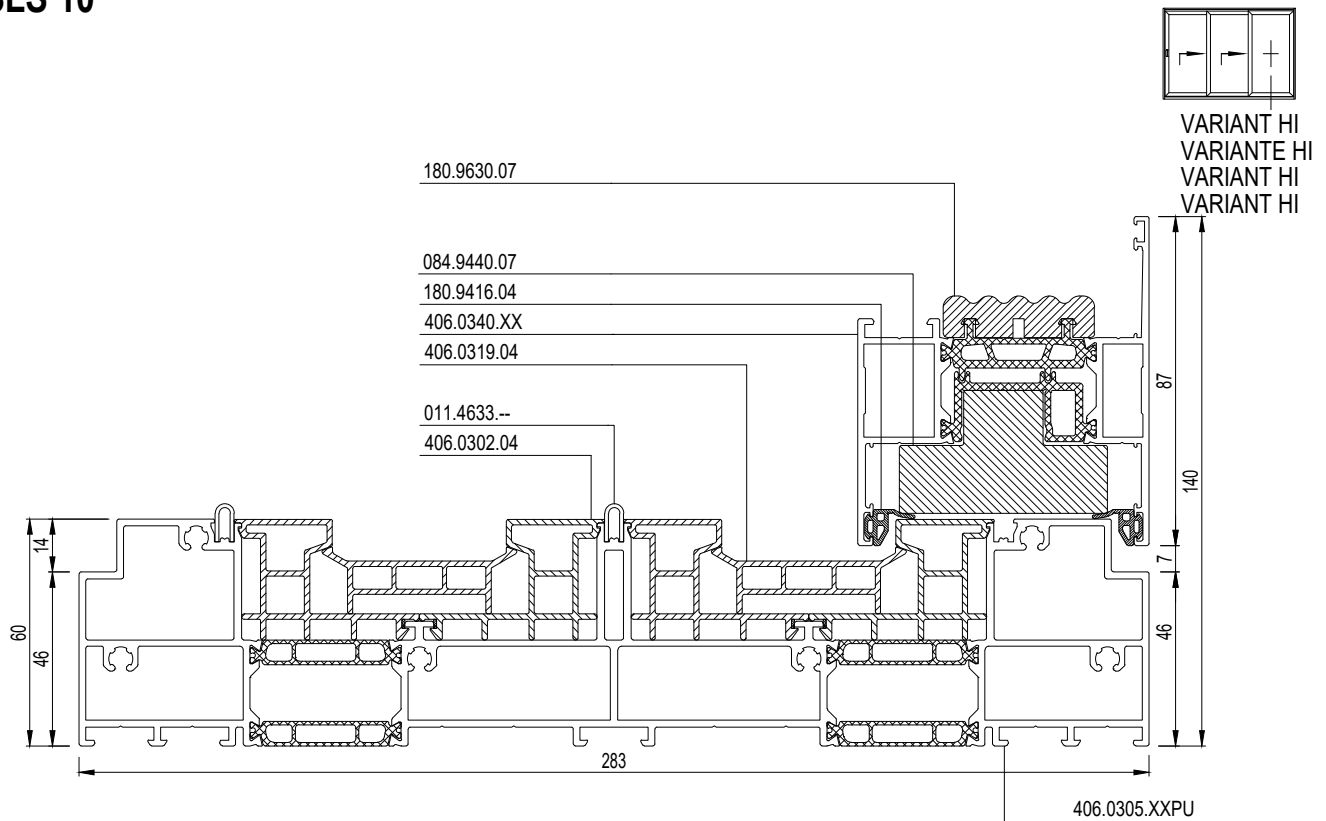

schaal - échelle  
 scale - Maßstab  
 1/2

**S3LS 15**

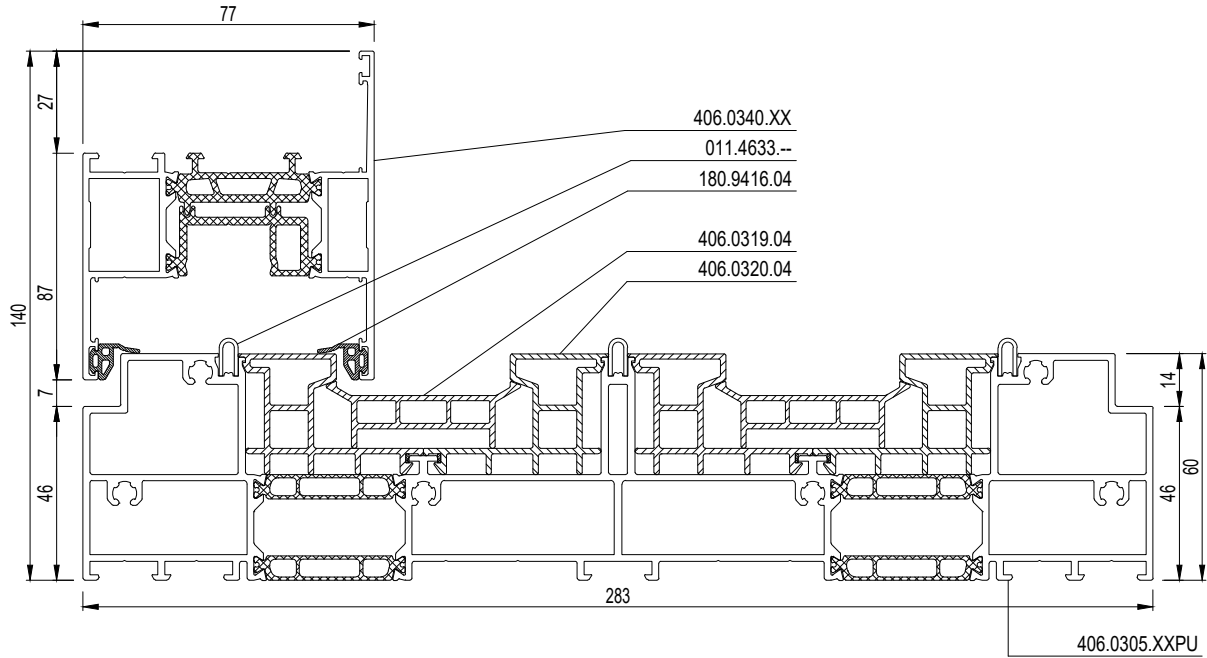
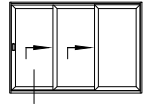

**S3LS 16**

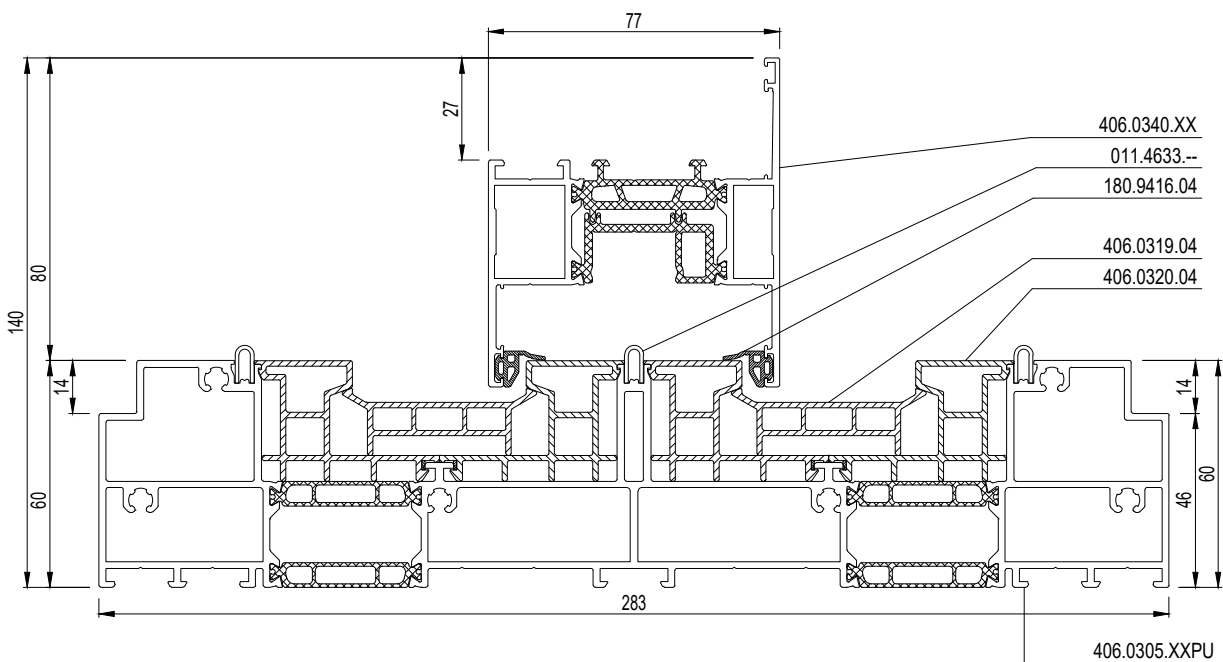
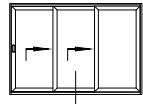

schaal - échelle  
 scale - Maßstab  
 1/2

**S3LS 15**

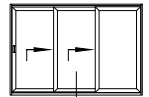

VARIANT HI  
 VARIANTE HI  
 VARIANT HI  
 VARIANT HI

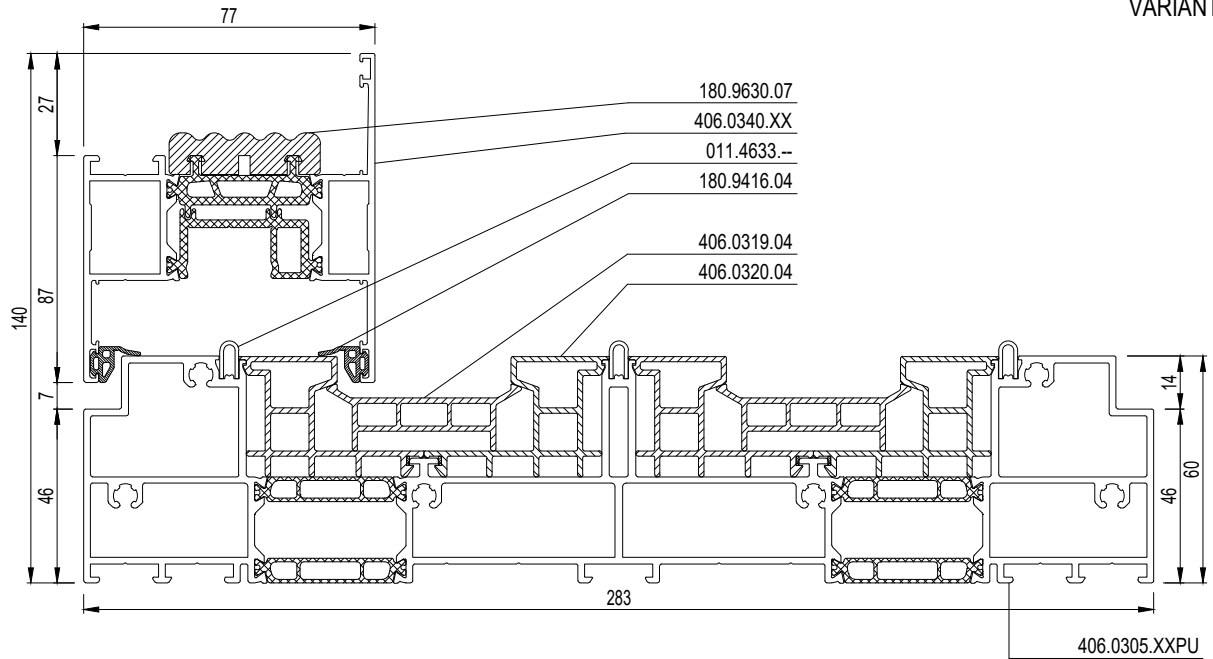

**S3LS 16**

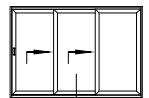

VARIANT HI  
 VARIANTE HI  
 VARIANT HI  
 VARIANT HI

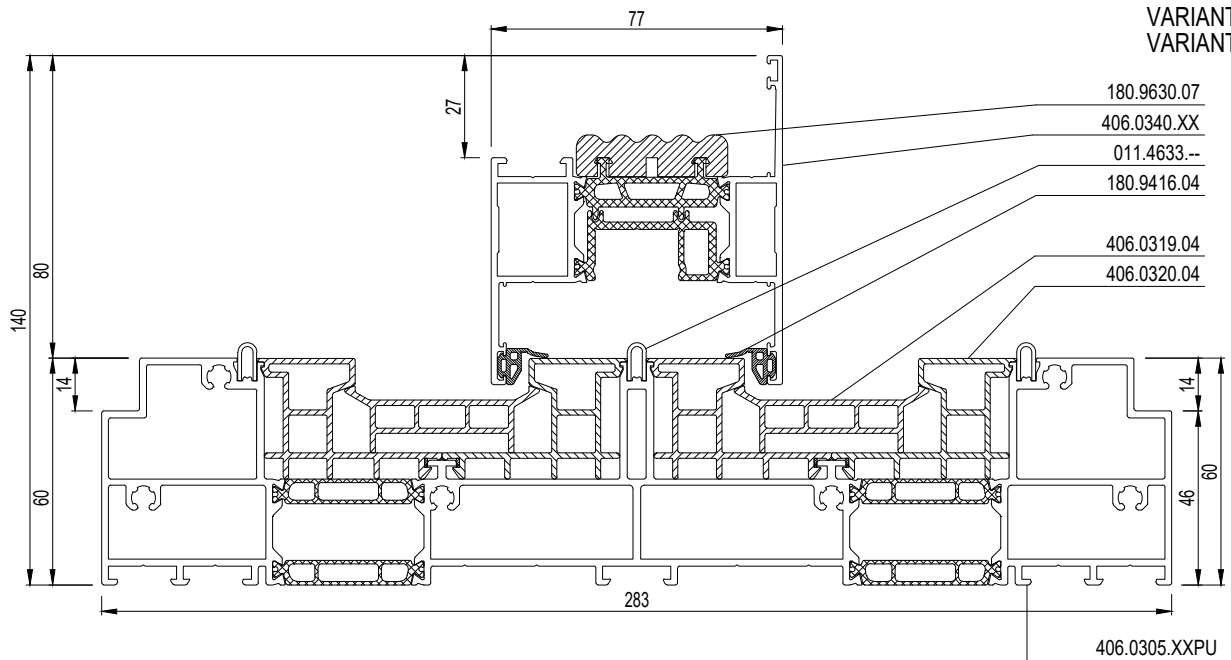

schaal - échelle  
 scale - Maßstab  
 1/2

**S3LS 17**

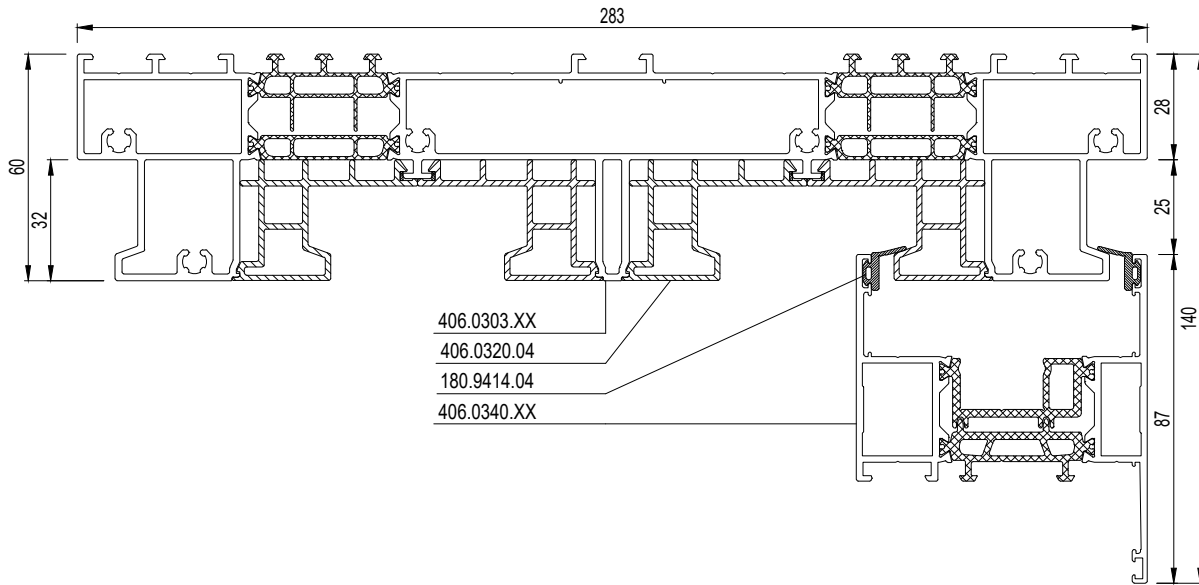
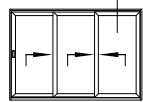

**S3LS 18**

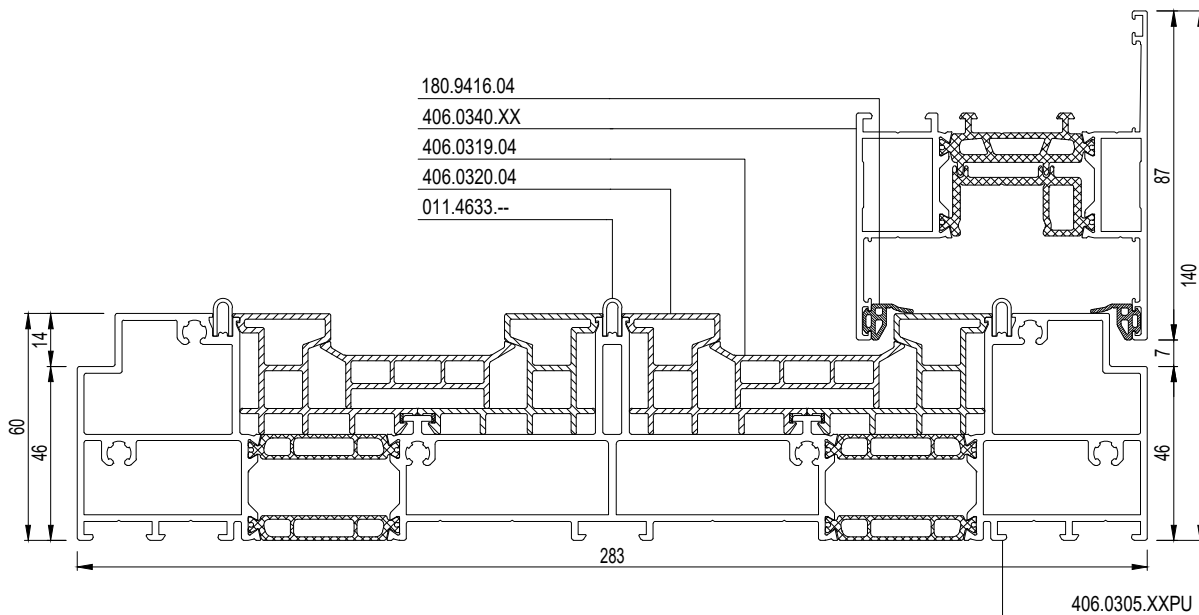
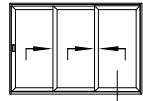

schaal - échelle  
 scale - Maßstab  
 1/2

**S3LS 17**

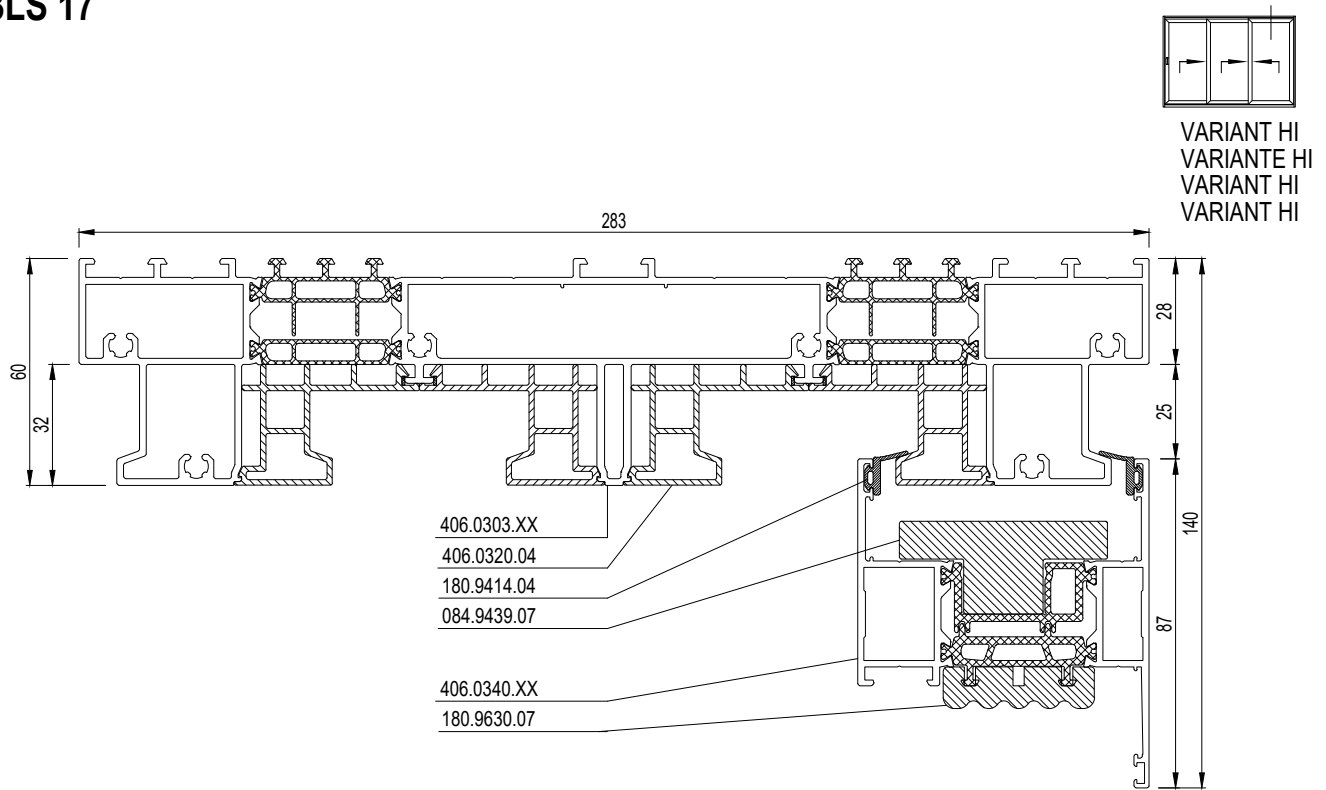

**S3LS 18**

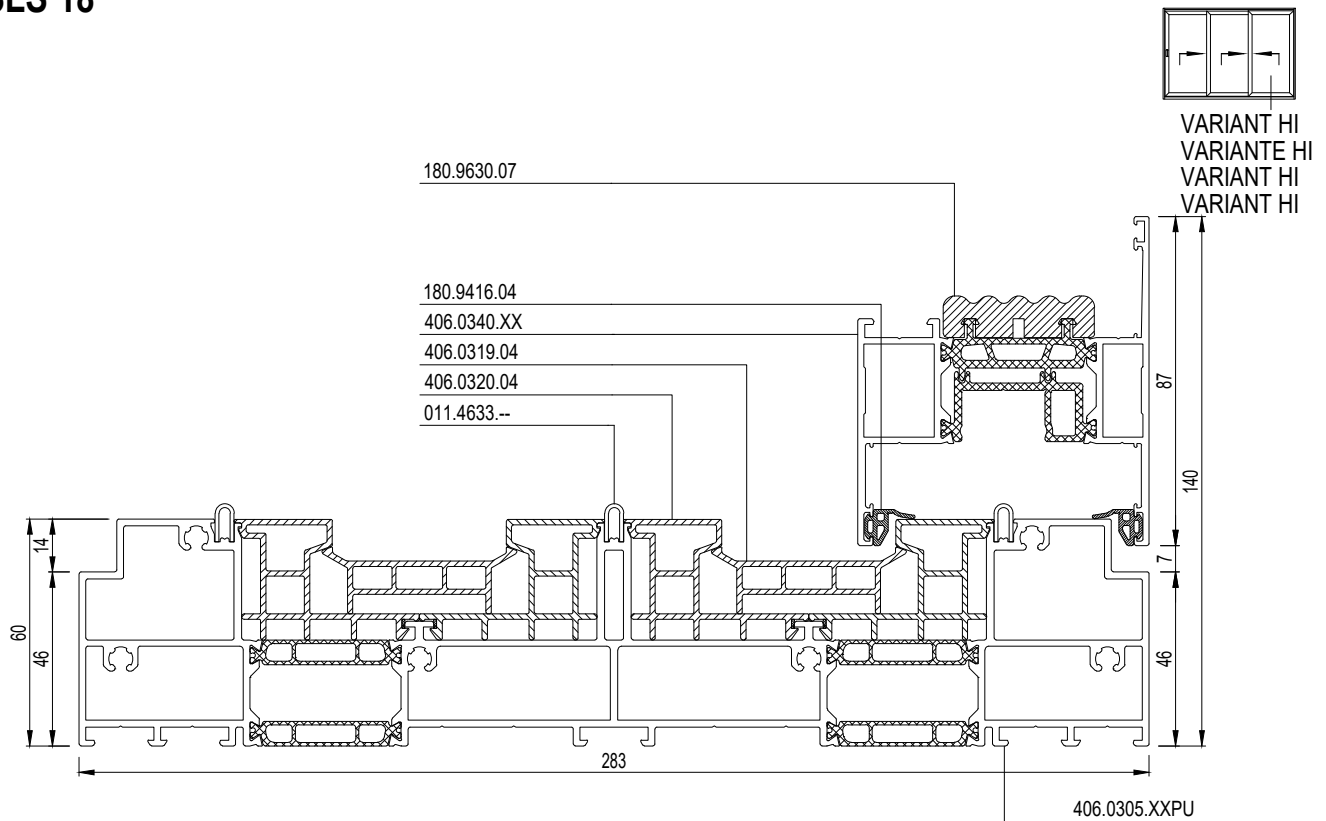

schaal - échelle  
 scale - Maßstab  
 1/2

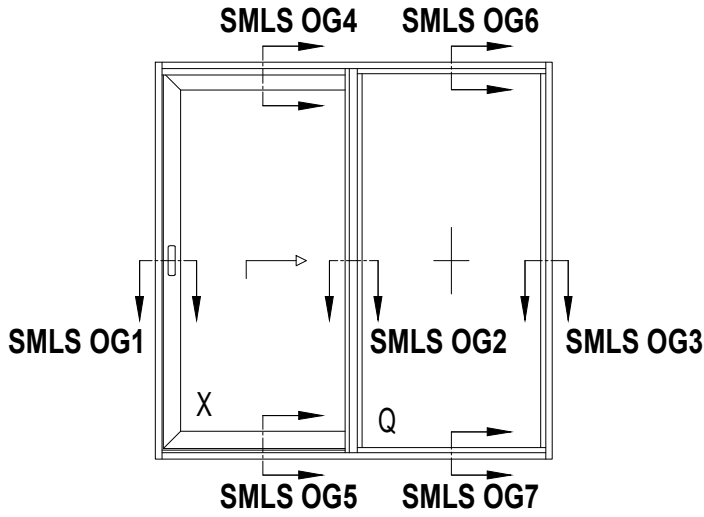

**SMLS OG1**

**SMLS OG2**

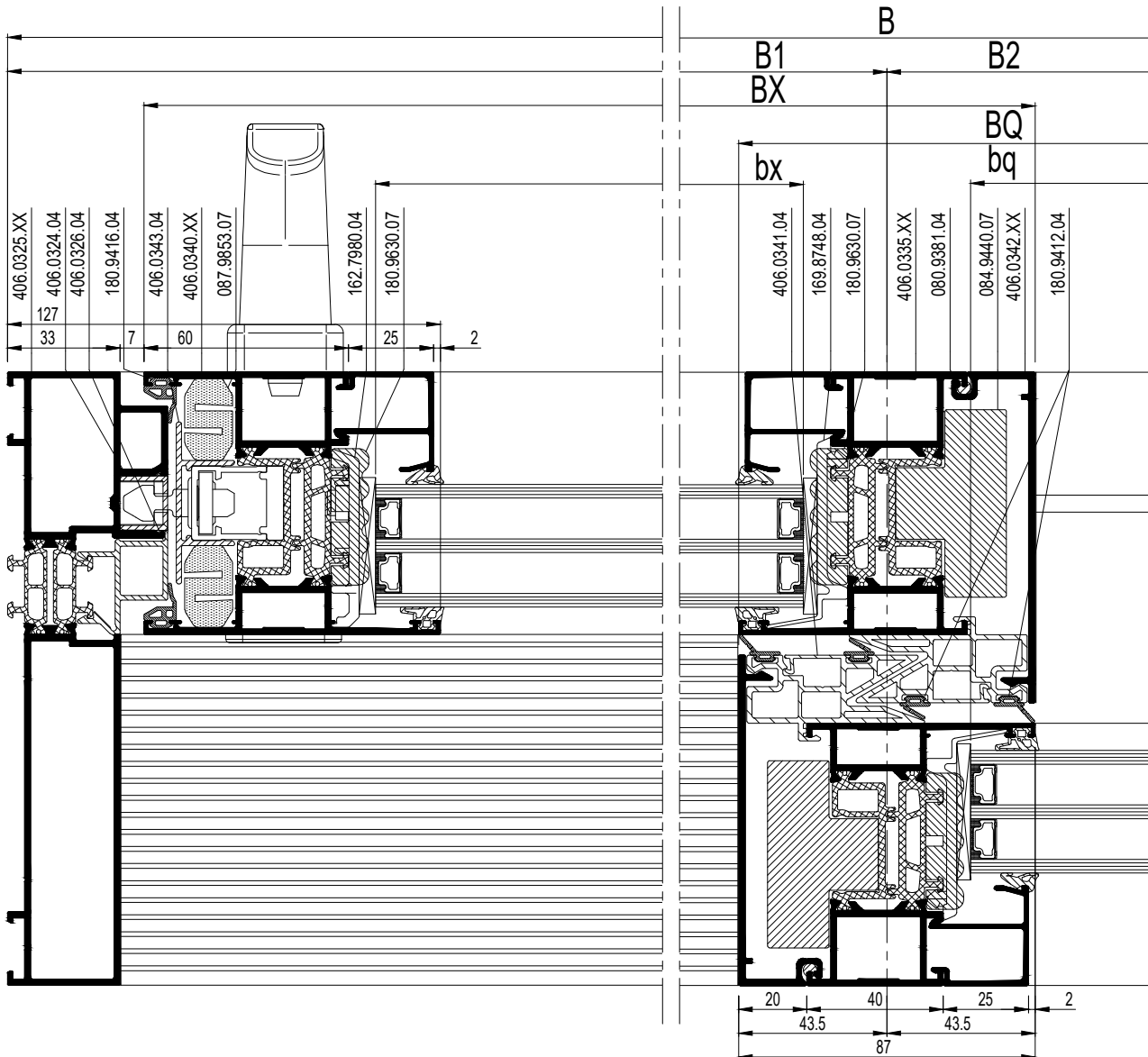

schaal - échelle  
 scale - Maßstab  
 1/2

## SMLS OG3

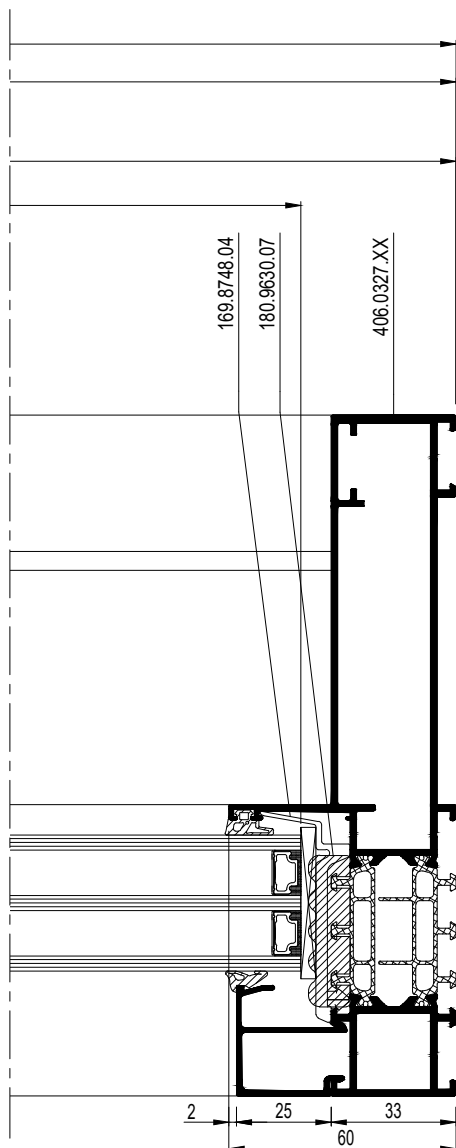

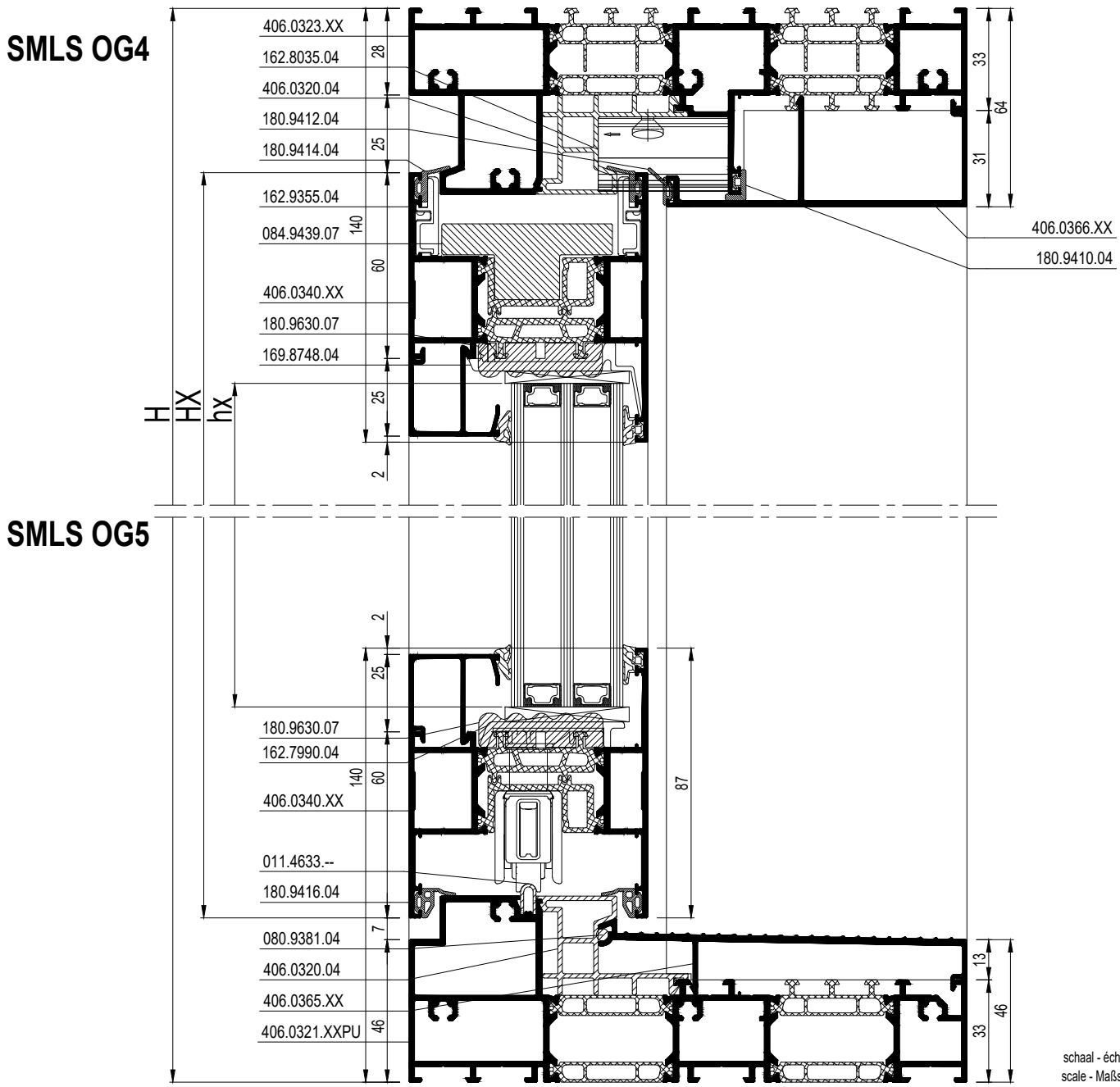
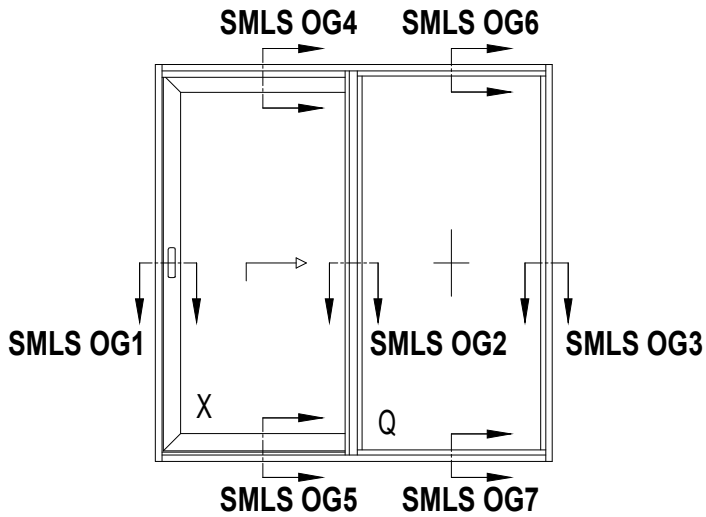

schaal - échelle  
 scale - Maßstab  
 1/2

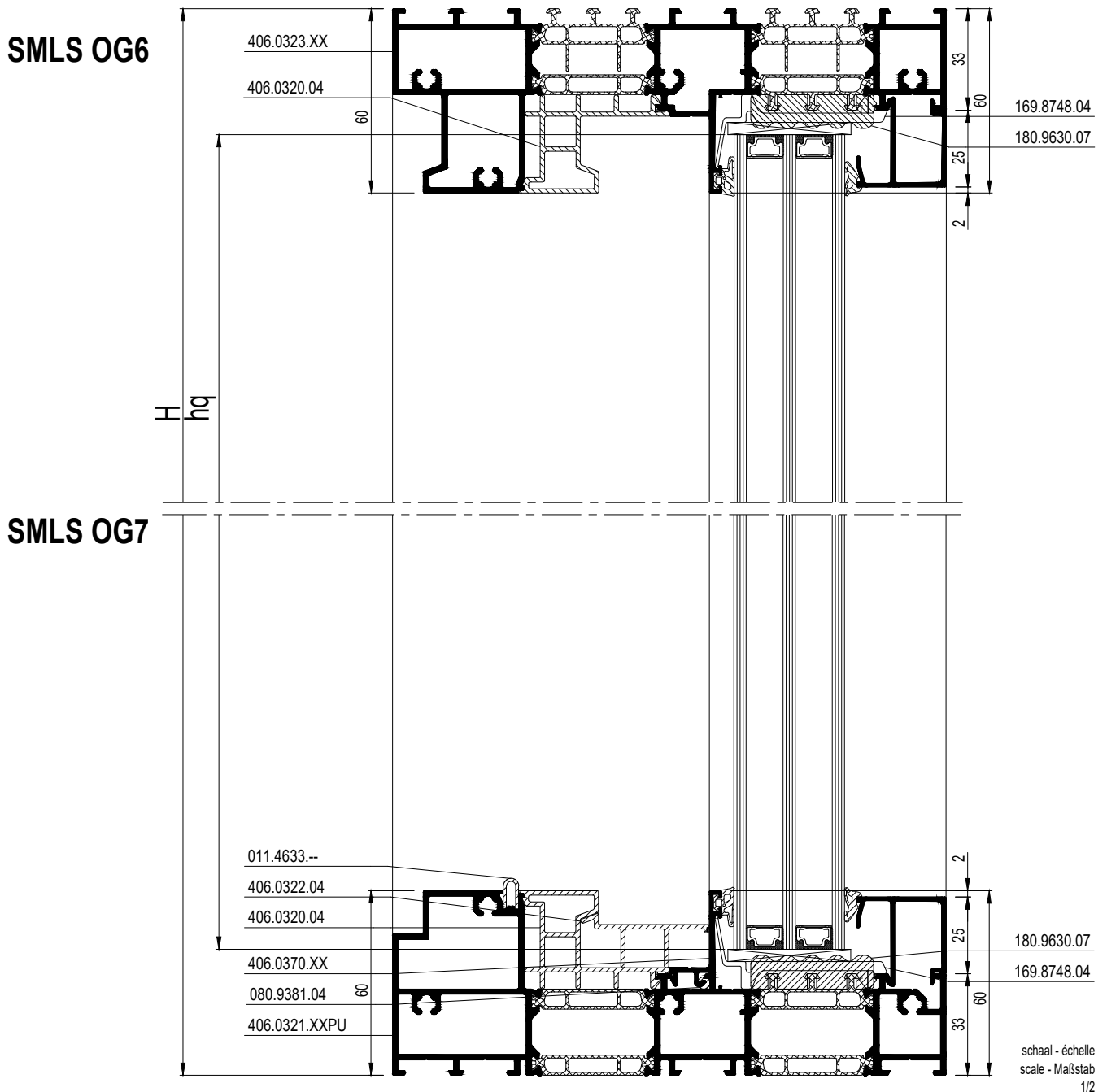

			#	$\leftarrow L_m$
406.0321.XXPU			1	B-66
406.0323.XX			1	B-66
406.0325.XX			1	H
406.0327.XX			1	H
406.0322.04			1	B2 - 73.5
406.0320.04			2	B - 66
011.4633.--			1	B - 80
406.0326.04			1	H - 120
406.0324.04			1	H - 120 *
406.0370.XX			1	B2 + 7.5
406.0365.XX			1	B1 - 77
406.0366.XX			1	B1 - 77
406.0340.XX			1	H - 106
			1	B1 + 3.5 (-20)
			1	B1 + 3.5 (-20)
406.0343.04			1	H - 176
030.3613.XX			2	H - 276
			2	B1 - 116.5
			2	H - 116
			2	B2 - 49.5
406.0335.XX			1	H - 146
			1	H - 66
406.0341.04			2	H - 106
406.0342.XX			1	H - 154
			1	H - 66
OM0.1505.00			1	34G.F

	BX = B1+3.5
	BQ = B2+43.5
	HX = H-106
	bx = BX-136
	bq = BQ-109
	hx = HX-136
	hq = H-82

		#
052.5371.--		16
168.8688.04		4
168.8932.00		2
168.8748.00		2
168.5012.--		2
168.8675.04		2
168.8105.00		4
168.5012.--		4
168.8106.00		4
050.5091.--		8
160.8725.--		4
160.8750.--		8
052.5300.--		2 x (H / 300)
162.7980.04		5
162.7990.04		3
169.8748.04		12
162.9355.04		6
080.9124.SY		2B + 4H
080.9381.04		B + 2H
180.9114.SY		2B + 4H
080.9738.04		2
084.9440.07		H - 159
		H - 66
084.9439.07		B1 - 65
087.9853.07		2 x (H - 160)
180.9630.07		2B + 4H
Lock set		1
Wheels set		1
162.7930.--		min. 1
162.8035.04		1
052.5309.--		2
162.9060.SY		1
162.9061.04		1
162.8081.04		2
162.8064.04		1
162.9310.04		2
180.9160.04		B
180.9410.04		B1
180.9412.04		B1 + 4H
180.9414.04		2B1
180.9416.04		2B1 + 2H
180.9493.04		1
062.7715.XX		34G.F
069.6830.04		34G.F

\* KNIP IN STUKKEN  
 \* COUPE EN MORCEAUX  
 \* CUT IN PIECES  
 \* IN STUCKE SCHNEIDEN



E

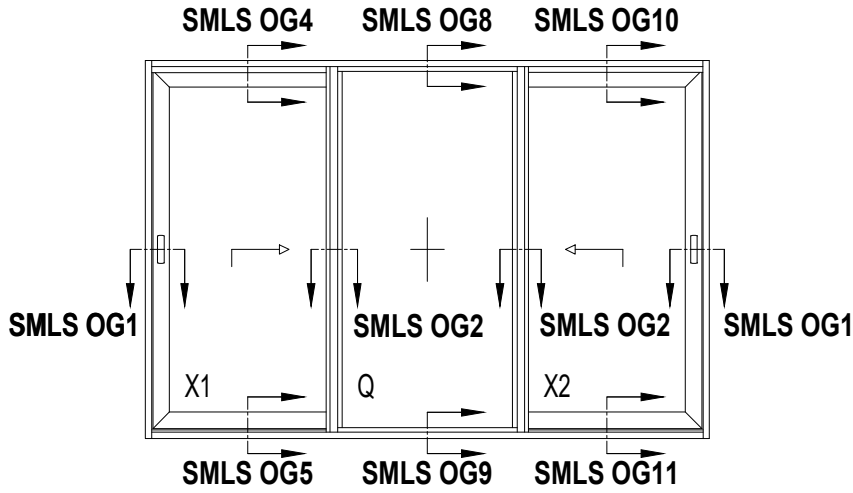

**SMLS OG8**

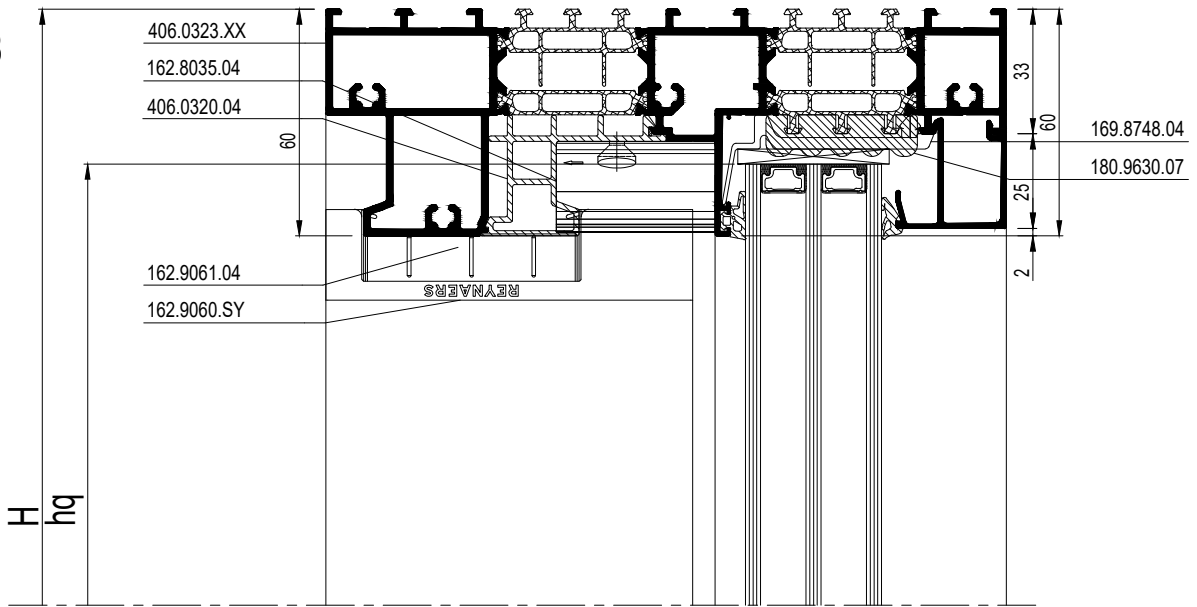

**SMLS OG9**

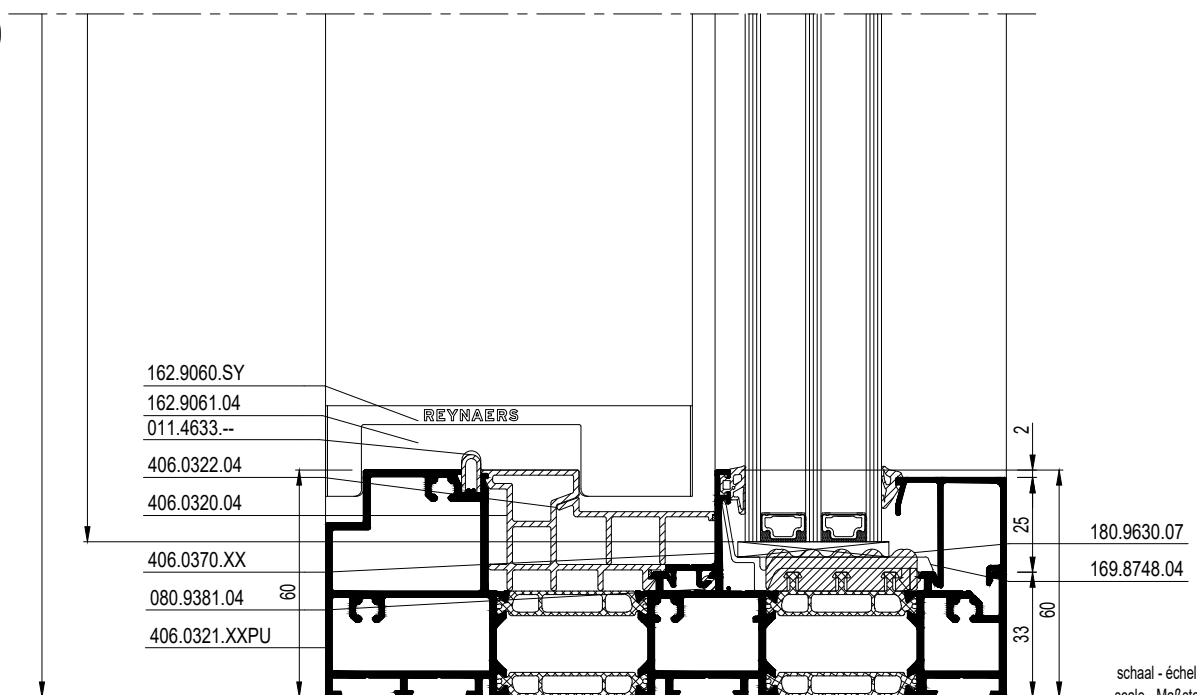

schaal - échelle  
 scale - Maßstab  
 1/2

**SMLS OG10**

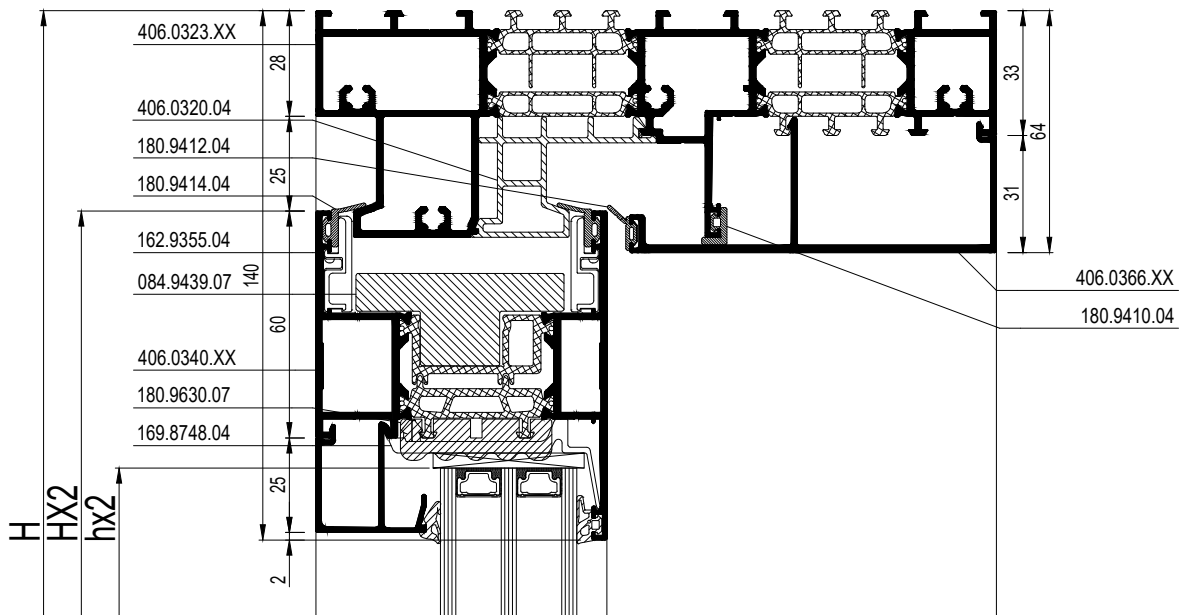

**SMLS OG11**

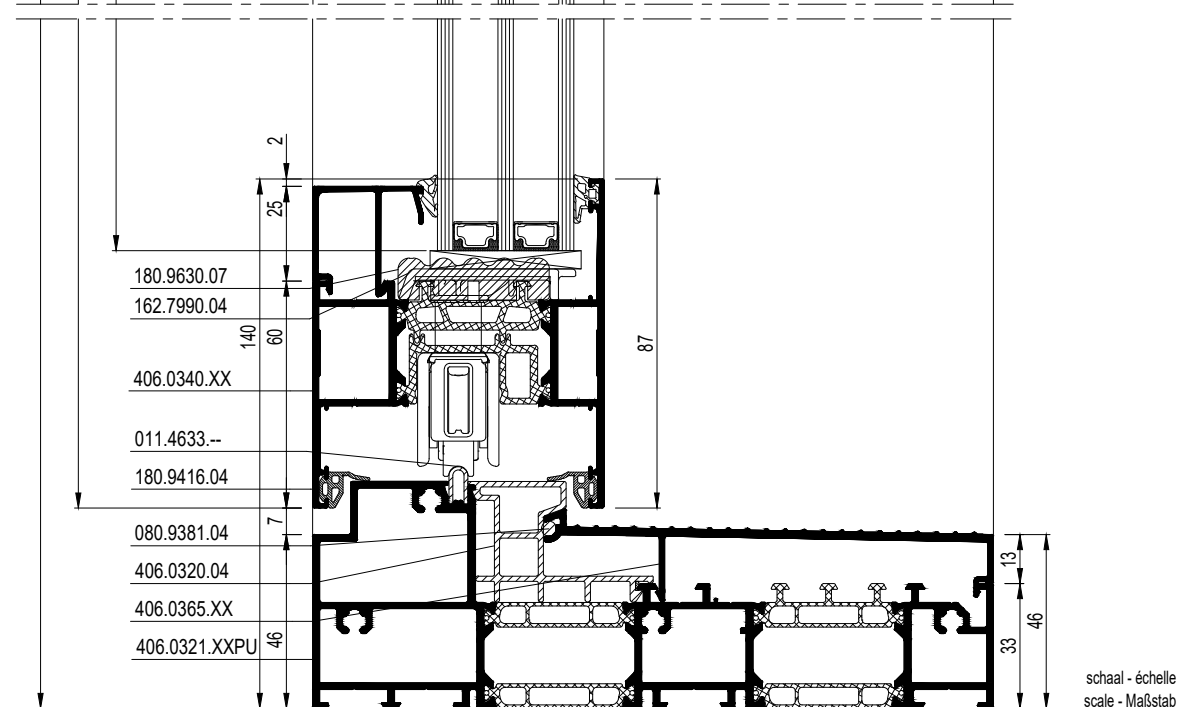

schaal - échelle  
 scale - Maßstab  
 1/2

			#	$\leftarrow L_m \rightarrow$
406.0321.XXPU			1	B-66
406.0323.XX			1	B-66
406.0325.XX			2	H
406.0322.XX			1	B2 - 81
406.0320.04			2	B - 66
011.4633.--			1	B - 94
406.0326.04			2	H - 120
406.0324.04			2	H - 120 *
406.0370.XX			1	B2 + 81
406.0365.XX			1	B1 - 77
			1	B3 - 77
406.0366.XX			1	B1 - 77
			1	B3 - 77
406.0340.XX			2	H - 106
			2	B1 + 3.5 (-20)
			2	B3 + 3.5 (-20)
406.0343.04			2	H - 176
030.3613.XX			4	H - 276
			2	B1 - 116.5
			2	H - 116
			2	B2 - 33
			2	B3 - 116.5
406.0335.XX			2	H-146
			2	H-66
406.0341.04			4	H - 106
406.0342.XX			2	H-154
			2	H-66
0M0.1505.00			2	34G.F

	BX1 = B1+3.5
	BQ = B2+87
	BX2 = B3+3.5
	HX = H-106
	bx1 = BX1-136
	bq = BQ-136
	bx3 = BX3-136
	hx = HX-136
	hq = H-82

		#
052.5371.--		16
168.8932.00		4
168.8748.00		4
168.5012.--		4
168.8688.04		4
168.8105.00		8
168.5012.--		8
168.8106.00		8
050.5091.--		16
160.8725.--		8
160.8750.--		12
052.5300.--		4 x (H / 300)
162.7980.04		10
162.7990.04		5
169.8748.04		16
162.9355.04		12
080.9124.SY		2B + 6H
080.9381.04		B + 4H
180.9114.SY		2B + 6H
080.9738.04		2
084.9440.07		2 x (H - 159) 2 x (H - 66)
084.9439.07		B1 - 65 B3 - 65
087.9853.07		4 x (H - 160)
180.9630.07		2B + 6H
Lock set		2
Wheels set		2
162.7930.--		min. 2
162.8035.04		2
052.5309.--		4
162.9060.SY		2
162.9061.04		2
162.8081.04		4
162.8064.04		1
162.8065.04		1
162.9310.04		2
180.9160.04		B
180.9410.04		B1 + B3
180.9412.04		B1 + B3 + 8H
180.9414.04		2B1 + 2B3
180.9416.04		2B1+2B3+4H
180.9493.04		2
062.7715.XX		34G.F
069.6830.04		34G.F

\* KNIP IN STUKKEN  
 \* COUPE EN MORCEAUX  
 \* CUT IN PIECES  
 \* IN STÜCKE SCHNEIDEN



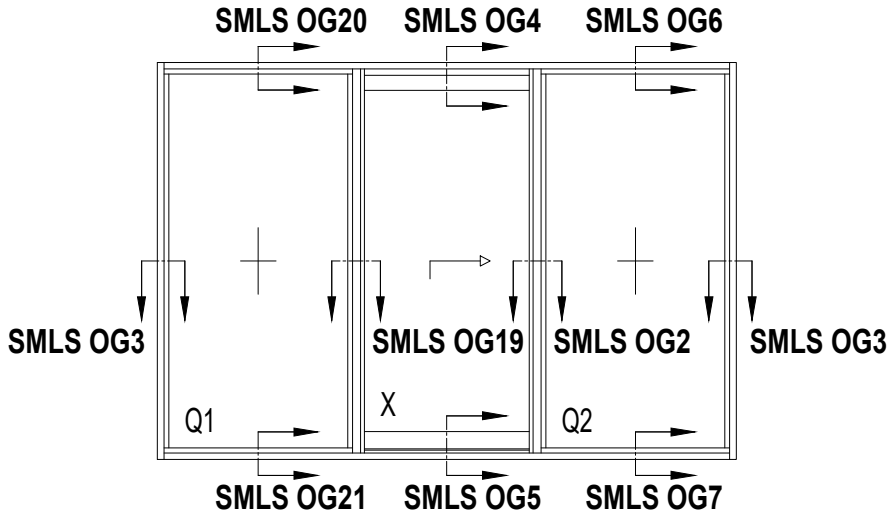

**SMLS OG19**

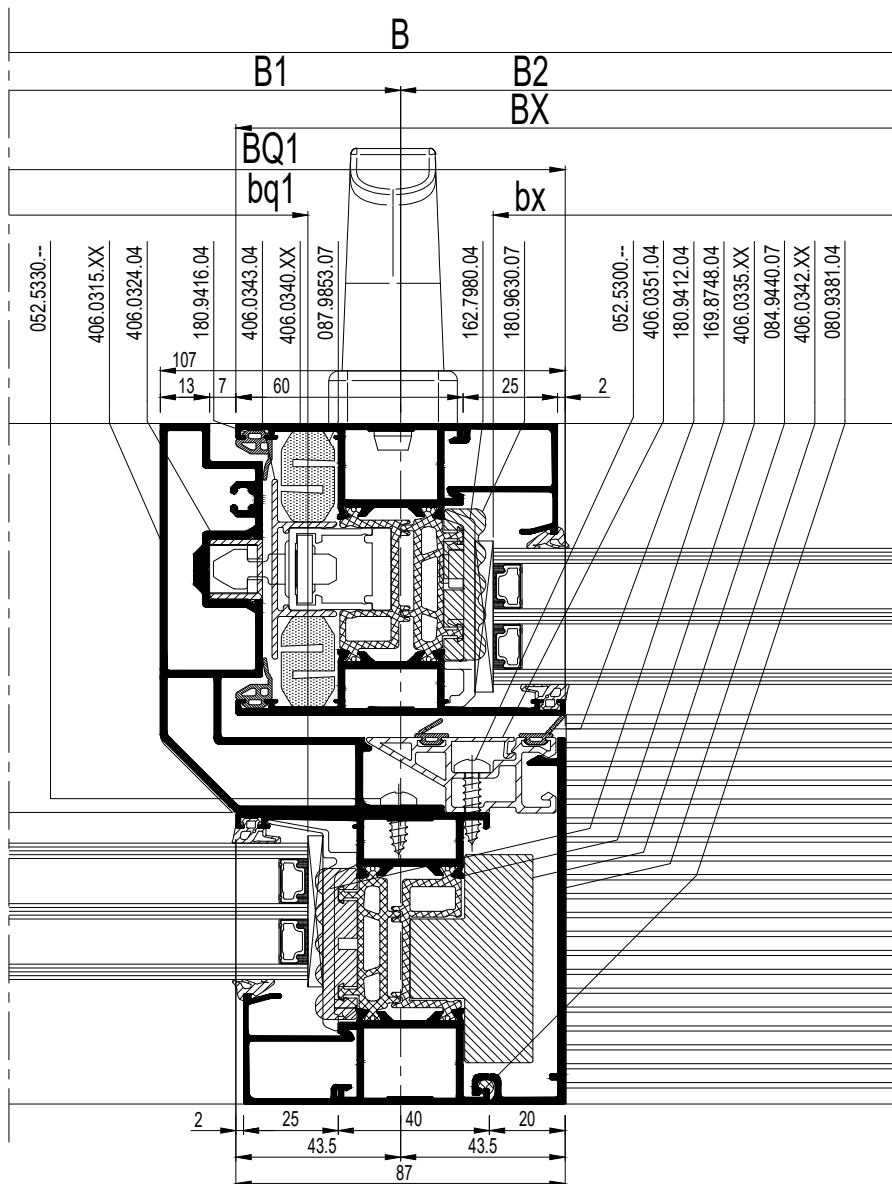

schaal - échelle  
 scale - Maßstab  
 1/2

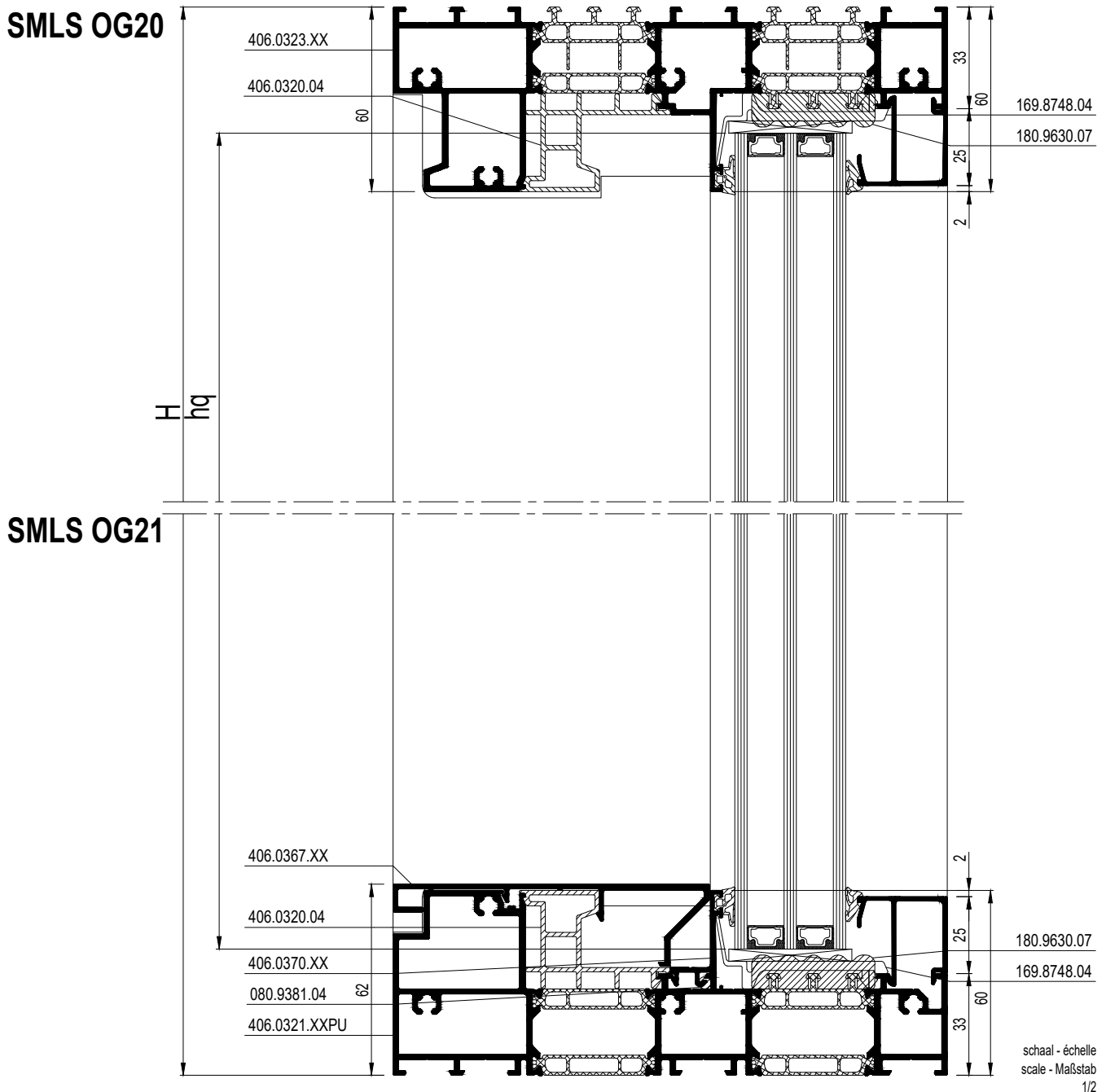







			#	$\leftarrow L_m$
406.0321.XXPU			1	B-66
406.0323.XX			1	B-66
406.0327.XX			2	H
406.0322.04			1	B3 - 73.5
406.0320.04			2	B - 66
011.4633.--			1	B2 + B3 + 3.5
406.0324.04			1	H - 120 *
406.0370.XX			1	B1 + 7.5
			1	B3 + 7.5
406.0365.XX			1	B2 - 87.5
406.0366.XX			1	B2 - 87.5
406.0340.XX			1	H - 106
			1	B2 + 87 (-20)
			1	B2 + 87 (-20)
406.0343.04			1	H - 176
030.3613.XX			2	B1 - 49.5
			2	B2 - 33
			2	B3 - 49.5
			2	H - 276
			4	H - 116
406.0335.XX			1	H - 146
			2	H - 66
406.0341.04			2	H - 106
406.0342.XX			1	H - 154
			2	H - 66
0M0.1505.00			1	34G.F
406.0351.04			1	H - 106
406.0315.XX			1	H - 65.5
406.0367.XX			1	B1 - 77.5

	BQ1 = B1+43.5
	BX = B2+87
	BQ2 = B3+43.5
	HX = H-106
	bq1 = BQ1-109
	bx = BX-136
	bq2 = BQ2-109
	hx = HX-136
	hq = HQ-82

		#
052.5371.--		16
168.8688.04		8
168.8932.00		4
168.8748.00		4
168.5012.--		4
168.8675.04		4
168.8105.00		4
168.5012.--		4
168.8106.00		4
050.5091.--		8
160.8725.--		4
160.8750.--		12
052.5300.--		3 x (H / 300)
162.7980.04		5
162.7990.04		3
169.8748.04		20
162.9355.04		6
080.9124.SY		2B + 6H
080.9381.04		B + 3H
180.9114.SY		2B + 6H
080.9738.04		2
084.9440.07		H - 159
		2x (H - 66)
084.9439.07		B2 + 18.5
087.9853.07		2 x (H - 160)
180.9630.07		2B + 6H
Lock set		1
Wheels set		1
162.7930.--		min. 1
162.8035.04		2
052.5309.--		4
162.9060.SY		1
162.9061.04		1
162.8064.04		1
162.8065.04		1
162.9310.04		2
180.9160.04		(B2+B3)
180.9410.04		B2
180.9412.04		B2 + 6H
180.9414.04		2B2
180.9416.04		2B2 + 2H
180.9493.04		1
062.7715.XX		34G.F
069.6830.04		34G.F

\* KNIP IN STUKKEN  
 \* COUPE EN MORCEAUX  
 \* CUT IN PIECES  
 \* IN STUCKE SCHNEIDEN





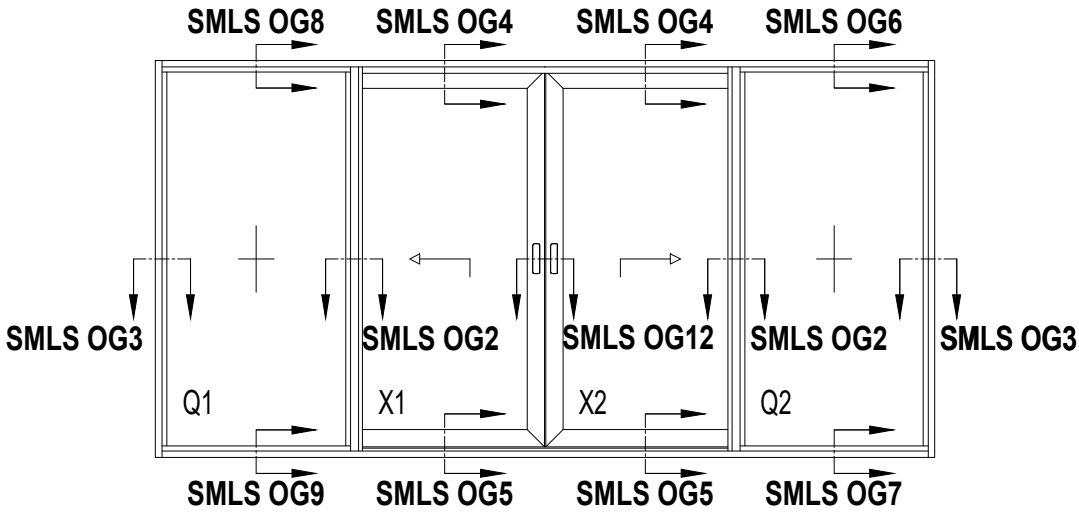



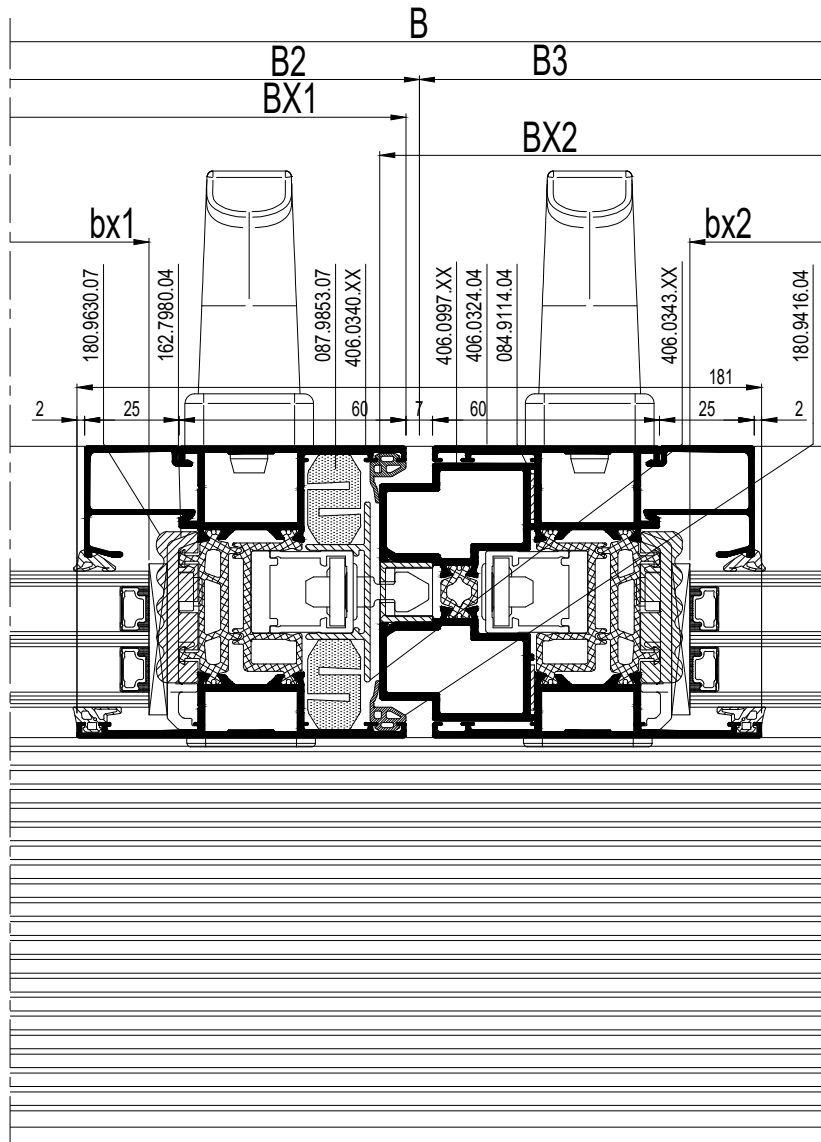





















































		#
162.8100.--		2
052.5360.--		2
052.5310.--		2
052.5330.--		H / 300





**SMLS OG12**





















			#	
406.0321.XXPU			1	B-66
406.0323.XX			1	B-66
406.0327.XX			2	H
406.0322.04			1	B1 - 73.5
			1	B4 - 73.5
406.0320.04			2	B - 66
011.4633.--			1	(B1+B2) - 9.5
			1	(B3+B4) - 89.5
406.0324.04			1	H - 188 *
406.0370.XX			1	B1 + 7.5
			1	B4 + 7.5
406.0365.XX			1	(B2+B3) - 87.5
406.0366.XX			1	(B2+B3) - 87.5
406.0340.XX			2	H - 106
			2	B2 + 40 (-20)
			2	B3 + 40 (-20)
406.0343.04			1	H - 176
030.3613.XX			4	H - 276
			2	B1 - 49.5
			4	H - 116
			2	B2 - 80
			2	B3 - 80
			2	B4 - 49.5
406.0335.XX			2	H-146
			2	H-66
406.0341.04			4	H - 106
406.0342.XX			2	H-154
			2	H-66
406.0997.XX			1	H - 192
OM0.1505.00			2	 34G.F

\* KNIP IN STUKKEN  
 \* COUPE EN MORCEAUX  
 \* CUT IN PIECES  
 \* IN STÜCKE SCHNEIDEN

\*\* VOOR SECUNDAIRE VLEUGEL  
 \*\* POUR SEMI-FIXE  
 \*\* FOR SECOND VENT  
 \*\* FÜR STANDFLÜGEL

BQ1 = B1+43.5
BX1 = B2+40
BX2 = B3+54
BQ2 = B4+43.5
HX = H-106
bq1 = BQ1-109
bx1 = BX1-136
bx2 = BX2-150
bq2 = BQ2-109
hq = H-82
hx = HX-136

		#
052.5371.--		16
168.8688.04		8
168.8932.00		4
168.8748.00		4
168.5012.--		4
168.8675.04		4
168.8105.00		8
168.5012.--		8
168.8106.00		8
050.5091.--		16
160.8725.--		8
160.8750.--		16
052.5300.--		4 x (H / 300)
050.5074.--		 34G.F
162.7980.04		10
162.7990.04		5
169.8748.04		24
162.9355.04		12
080.9124.SY		2B + 8H
080.9381.04		B + 4H
180.9114.SY		2B + 8H
084.9114.04		2H
080.9738.04		2
084.9440.07		2 x (H - 159) 2 x (H - 66)
084.9439.07		B2 - 28.5 B3 - 28.5
087.9853.07		2 x (H - 160)
180.9630.07		2B + 8H
Lock set		1
Lock set		1 **
Wheels set		2
162.7930.--		min. 1
162.7940.--		1
162.8035.04		2
052.5309.--		4
162.9060.SY		2
162.9061.04		2
162.8064.04		1
162.8065.04		1
162.9310.04		2
180.9160.04		B
180.9410.04		B2 + B3
180.9412.04		B2 + B3 + 8H
180.9414.04		2B2 + 2B3
180.9416.04		2B2+2B3+2H
180.8120.04		1
180.9493.04		1
069.6830.04		 34G.F
062.7715.XX		 34G.F

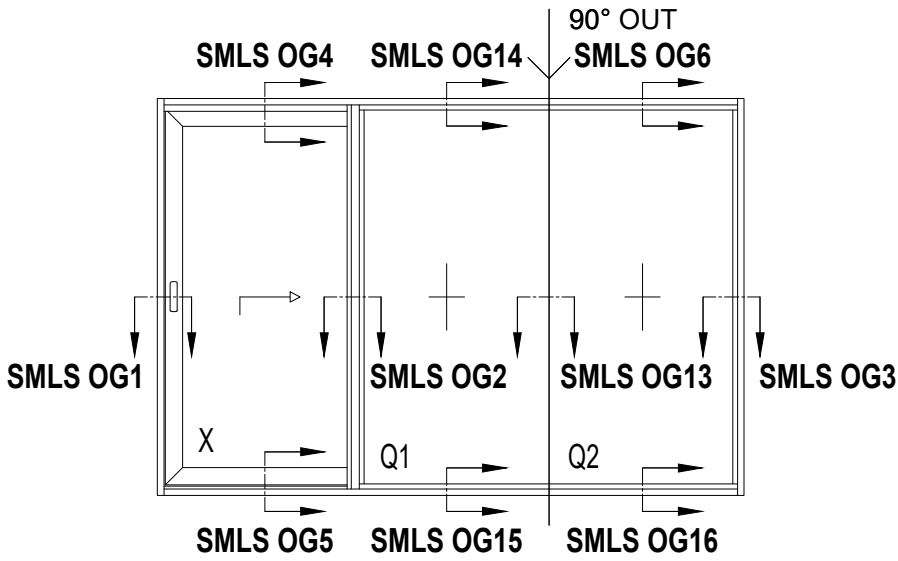

**SMLS OG13**

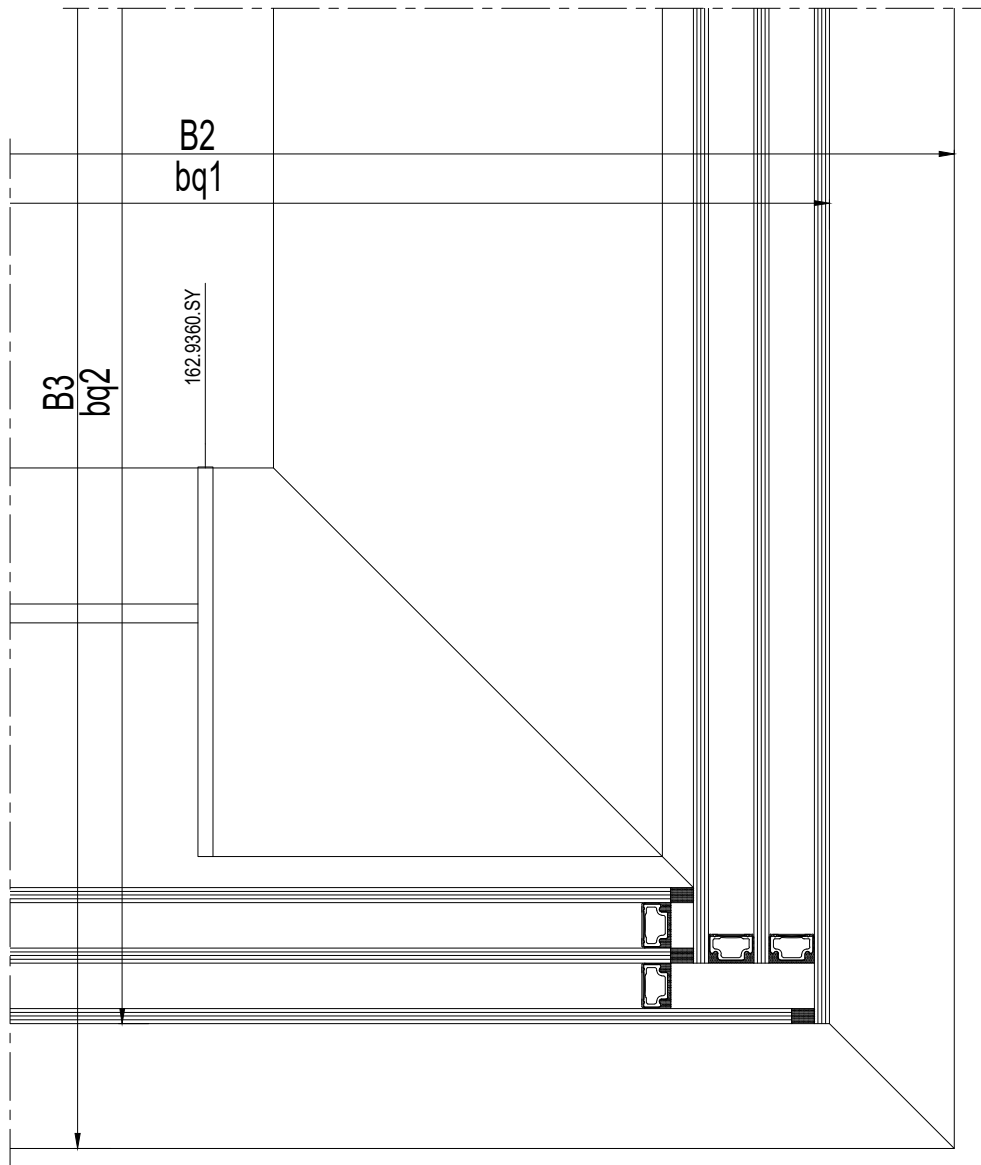

schaal - échelle  
 scale - Maßstab  
 1/2

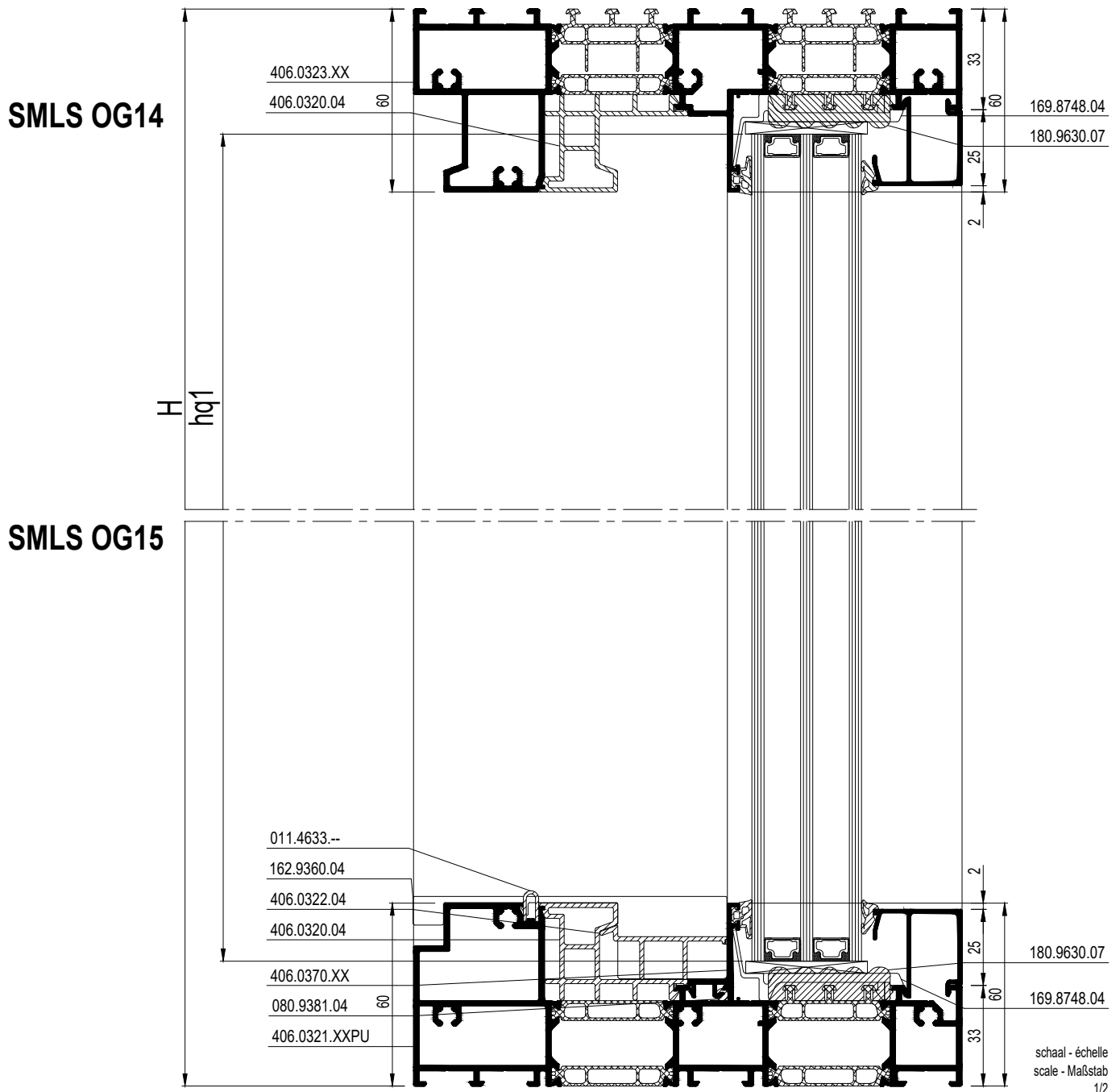

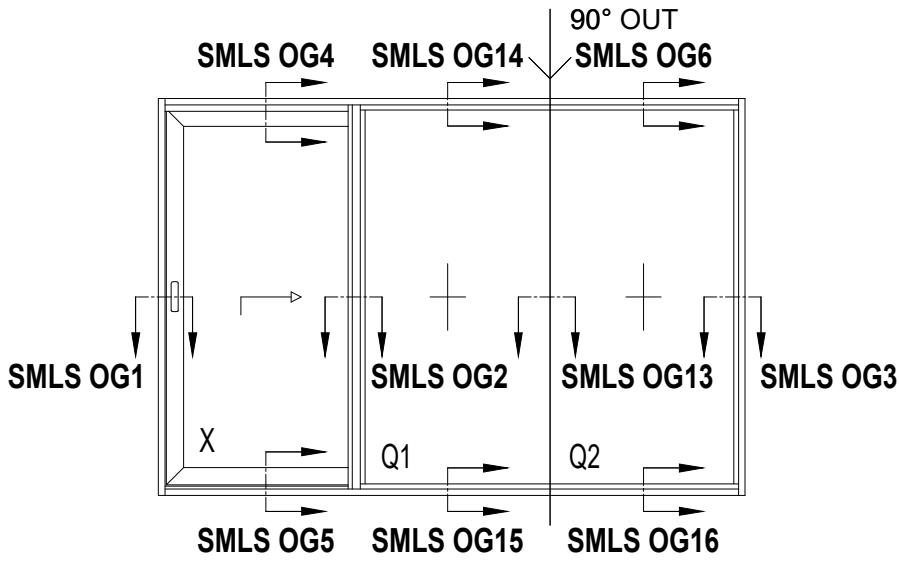



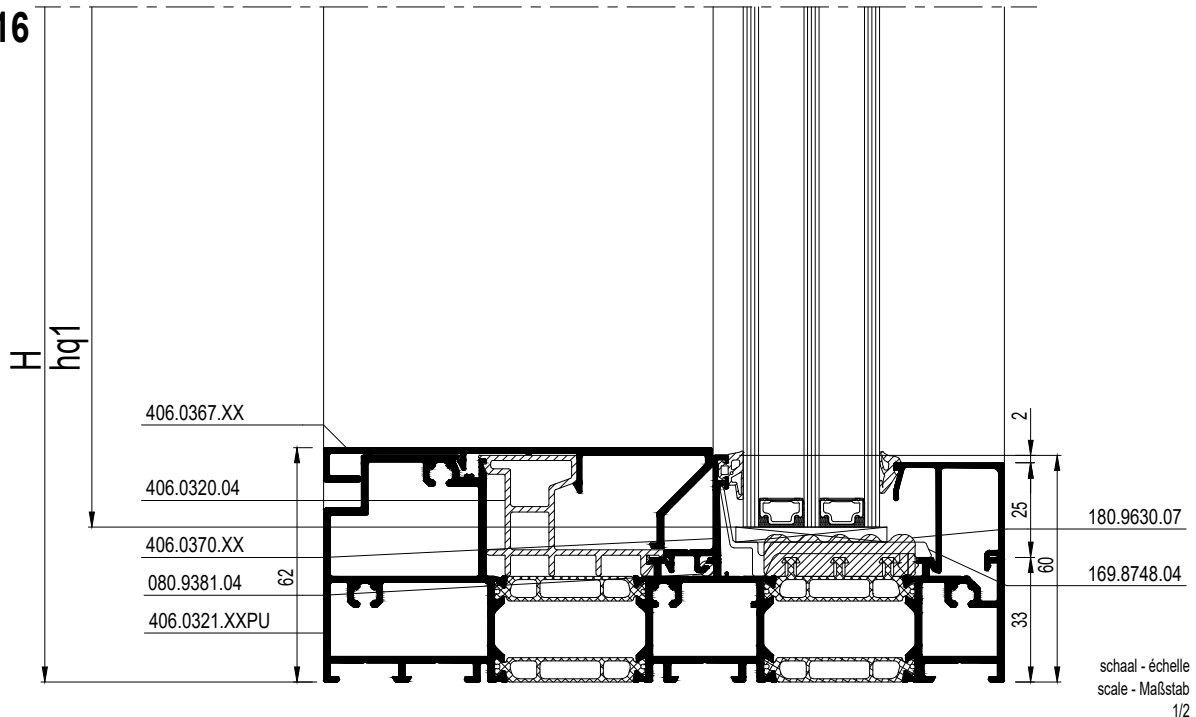



























































**SMLS OG16**































































E

			#	$\leftarrow L_m \rightarrow$
406.0321.XXPU			1	(B1 + B2) - 33
			1	B3 - 33
406.0323.XX			1	(B1 + B2) - 33
			1	B3 - 33
406.0325.XX			1	H
406.0327.XX			1	H
406.0322.04			1	B1-18.5
406.0320.04			1	(B1 + B2) - 123
			1	B3 - 123
			1	B3 - 123
			1	(B1 + B2) - 123
011.4633.--			1	2B1-25
406.0326.04			1	H - 120
406.0324.04			1	H - 120 *
406.0370.XX			1	B2 - 32.5
			1	B3 - 106
406.0365.XX			1	B1 - 77
406.0366.XX			1	B1 - 77
406.0367.XX			1	B3 - 110.5
			1	B2-B1-103
406.0340.XX			1	H - 106
			1	B1 + 3.5 (-20)
			1	B1 + 3.5 (-20)
406.0343.04			1	H - 176
030.3613.XX			2	H - 276
			2	B1 - 116.5
			2	H - 116
			1	B2 - 16.5
			1	B3 - 33
			1	B3 - 33
			1	B2 - 16.5
406.0335.XX			1	H - 146
			1	H - 66
406.0341.04			2	H - 106
406.0342.XX			1	H - 154
			1	H - 66
0M0.1505.00			1	 34G.F

BX = B1+3.5
HX = H-106
bx = BX-136
bq1 = B2-57.5
bq2 = B3-74
hx = HX-136
hq = H-82

\* KNIP IN STUKKEN  
 \* COUPE EN MORCEAUX  
 \* CUT IN PIECES  
 \* IN STUCKE SCHNEIDEN





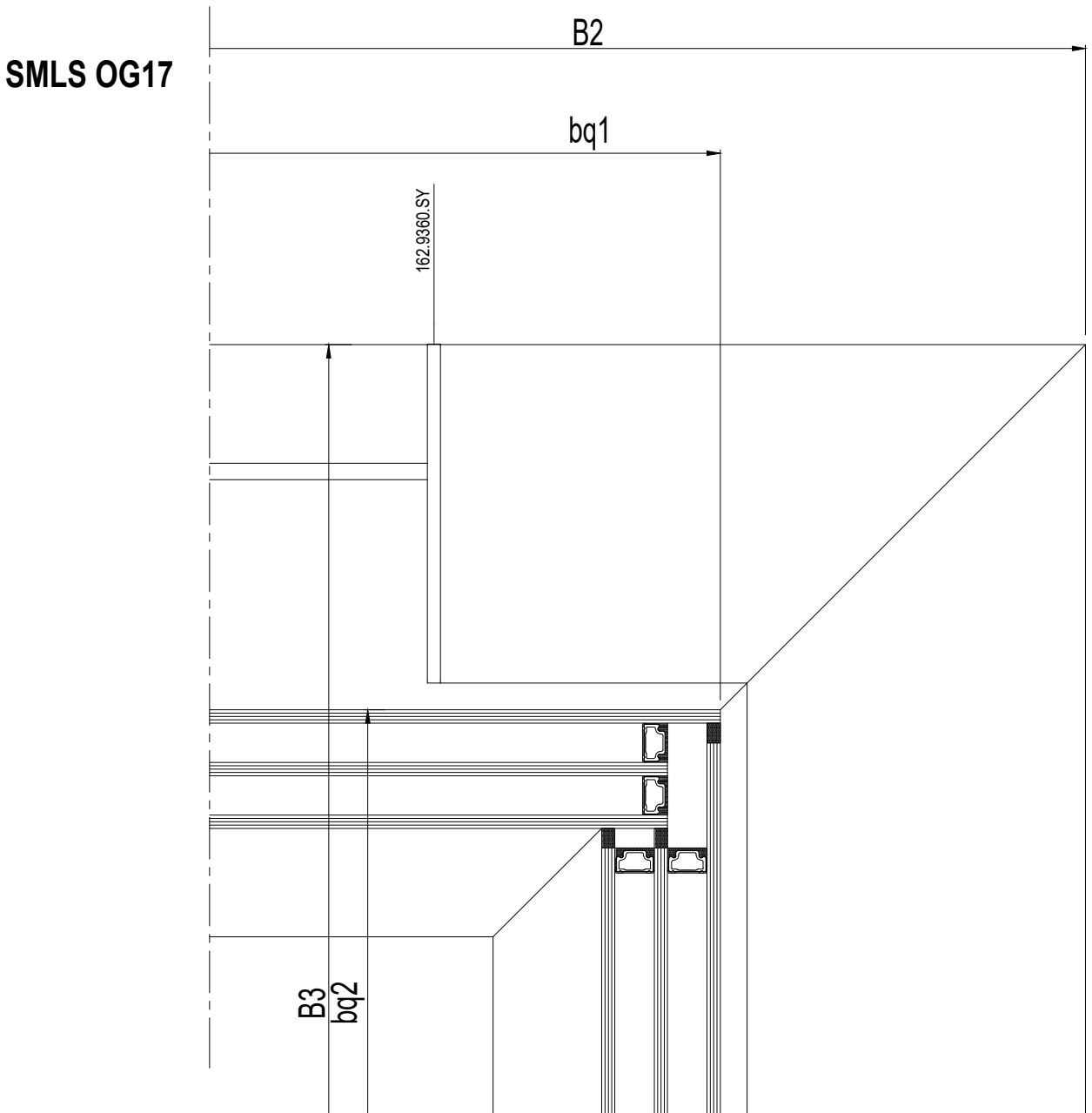
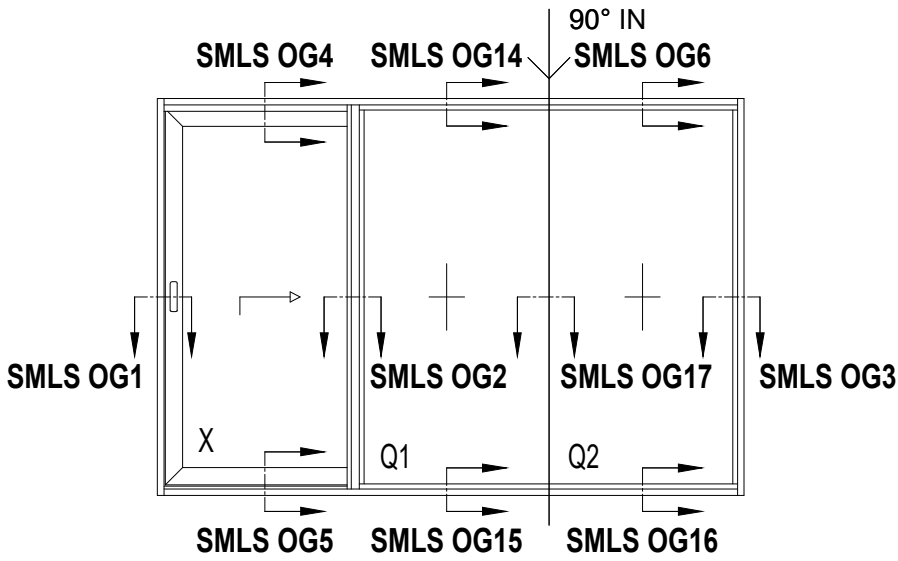























































		#
052.5371.--		16
168.8688.04		4
162.8050.00		4
050.5094.--		16
054.5441.04		16
162.8051.00		2
050.5094.--		16
054.5441.04		16
168.8932.00		2
168.8748.00		2
168.5012.--		2
168.8675.04		2
168.8105.00		4
168.5012.--		4
168.8106.00		4
050.5091.--		8
160.8725.--		4
160.8750.--		8
160.8745.00		2
052.5300.--		2 x (H / 300)
162.7980.04		5
162.7990.04		3
169.8748.04		16
162.9355.04		6
080.9124.SY		2B + 4H
080.9381.04		B + 2H
180.9114.SY		2B + 4H
080.9738.04		2
084.9440.07		H - 159 H - 66
084.9439.07		B1 - 65
087.9853.07		2 x (H - 160)
180.9630.07		2B + 4H
Lock set		1
Wheels set		1
162.7930.--		min. 1
162.8035.04		1
052.5309.--		2
162.9060.SY		1
162.9061.04		1

		#
162.8081.04		2
162.8064.04		1
162.9360.SY		1
162.9310.04		4
180.9160.04		2B1 - 25
062.7715.XX		 34G.F
180.9410.04		B1
180.9412.04		B1 + 4H
180.9414.04		2B1
180.9416.04		2B1 + 2H
180.9493.04		1
062.7715.XX		 34G.F
069.6830.04		 34G.F











































schaal - échelle  
 scale - Maßstab  
 1/2



















			#	$\leftarrow L_m \rightarrow$
406.0321.XXPU			1	(B1 + B2) - 33
			1	B3 - 33
406.0323.XX			1	(B1 + B2) - 33
			1	B3 - 33
406.0325.XX			1	H
406.0327.XX			1	H
406.0322.04			1	B1-18.5
406.0320.04			1	(B1 + B2) - 74
			1	B3 - 74
			1	B3 - 74
			1	(B1 + B2) - 74
011.4633.--			1	2B1-25
406.0326.04			1	H - 120
406.0324.04			1	H - 120 *
406.0370.XX			1	B2 - 49.5
			1	B3 - 123
406.0365.XX			1	B1 - 77
406.0366.XX			1	B1 - 77
406.0367.XX			1	B3 - 33.5
			1	B2-B1-26
406.0340.XX			1	H - 106
			1	B1 + 3.5 (-20)
			1	B1 + 3.5 (-20)
406.0343.04			1	H - 176
030.3613.XX			2	H - 276
			2	B1 - 116.5
			2	H - 116
			1	B2 - 170.5
			1	B3 - 187
			1	B3 - 187
			1	B2 - 170.5
406.0335.XX			1	H - 146
			1	H - 66
406.0341.04			2	H - 106
406.0342.XX			1	H - 154
			1	H - 66
0M0.1505.00			1	 34G.F

BX = B1+3.5
HX = H-106
bx = BX-136
bq1 = B2-135.5
bq2 = B3-152
hx = HX-136
hq = H-82

\* KNIP IN STUKKEN  
 \* COUPE EN MORCEAUX  
 \* CUT IN PIECES  
 \* IN STUCKE SCHNEIDEN

		#
052.5371.--		16
168.8688.04		4
162.8050.00		4
050.5094.--		16
054.5441.04		16
162.8051.00		2
050.5094.--		16
054.5441.04		16
168.8932.00		2
168.8748.00		2
168.5012.--		2
168.8675.04		2
168.8105.00		4
168.5012.--		4
168.8106.00		4
050.5091.--		8
160.8725.--		4
160.8750.--		8
160.8745.00		2
052.5300.--		2 x (H / 300)
162.7980.04		5
162.7990.04		3
169.8748.04		16
162.9355.04		6
080.9124.SY		2B + 4H
080.9381.04		B + 2H
180.9114.SY		2B + 4H
080.9738.04		2
084.9440.07		H - 159 H - 66
084.9439.07		B1 - 65
087.9853.07		2 x (H - 160)
180.9630.07		2B + 4H
Lock set		1
Wheels set		1
162.7930.--		min. 1
162.8035.04		1
052.5309.--		2
162.9060.SY		1
162.9061.04		1

		#
162.8081.04		2
162.8064.04		1
162.9360.SY		1
162.9310.04		4
180.9160.04		2B1 - 25
180.9410.04		B1
180.9412.04		B1 + 4H
180.9414.04		2B1
180.9416.04		2B1 + 2H
180.9493.04		1
062.7715.XX		 34G.F
069.6830.04		 34G.F

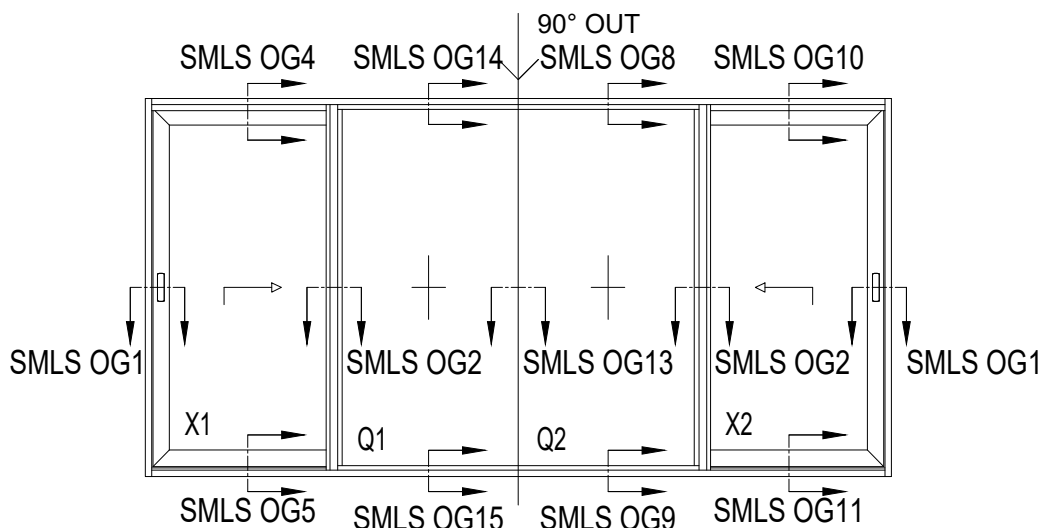

























































BX1 = B1+3.5
BX2 = B4+3.5
HX = H-106
bx1 = BX1-136
bq1 = B2-57.5
bq2 = B3-57.5
bx2 = BX2-136
hx = HX-136
hq = H-82

			#	$\leftarrow L_m \rightarrow$
406.0321.XXPU			1	(B1 + B2) - 33
			1	(B3 + B4) - 33
406.0323.XX			1	(B1 + B2) - 33
			1	(B3 + B4) - 33
406.0325.XX			2	H
406.0322.04			1	B2 - 117.5
			1	B3 - 117.5
406.0320.04			1	(B1 + B2) - 123
			1	(B3 + B4) - 123
			1	(B3 + B4) - 123
			1	(B1 + B2) - 123
011.4633.--			1	(B1 + B2) - 186
			1	(B3 + B4) - 186
406.0326.04			2	H - 120
406.0324.04			2	H - 120 *
406.0370.XX			1	B2 - 32.5
			1	B3 - 32.5
406.0365.XX			1	B1 - 77
			1	B4 - 77
406.0366.XX			1	B1 - 77
			1	B4 - 77
406.0340.XX			4	H - 106
			1	B1 + 3.5 (-20)
			1	B1 + 3.5 (-20)
			1	B4 + 3.5 (-20)

			#	$\leftarrow L_m \rightarrow$
406.0343.04			2	H - 176
030.3613.XX			4	H - 276
			2	B1 - 116.5
			2	H - 116
			1	B2 - 16.5
			1	B2 - 16.5
			1	B3 - 16.5
406.0335.XX			2	H - 146
			2	H - 66
406.0341.04			4	H - 106
406.0342.XX			2	H - 154
			2	H - 66
0M0.1505.00			2	34G.F

\* KNIP IN STUKKEN  
 \* COUPE EN MORCEAUX  
 \* CUT IN PIECES  
 \* IN STUCKE SCHNEIDEN

		#
052.5371.--		16
162.8050.00		4
050.5094.--		16
054.5441.04		16
162.8051.00		2
050.5094.--		16
054.5441.04		16
168.8932.00		4
168.8748.00		4
168.5012.--		4
168.8688.04		8
168.8105.00		8
168.5012.--		8
168.8106.00		8
050.5091.--		16
160.8725.--		8
160.8750.--		12
160.8745.00		2
052.5300.--		4 x (H / 300)
162.7980.04		10
162.7990.04		5
169.8748.04		20
162.9355.04		12
080.9124.SY		2B + 6H
080.9381.04		B + 4H
180.9114.SY		2B + 6H
080.9738.04		2
084.9440.07		2 x (H - 159) 2 x (H - 66)
084.9439.07		B1 - 65 B4 - 65
087.9853.07		4 x (H - 160)
180.9630.07		2B + 6H
Lock set		2
Wheels set		2
162.7930.--		min. 2
162.8035.04		2
052.5309.--		4
162.9060.SY		2
162.9061.04		2

		#
162.8081.04		4
162.8064.04		1
162.8065.04		1
162.9310.04		4
180.9160.04		B
180.9410.04		B1 + B4
180.9412.04		B1 + B4 + 8H
180.9414.04		2B1 + 2B4
180.9416.04		2B1+2B4+4H
180.9493.04		2
062.7715.XX		 34G.F
069.6830.04		 34G.F

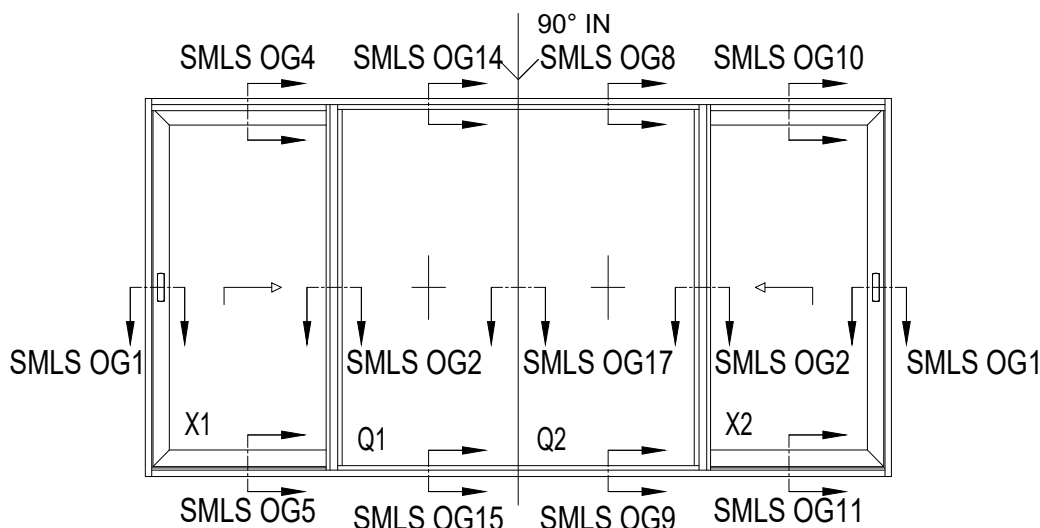

























































BX1 = B1+3.5
BX2 = B4+3.5
HX = H-106
bx1 = BX1-136
bq1 = B2-135.5
bq2 = B3-135.5
bx2 = BX2-136
hx = HX-136
hq = H-82

			#	$\leftarrow L_m \rightarrow$
406.0321.XXPU			1	(B1 + B2) - 33
			1	(B3 + B4) - 33
406.0323.XX			1	(B1 + B2) - 33
			1	(B3 + B4) - 33
406.0325.XX			2	H
406.0322.04			1	B2 - 102
			1	B3 - 102
406.0320.04			1	(B1 + B2) - 74
			1	(B3 + B4) - 74
			1	(B3 + B4) - 74
			1	(B1 + B2) - 74
011.4633.--			1	(B1 + B2) - 83
			1	(B3 + B4) - 83
406.0326.04			2	H - 120
406.0324.04			2	H - 120 *
406.0370.XX			1	B2 - 49.5
			1	B3 - 49.5
406.0365.XX			1	B1 - 77
			1	B4 - 77
406.0366.XX			1	B1 - 77
			1	B4 - 77
406.0340.XX			4	H - 106
			1	B1 + 3.5 (-20)
			1	B1 + 3.5 (-20)
			1	B4 + 3.5 (-20)

			#	$\leftarrow L_m \rightarrow$
406.0343.04			2	H - 176
030.3613.XX			4	H - 276
			2	B1 - 116.5
			2	H - 116
			1	B2 - 170.5
			1	B2 - 170.5
			1	B3 - 170.5
406.0335.XX			2	H - 146
			2	H - 66
406.0341.04			4	H - 106
406.0342.XX			2	H - 154
			2	H - 66
0M0.1505.00			2	34G.F

\* KNIP IN STUKKEN  
 \* COUPE EN MORCEAUX  
 \* CUT IN PIECES  
 \* IN STUCKE SCHNEIDEN

		#
052.5371.--		16
162.8050.00		4
050.5094.--		16
054.5441.04		16
162.8051.00		2
050.5094.--		16
054.5441.04		16
168.8932.00		4
168.8748.00		4
168.5012.--		4
168.8688.04		8
168.8105.00		8
168.5012.--		8
168.8106.00		8
050.5091.--		16
160.8725.--		8
160.8750.--		12
160.8745.00		2
052.5300.--		4 x (H / 300)
162.7980.04		10
162.7990.04		5
169.8748.04		20
162.9355.04		12
080.9124.SY		2B + 6H
080.9381.04		B + 4H
180.9114.SY		2B + 6H
080.9738.04		2
084.9440.07		2 x (H - 159) 2 x (H - 66)
084.9439.07		B1 - 65 B4 - 65
087.9853.07		4 x (H - 160)
180.9630.07		2B + 6H
Lock set		2
Wheels set		2
162.7930.--		min. 2
162.8035.04		2
052.5309.--		4
162.9060.SY		2
162.9061.04		2

		#
162.8081.04		4
162.8064.04		1
162.8065.04		1
162.9310.04		4
180.9160.04		B
180.9410.04		B1 + B4
180.9412.04		B1 + B4 + 8H
180.9414.04		2B1 + 2B4
180.9416.04		2B1+2B4+4H
180.9493.04		2
062.7715.XX		 34G.F
069.6830.04		 34G.F

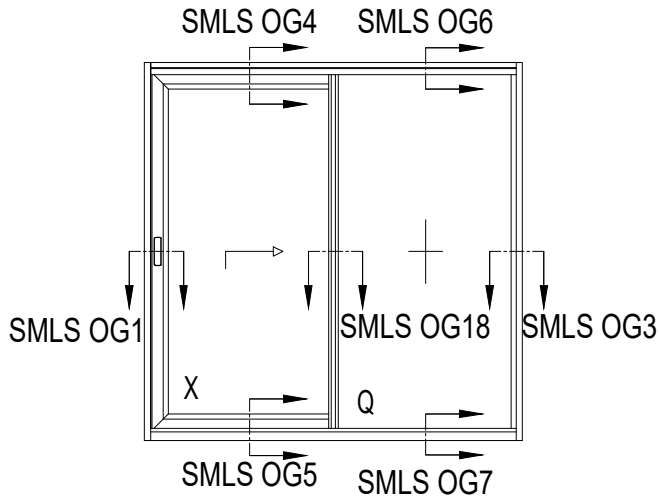

**SMLS OG18**

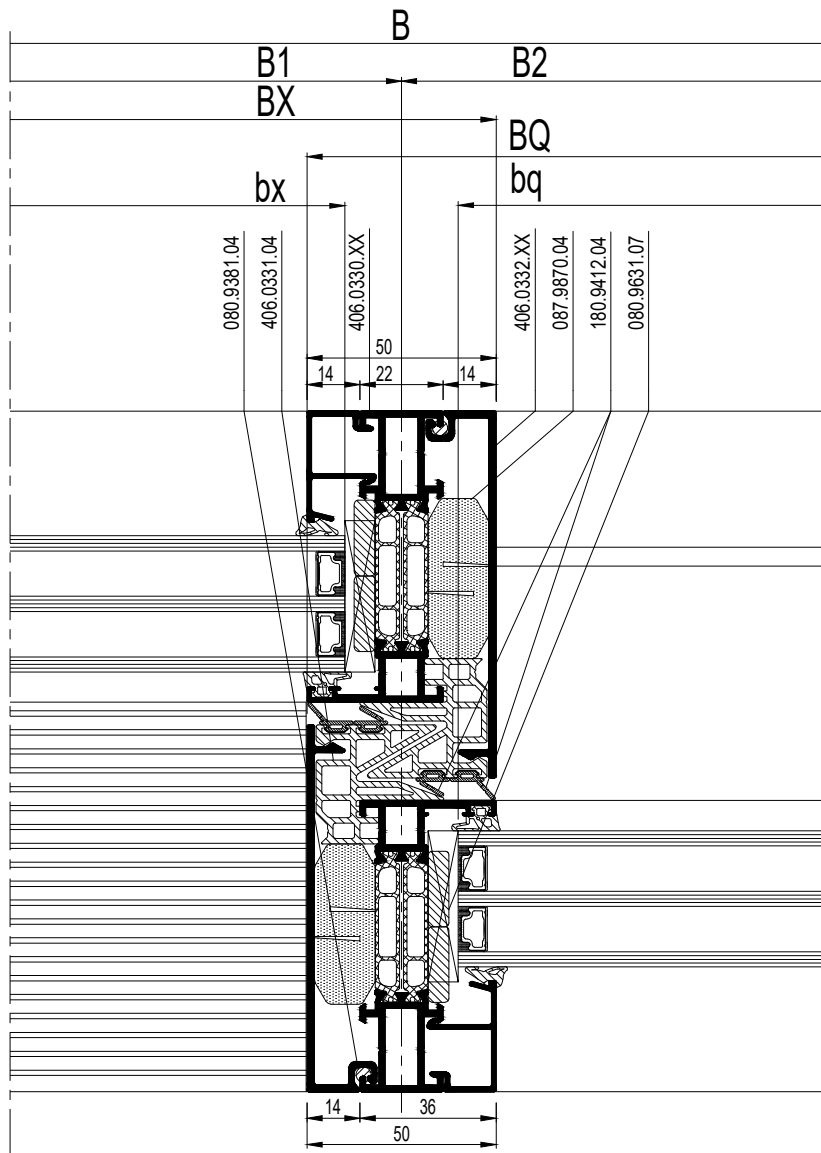

schaal - échelle  
 scale - Maßstab  
 1/2

			#	
406.0321.XXPU			1	B-66
406.0323.XX			1	B-66
406.0325.XX			1	H
406.0327.XX			1	H
406.0322.04			1	B2 - 55
406.0320.04			2	B - 66
011.4633.--			1	B - 80
406.0326.04			1	H - 120
406.0324.04			1	H - 120 *
406.0370.XX			1	B2 - 11
406.0365.XX			1	B1 - 58.5
406.0366.XX			1	B1 - 58.5
406.0340.XX			1	H - 106
			1	B1 - 29
			1	B1 - 29
406.0343.04			1	H - 176
030.3613.XX			1	H - 276
			2	B1 - 111
			2	B2 - 44
			1	H - 116
002.0687.XX			1	H - 276
			1	H - 116
406.0330.XX			1	H - 226
			1	H - 66
406.0331.04			2	H - 106
406.0332.XX			1	H - 154
			1	H - 66
0M0.1505.00			1	34G.F

\* KNIP IN STUKKEN  
 \* COUPE EN MORCEAUX  
 \* CUT IN PIECES  
 \* IN STÜCKE SCHNEIDEN

BX = B1-15
BQ = B2+25
HX = H-106
bx = BX-108
bq = BQ-81
hx = HX-136
hq = H-82

		#
052.5371.--		16
068.8932.00		4
168.8725.00		2
168.5012.--		1
168.8727.00		2
050.5083.--		2
168.5012.--		1
168.8675.04		2
168.8688.04		2
168.8105.00		2
168.5012.--		2
168.8106.00		2
050.5091.--		4
160.8725.--		4
160.8750.--		4
052.5327.--		2 x (H / 300)
162.7980.04		5
162.7990.04		3
169.8748.04		8
162.9355.04		6
080.9124.SY		2B + 4H
080.9381.04		B + 2H
180.9114.SY		2B + 4H
080.9738.04		2
087.9870.07		H - 159
		H - 66
084.9439.07		B1 - 60.5
087.9853.07		2 x (H - 160)
180.9630.07		2B + 2H
080.9631.07		4H
Lock set		1
Wheels set		1
162.7930.--		min. 1
162.8035.04		1
052.5309.--		2
162.9090.SY		1
162.9091.04		1
162.8081.04		2
162.8074.04		1
162.9310.04		2
180.9160.04		B
180.9410.04		B1
180.9412.04		B1 + 4H
180.9414.04		2B1
180.9416.04		2B1 + 2H
180.9493.04		1
062.7715.XX		34G.F
069.6830.04		34G.F

### MONORAIL OUTSIDE GLAZED - STANDARD BOTTOM

			#	← Lm →
406.0321.XXPU			X	X
406.0370.XX			X	X
406.0365.XX			X	X

### MONORAIL OUTSIDE GLAZED - VARIANT BOTTOM

			#	← Lm →
406.0312.XXPU			X	X
406.0337.XX			X	X

		#
080.9381.04		X

		#
180.9412.04		X
180.9410.04		X

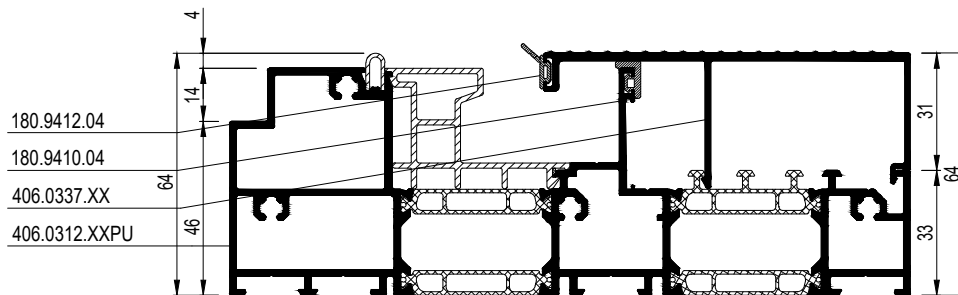
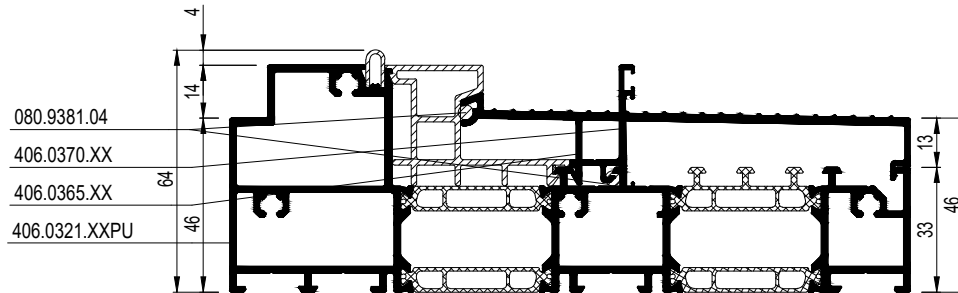

GEMOTORISEERD  
 MOTORISEE

MOTORISED  
 MOTORISIERTES

MONORAIL OUTSIDE GLAZED - STANDARD TOP

			#	$\leftarrow L_m$
406.0323.XX		<input type="checkbox"/>	X	X
406.0320.XX		<input type="checkbox"/>	X	X

MONORAIL OUTSIDE GLAZED - VARIANT TOP

			#	$\leftarrow L_m$
406.0334.XX		<input type="checkbox"/>	X	X
406.0371.XX		<input type="checkbox"/>	X	34G.F
406.0372.04		<input type="checkbox"/>	X	X

EXTRA

		#
080.9381.04		34G.F

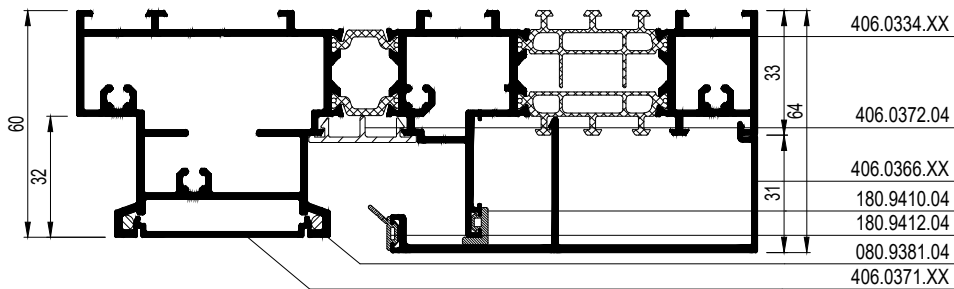
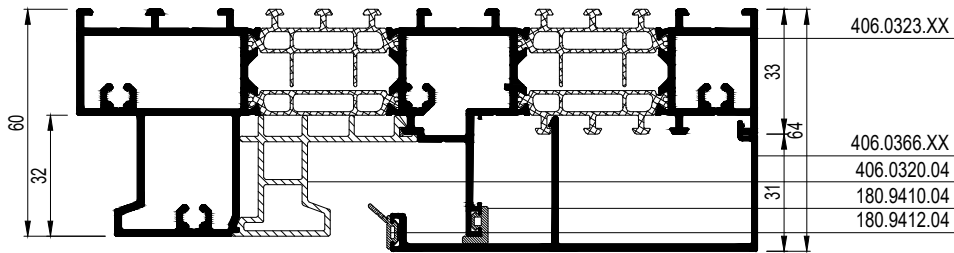

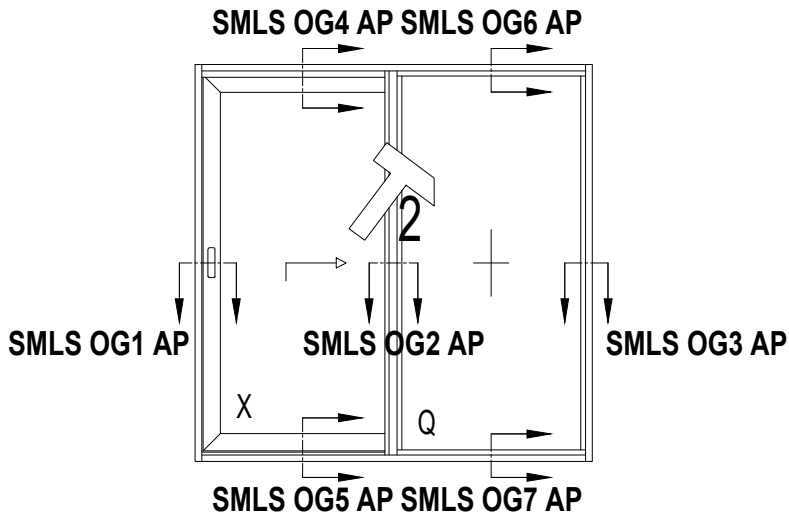

## SMLS OG1 AP

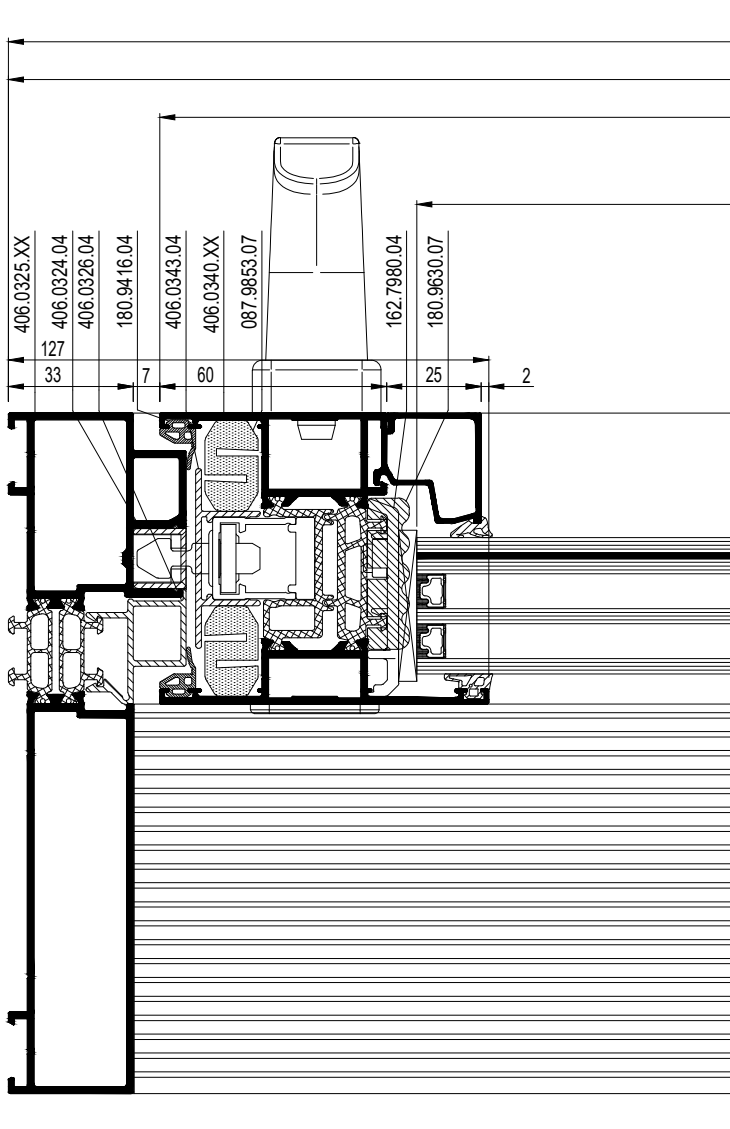

## SMLS OG2 AP

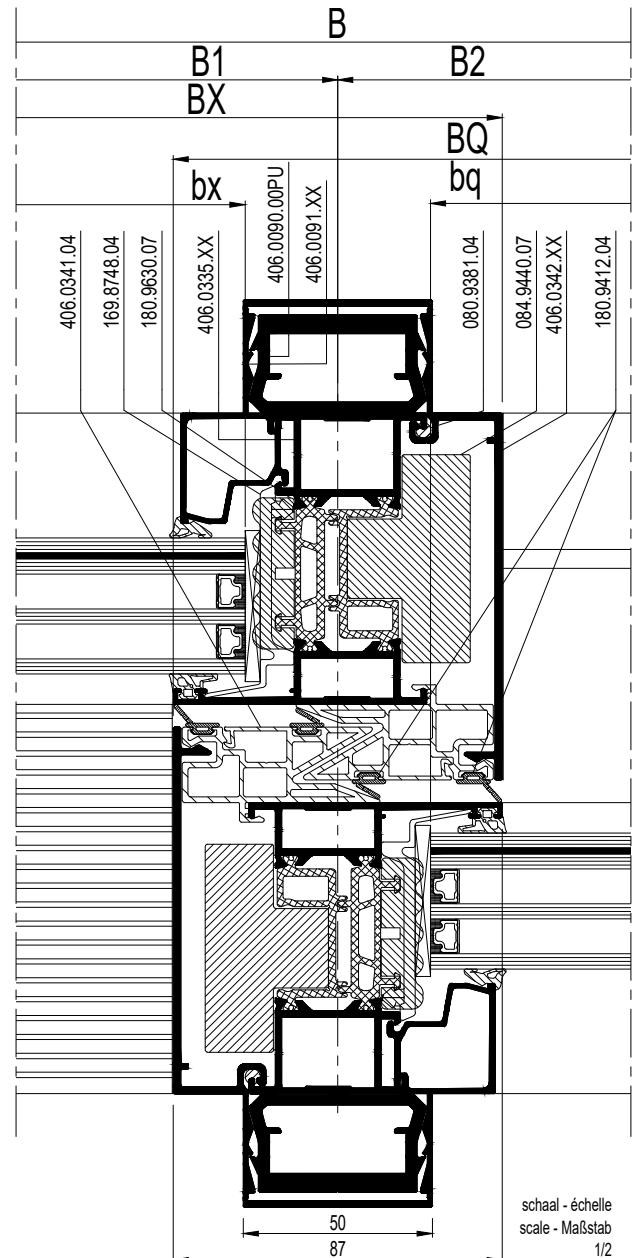

## SMLS OG3 AP

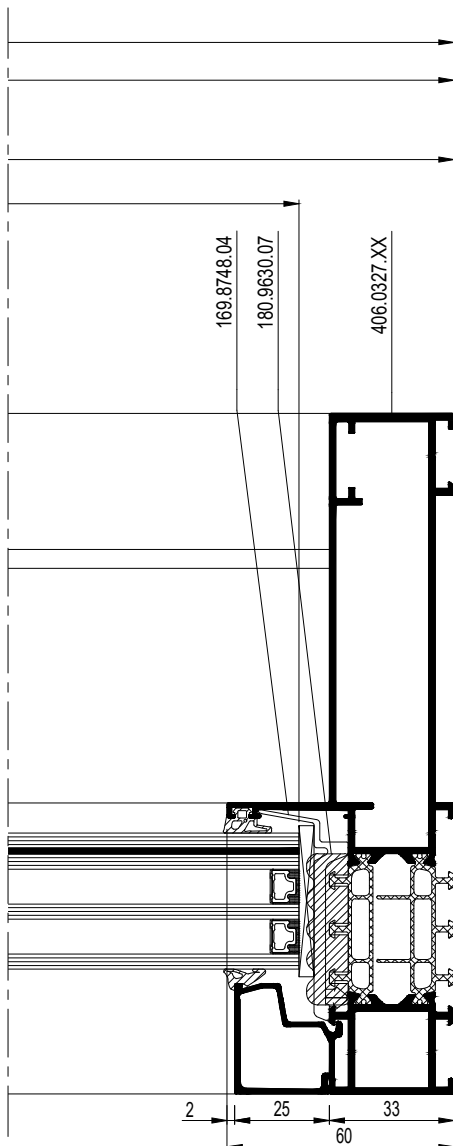

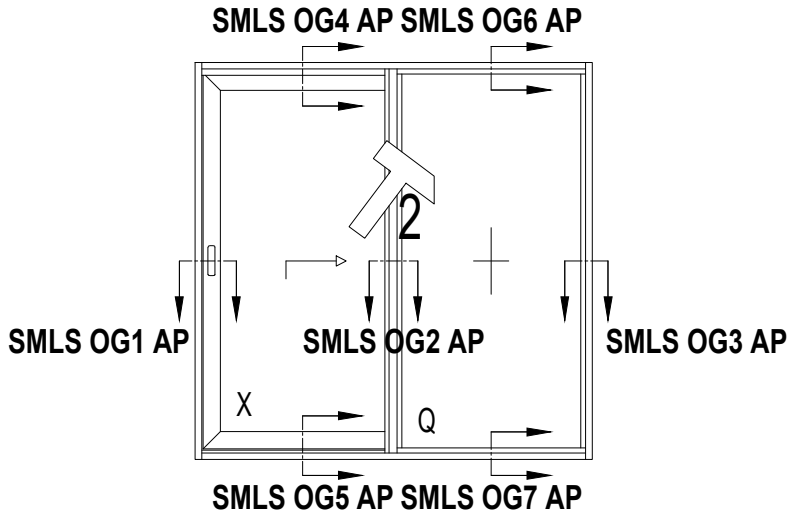

**SMLS OG4 AP**

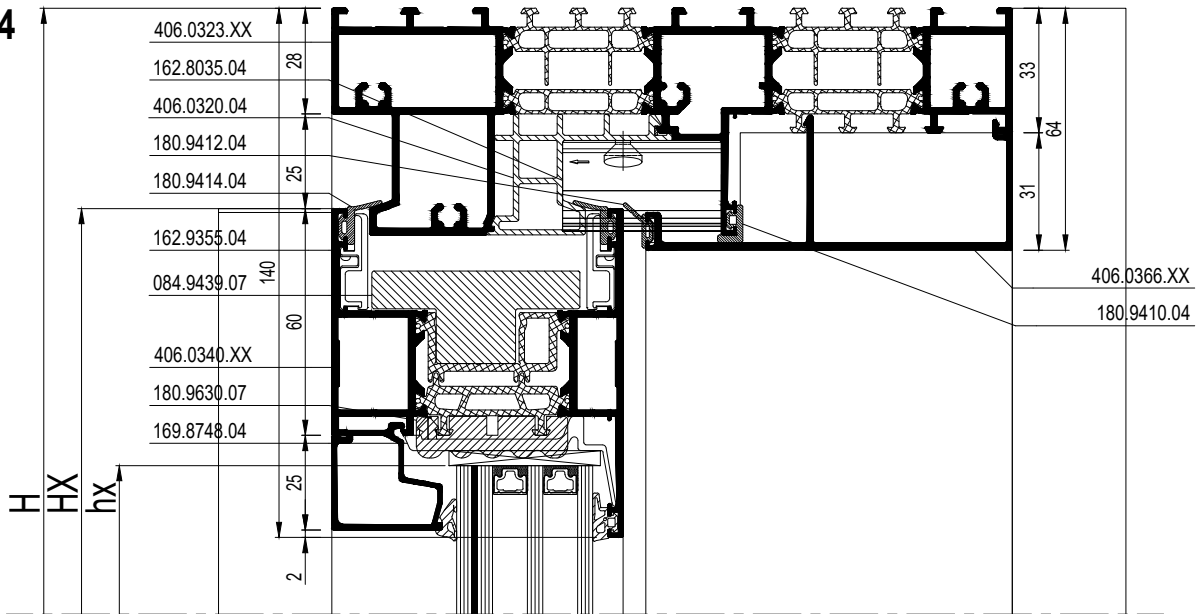

**SMLS OG5 AP**

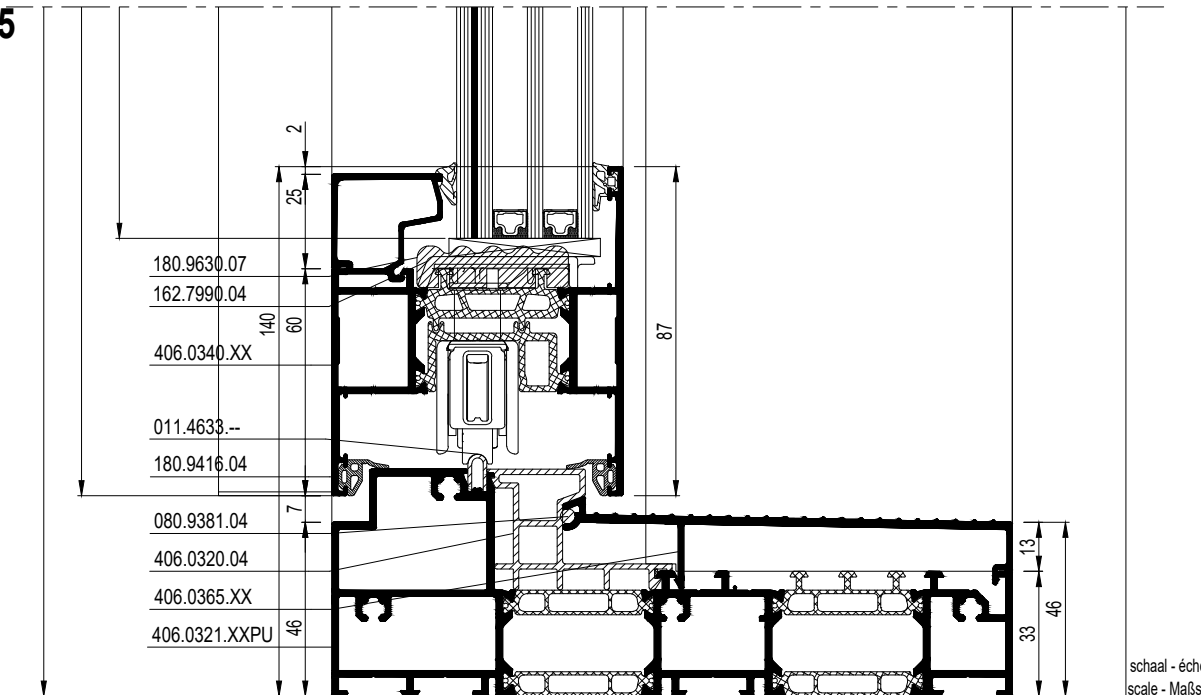

schaal - échelle  
 scale - Maßstab  
 1/2

**SMLS OG6  
AP**

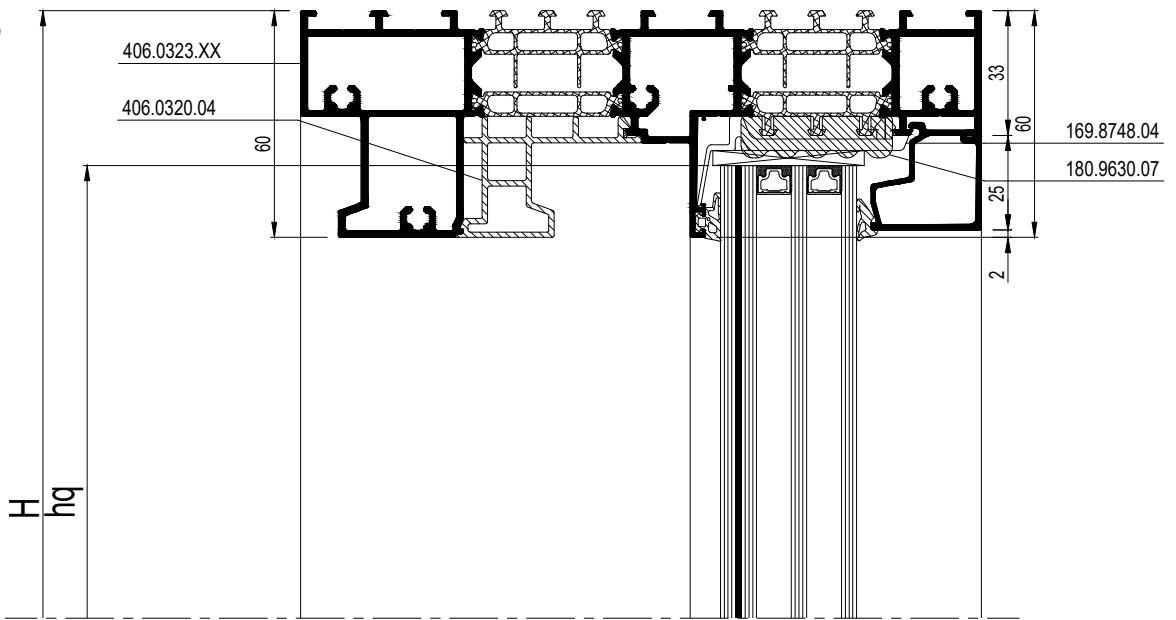



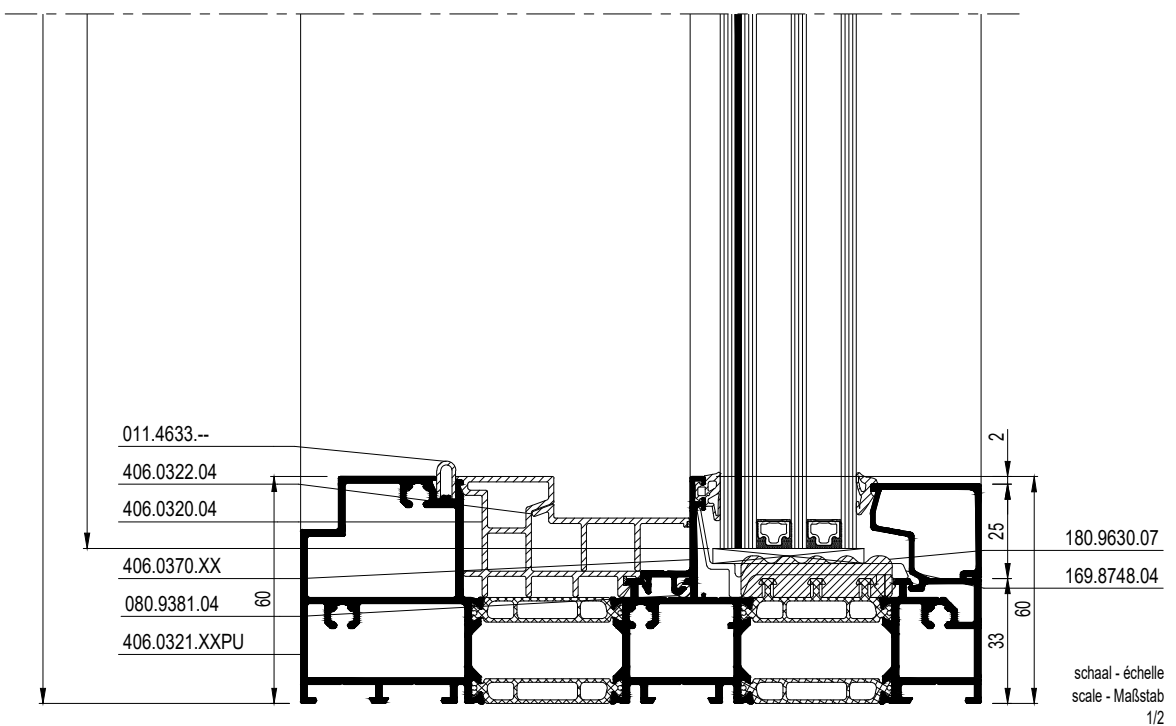

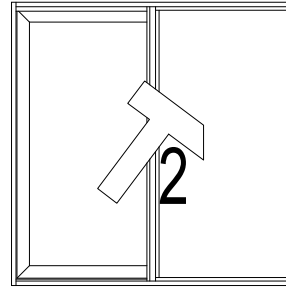
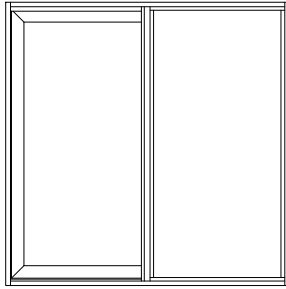



**SMLS OG7  
AP**





































### MONORAIL XQ OUTSIDE/INSIDE GLAZED - STANDARD CHICANE

			#	← Lm →
030.3613.XX			2	H - 276
			2	B1 - 116.5
			2	H - 116
			2	B2 - 49.5

### AP MONORAIL XQ OUTSIDE/INSIDE GLAZED - STANDARD CHICANE

			#	← Lm →
130.3653.XX			2	H - 276
			2	B1 - 116.5
			2	H - 116
			2	B2 - 49.5
406.0090.00PU			1	H-108
			1	H
406.0091.XX			1	H-108
			1	H





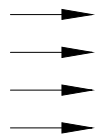

		#
084.9439.07		B1 - 65
162.7930.--		min. 1
169.8748.04		12
162.7980.04		5

		#
084.9439.07		B1 - 200
162.7930.--		2
169.8748.04		14
050.5387.--		9
		2 / Lock point
050.5080.--		8
050.5081.--		8
162.7931.--		34G.F
169.6547.00		min. 6
052.5316.--		min. 18
062.8158.XX		1

EXTRA







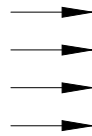







### MONORAIL OUTSIDE/INSIDE GLAZED - STANDARD CHICANE

		#
084.9439.07		B1 - 65
162.7930.--		min. 1 / Vent
169.8748.04		x
162.7980.04		5 / Vent









### AP MONORAIL OUTSIDE/INSIDE GLAZED - STANDARD CHICANE

		#
084.9439.07		B1 - 200
162.7930.--		2 / Vent
169.8748.04		x + 2 / Vent
050.5387.--		9 / X-Vent 2 / Lock point
050.5080.--		8 / Lock on frame
050.5081.--		8 / Vent
162.7931.--		34G.F
169.6547.00		min. 6 / Vent
052.5316.--		min. 18 / Vent
062.8158.XX		1 / 2-Vents







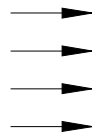





EXTRA

### MONORAIL OUTSIDE/INSIDE GLAZED - SLIM CHICANE

		#
084.9439.07		B1 - 65
162.7930.--		min. 1 / Vent
169.8748.04		x
162.7980.04		5 / Vent



### AP MONORAIL OUTSIDE/INSIDE GLAZED - SLIM CHICANE

		#
084.9439.07		B1 - 200
162.7930.--		2 / Vent
169.8748.04		x + 2 / Vent
050.5387.--		9 / X-Vent 2 / Lock point
050.5080.--		8 / Lock on frame
050.5081.--		8 / Vent
162.7931.--		34G.F
169.6547.00		min. 4 / Vent
052.5316.--		min. 12 / Vent
062.8158.XX		1 / 2-Vents

EXTRA

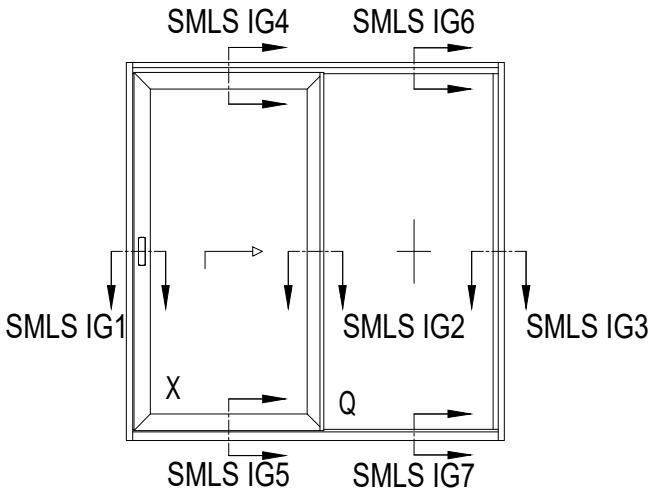

**SMLS IG1**

**SMLS IG2**

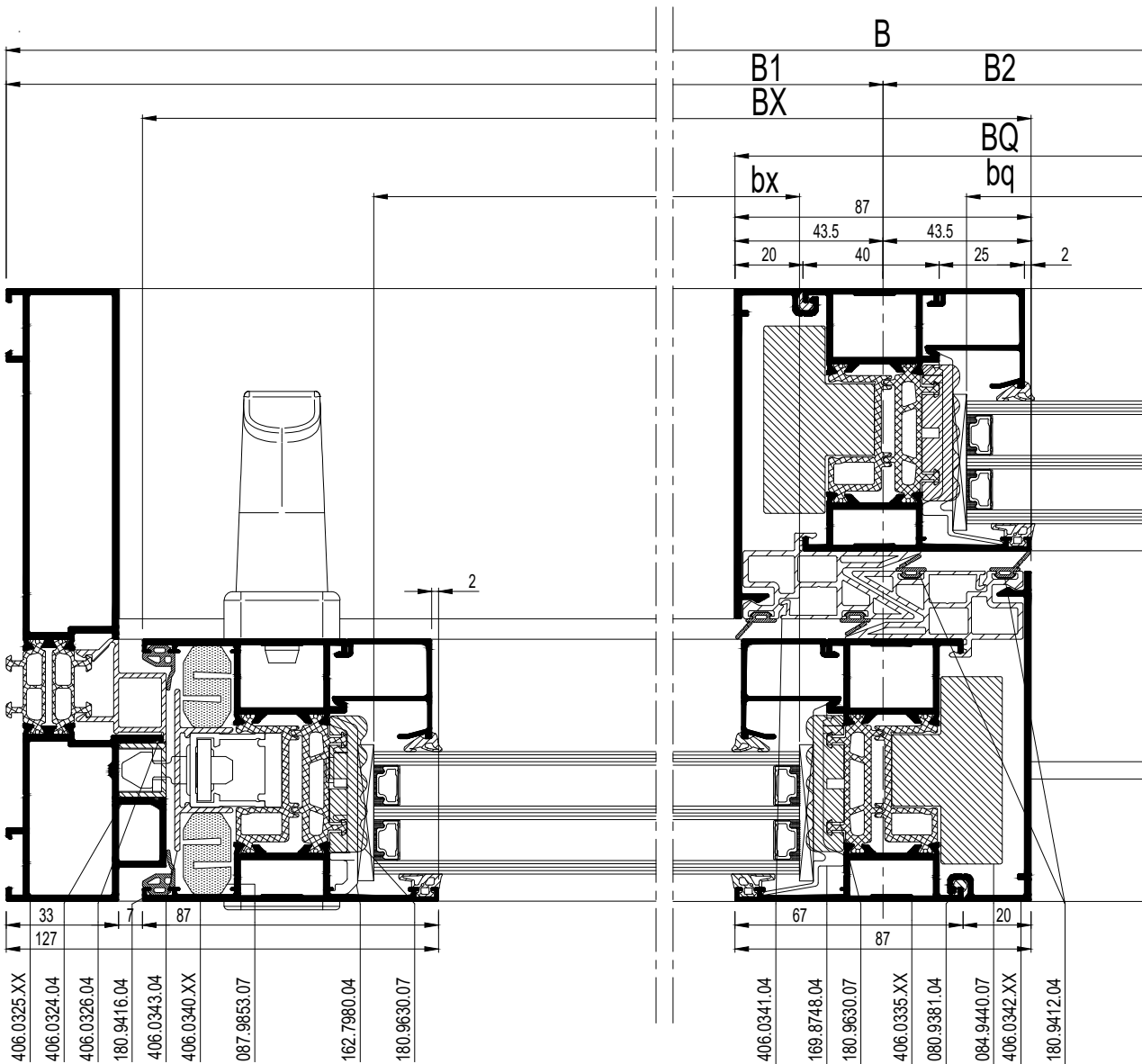

schaal - échelle  
 scale - Maßstab  
 1/2

## SMLS IG3

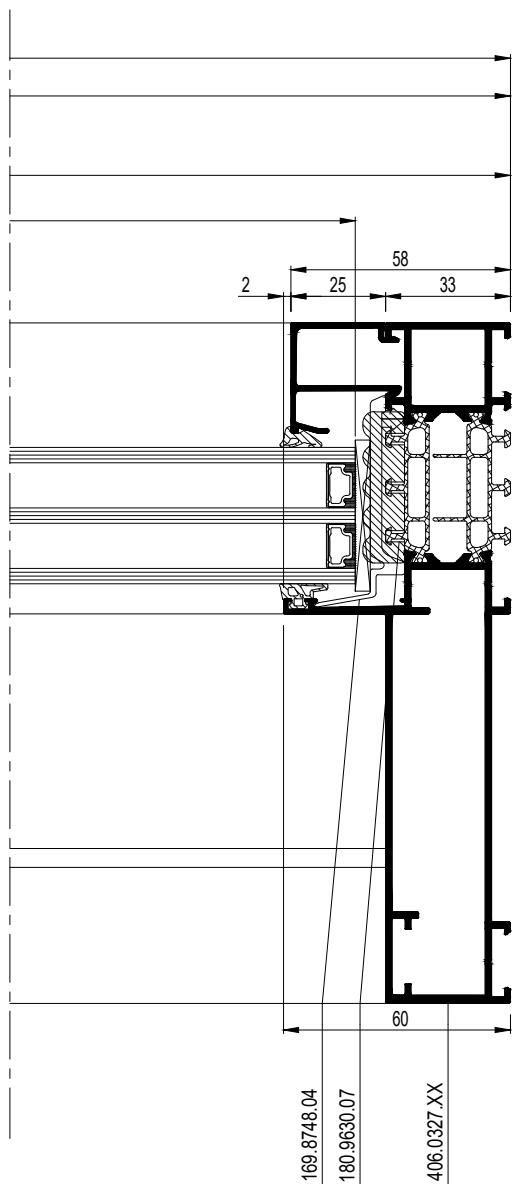

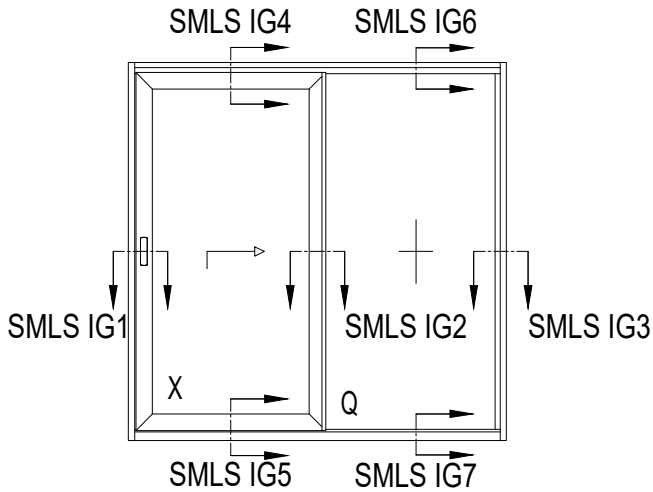

**SMLS IG4**

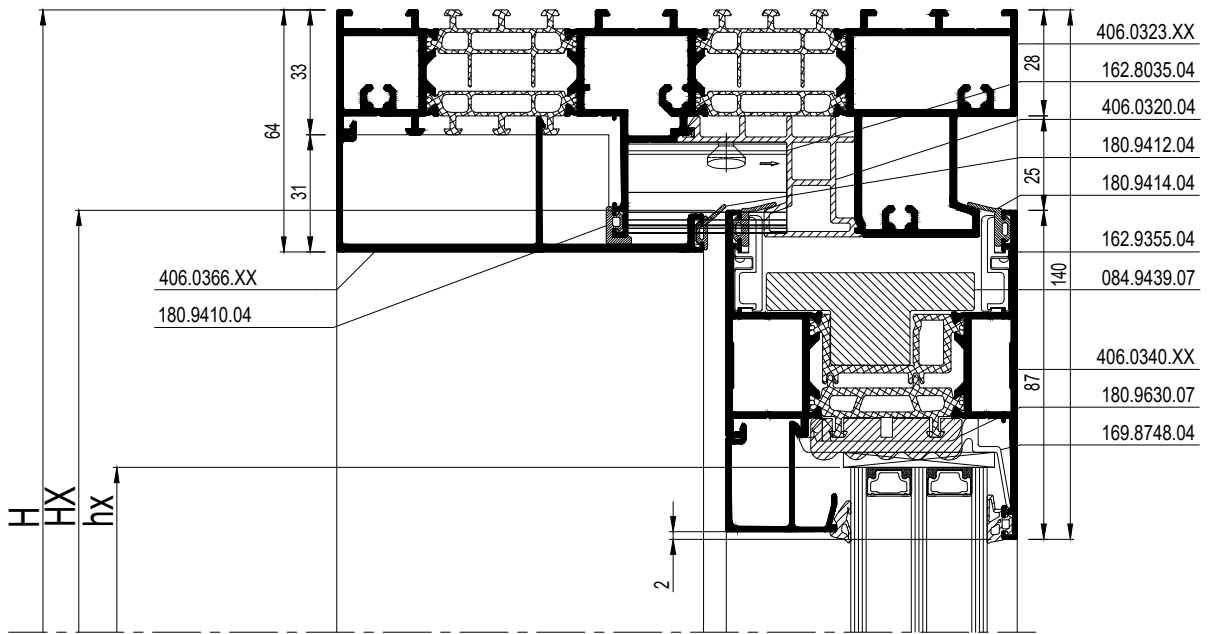

**SMLS IG5**

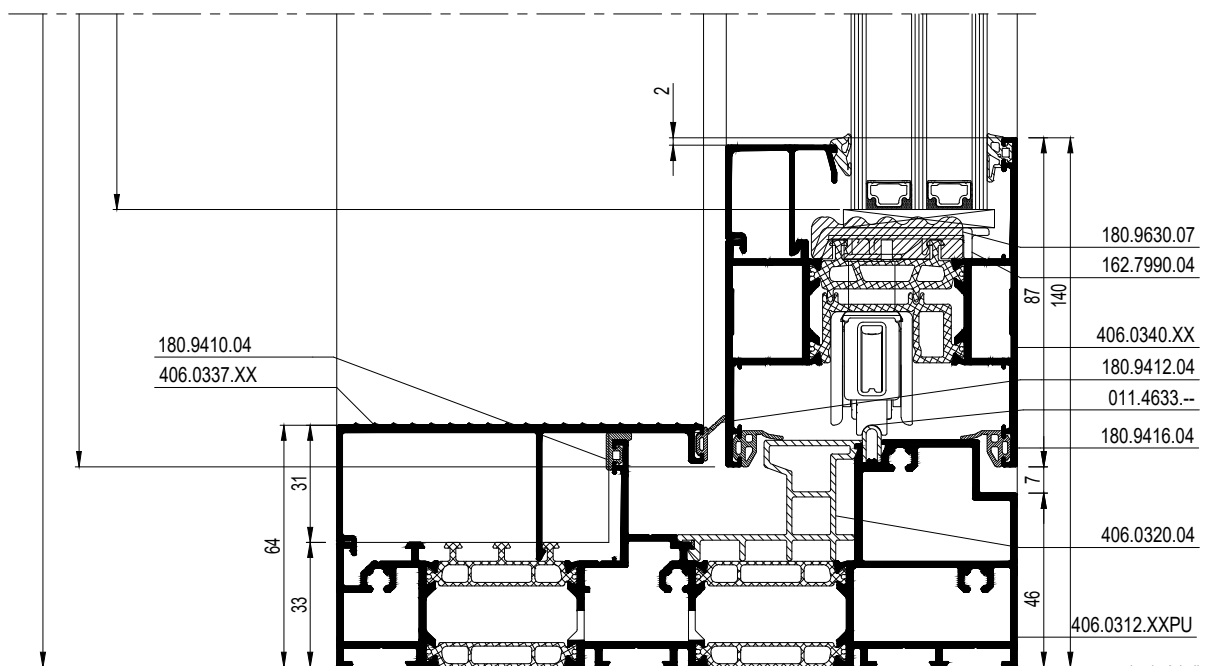

schaal - échelle  
 scale - Maßstab  
 1/2

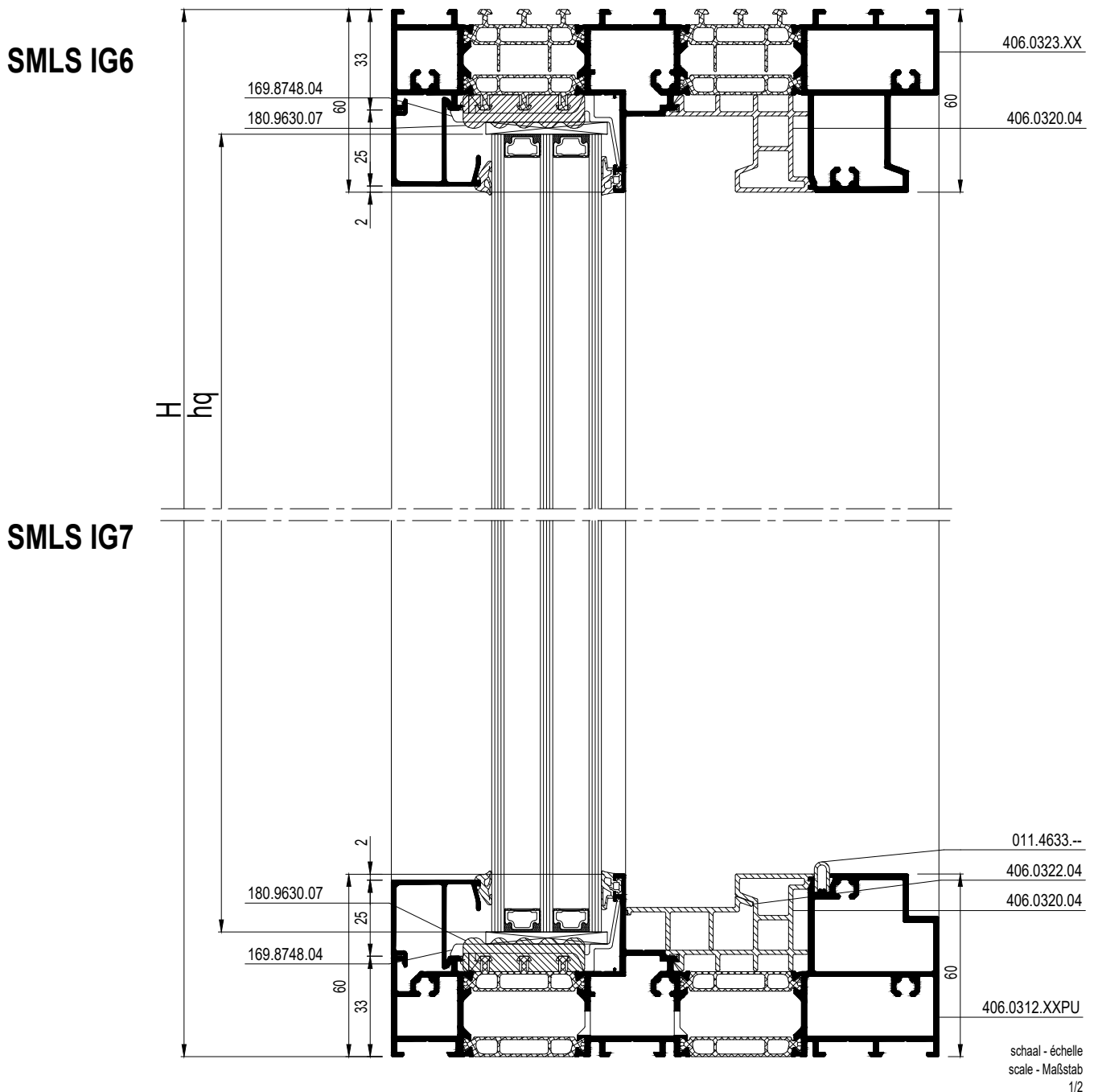

			#	$\leftarrow L_m$
406.0312.XXPU			1	B-66
406.0323.XX			1	B-66
406.0325.XX			1	H
406.0327.XX			1	H
406.0322.04			1	B2 - 78.5
406.0320.04			2	B - 66
011.4633.--			1	B - 80
406.0326.04			1	H - 120
406.0324.04			1	H - 120 *
406.0337.XX			2	B1 - 77
406.0340.XX			1	H - 106
			1	B1 + 3.5 (-20)
			1	B1 + 3.5 (-20)
406.0343.04			1	H - 176
030.3613.XX			2	H - 276
			2	B1 - 116.5
			2	H - 116
			2	B2 - 49.5
406.0335.XX			1	H - 146
			1	H - 66
406.0341.04			2	H - 106
406.0342.XX			1	H - 154
			1	H - 66
OM0.1505.00			1	34G.F

	BX = B1+3.5
	BQ = B2+43.5
	HX = H-106
	bx = BX-136
	bq = BQ-109
	hx = HX-136
	hq = H-82

		#
052.5371.--		16
168.8688.04		4
168.8932.00		2
168.8748.00		2
168.5012.--		2
168.8675.04		2
168.8105.00		4
168.5012.--		4
168.8106.00		4
050.5091.--		8
160.8725.--		4
160.8750.--		8
052.5300.--		2 x (H / 300)
162.7980.04		5
162.7990.04		3
169.8748.04		12
162.9355.04		6
080.9126.SY		2B + 4H
080.9381.04		2H
180.9114.SY		2B + 4H
080.9738.04		2
084.9440.07		H - 159 H - 66
084.9439.07		B1 - 65
087.9853.07		2 x (H - 160)
180.9630.07		2B + 4H
Lock set		1
Wheels set		1
162.7930.--		min. 1
162.8035.04		1
052.5309.--		2
162.9060.SY		1
162.9061.04		1
162.8081.04		2
162.8065.04		1
162.9310.04		2
180.9160.04		B
180.9410.04		2B1
180.9412.04		2B1 + 4H
180.9414.04		2B1
180.9416.04		2B1 + 2H
180.9493.04		1
062.7715.XX		34G.F
069.6830.04		34G.F

\* KNIP IN STUKKEN  
 \* COUPE EN MORCEAUX  
 \* CUT IN PIECES  
 \* IN STUCKE SCHNEIDEN



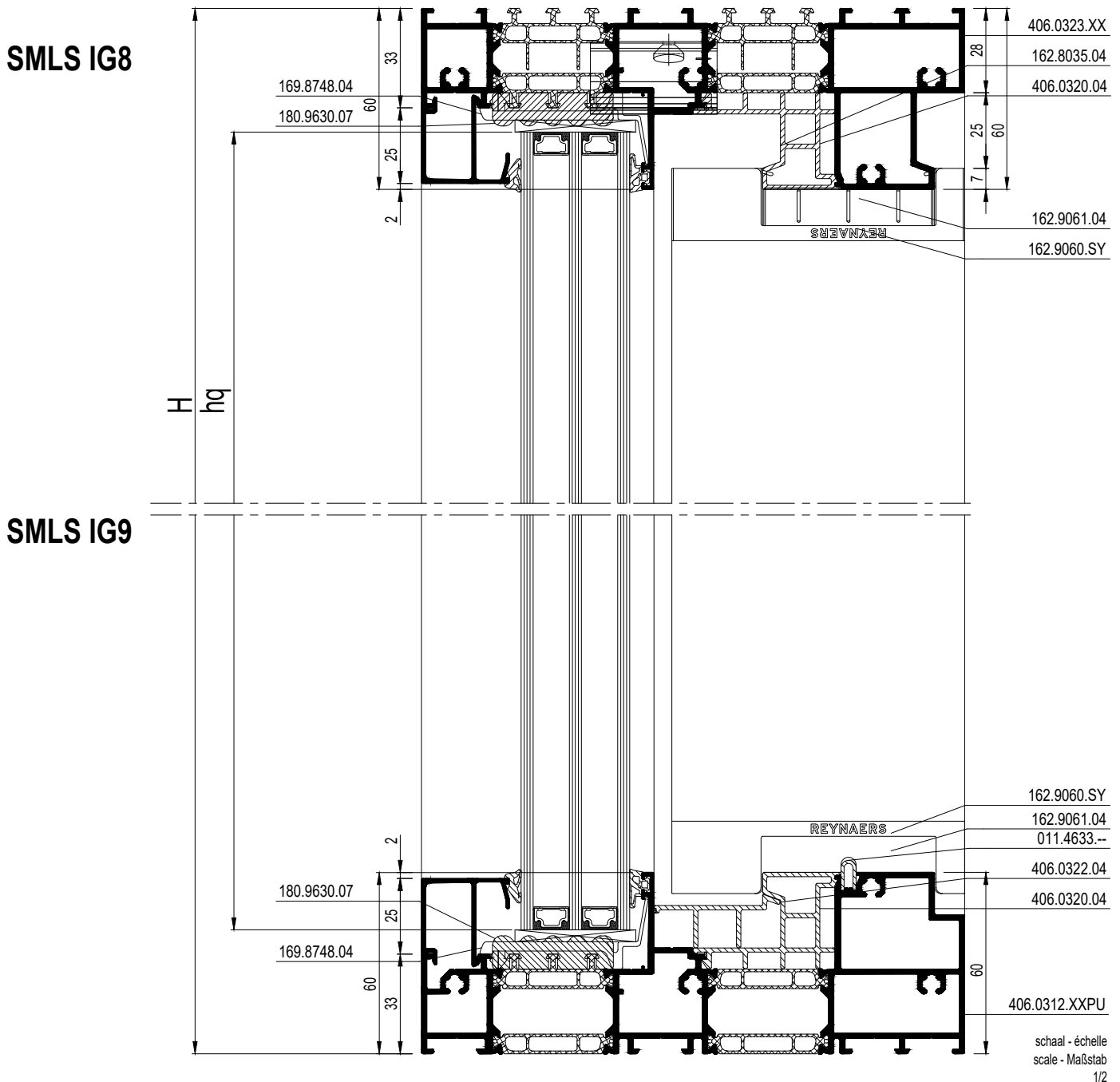
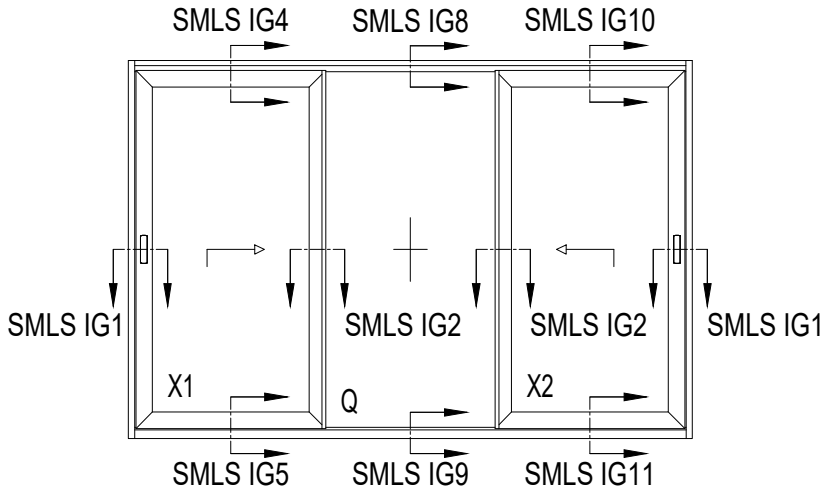

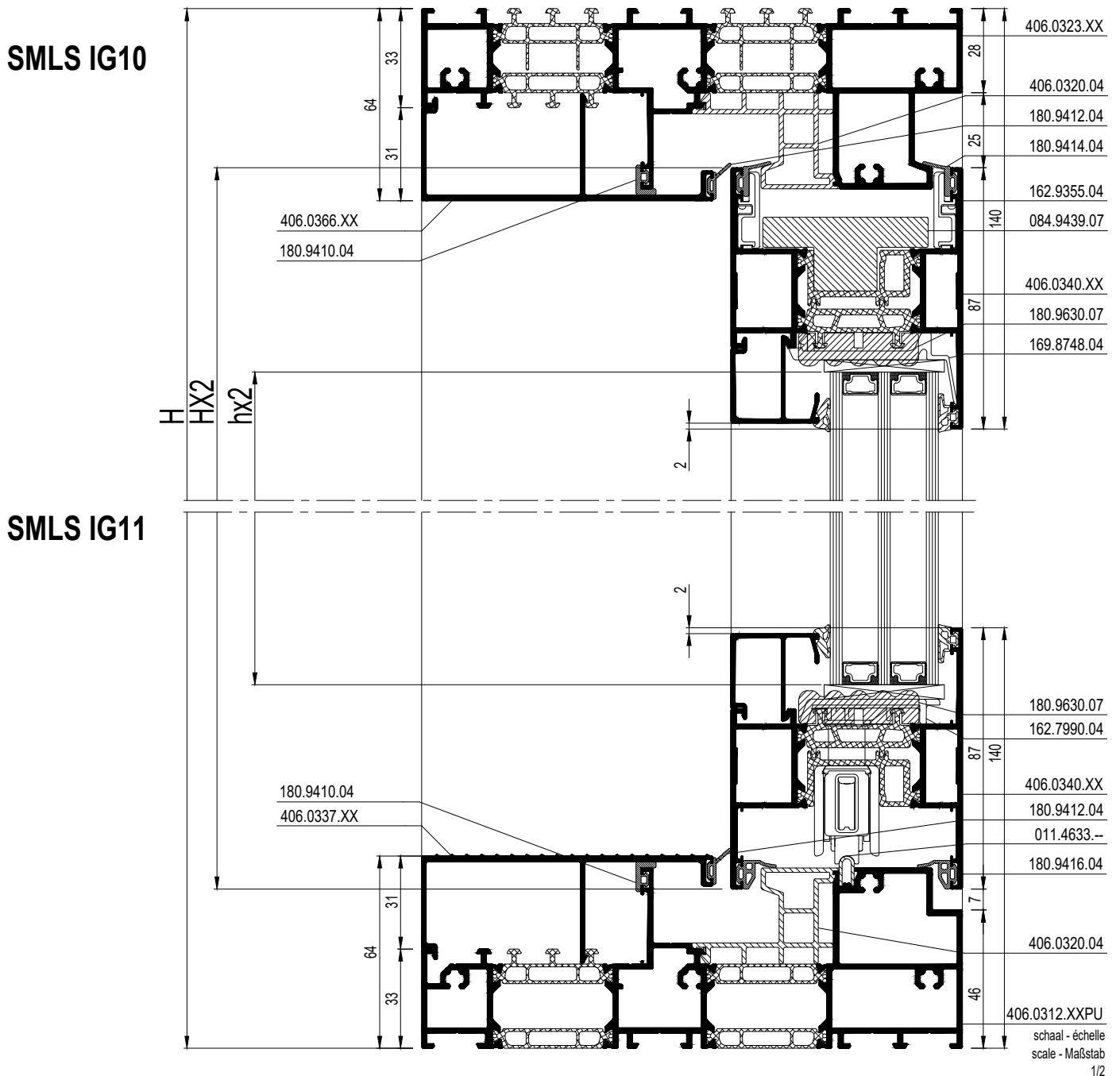

			#	$\leftarrow L_m \rightarrow$
406.0312.XXPU			1	B-66
406.0323.XX			1	B-66
406.0325.XX			2	H
406.0322.04			1	B2 - 86
406.0320.04			2	B - 66
011.4633.--			1	B - 94
406.0326.04			2	H - 120
406.0324.04			2	H - 120 *
406.0337.XX			2	B1 - 77
			2	B3 - 77
406.0340.XX			2	H - 106
			2	B1 + 3.5 (-20)
			2	B3 + 3.5 (-20)
406.0343.04			2	H - 176
030.3613.XX			4	H - 276
			2	B1 - 116.5
			2	H - 116
			2	B2 - 33
			2	B3 - 116.5
406.0335.XX			2	H-146
			2	H-66
406.0341.04			4	H - 106
406.0342.XX			2	H-154
			2	H-66
0M0.1505.00			2	34G.F

	BX1 = B1+3.5
	BQ = B2+87
	BX2 = B3+3.5
	HX = H-106
	bx1 = BX1-136
	bq = BQ-136
	bx3 = BX3-136
	hx = HX-136
	hq = H-82

		#
052.5371.--		16
168.8932.00		4
168.8748.00		4
168.5012.--		4
168.8688.04		4
168.8105.00		8
168.5012.--		8
168.8106.00		8
050.5091.--		16
160.8725.--		8
160.8750.--		12
052.5300.--		4 x (H / 300)
162.7980.04		10
162.7990.04		5
169.8748.04		16
162.9355.04		12
080.9124.SY		2B + 6H
080.9381.04		4H
180.9114.SY		2B + 6H
080.9738.04		2
		2 x (H - 159)
084.9440.07		2 x (H - 66)
084.9439.07		B1 - 65
		B3 - 65
087.9853.07		4 x (H - 160)
180.9630.07		2B + 6H
Lock set		2
Wheels set		2
162.7930.--		min. 2
162.8035.04		2
052.5309.--		4
162.9060.SY		2
162.9061.04		2
162.8081.04		4
162.8064.04		1
162.8065.04		1
162.9310.04		2
180.9160.04		B
180.9410.04		2B1 + 2B3
180.9412.04		2B1+2B3+8H
180.9414.04		2B1 + 2B3
180.9416.04		2B1+2B3+4H
180.9493.04		2
062.7715.XX		34G.F
069.6830.04		34G.F

\* KNIP IN STUKKEN  
 \* COUPE EN MORCEAUX  
 \* CUT IN PIECES  
 \* IN STÜCKE SCHNEIDEN



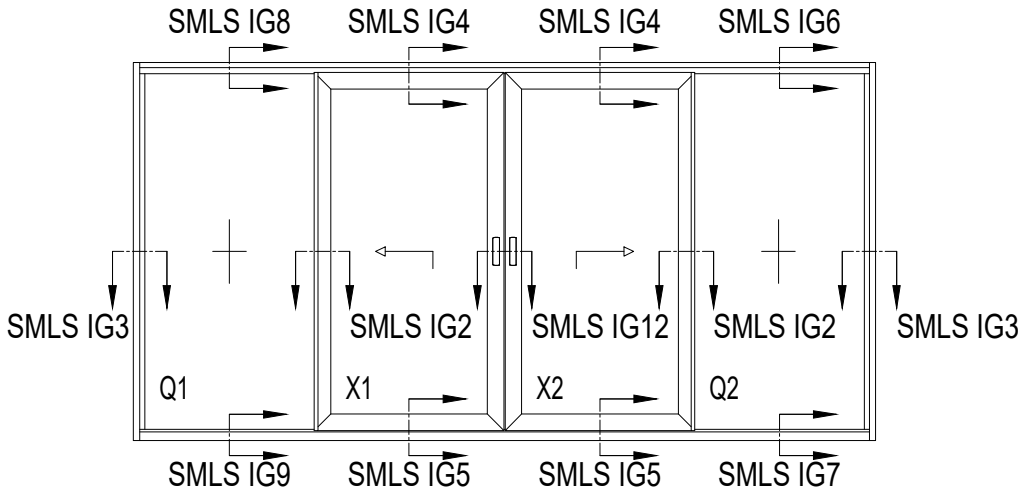

SMLS IG12

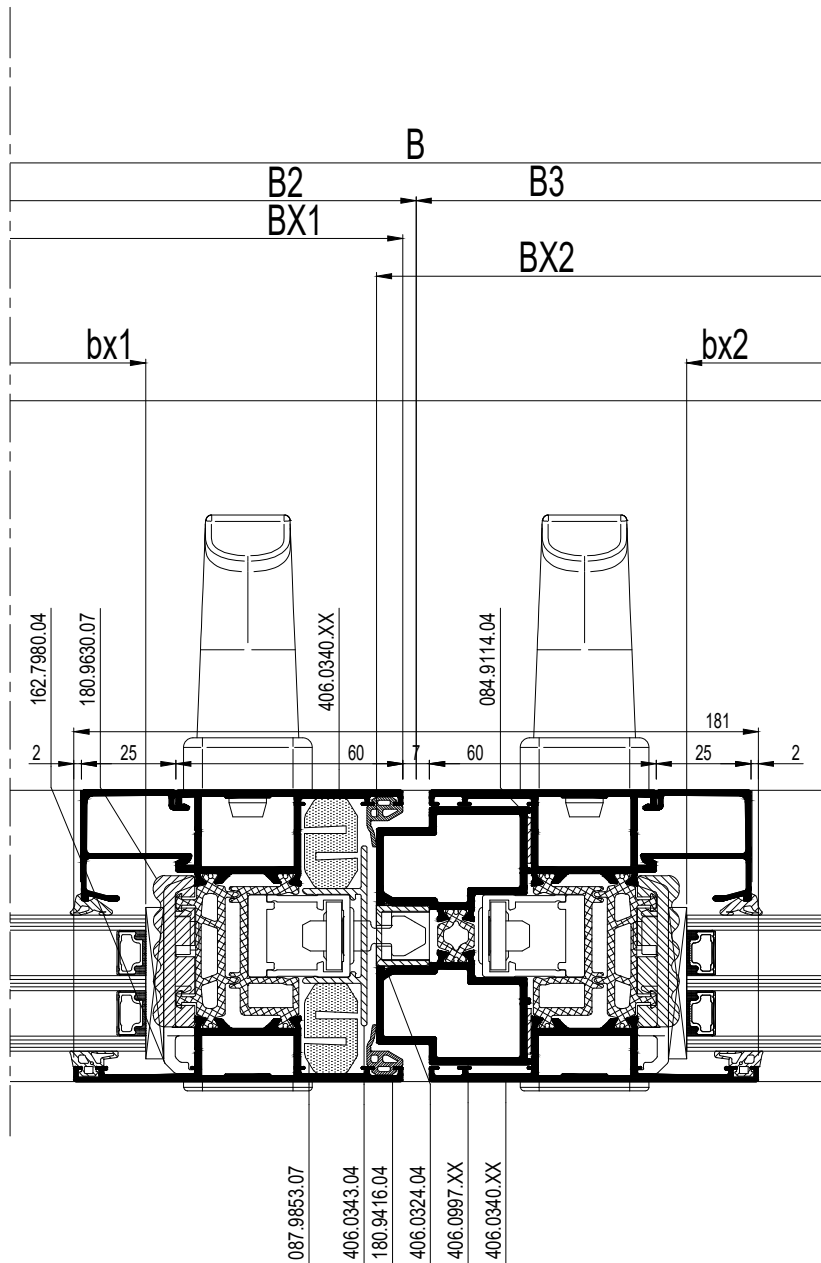

schaal - échelle  
 scale - Maßstab  
 1/2

			#	$\leftarrow L_m \rightarrow$
406.0312.XXPU			1	B-66
406.0323.XX			1	B-66
406.0327.XX			2	H
406.0322.04			1	B1 - 78.5
			1	B4 - 78.5
406.0320.04			2	B - 66
011.4633.--			1	(B1+B2) - 9.5
			1	(B3+B4) - 89.5
406.0324.04			1	H - 188 *
406.0337.XX			2	(B2+B3) - 87.5
406.0340.XX			2	H - 106
			2	B2 + 40 (-20)
			2	B3 + 40 (-20)
406.0343.04			1	H - 176
030.3613.XX			4	H - 276
			2	B1 - 49.5
			4	H - 116
			2	B2 - 80
			2	B3 - 80
			2	B4 - 49.5
406.0335.XX			2	H-146
			2	H-66
406.0341.04			4	H - 106
406.0342.XX			2	H-154
			2	H-66
406.0997.XX			1	H - 192
0M0.1505.00			2	34G.F

\* KNIP IN STUKKEN  
 \* COUPE EN MORCEAUX  
 \* CUT IN PIECES  
 \* IN STUCKE SCHNEIDEN

\*\* VOOR SECUNDAIRE VLEUGEL  
 \*\* POUR SEMI-FIXE  
 \*\* FOR SECOND VENT  
 \*\* FÜR STANDFLÜGEL

	BQ1 = B1+43.5
	BX1 = B2+40
	BX2 = B3+54
	BQ2 = B4+43.5
	HX = H-106
	bq1 = BQ1-109
	bx1 = BX1-136
	bx2 = BX2-150
	bq2 = BQ2-109
	hq = H-82
	hx = HX-136

		#
052.5371.--		16
168.8688.04		8
168.8932.00		4
168.8748.00		4
168.5012.--		4
168.8675.04		4
168.8105.00		8
168.5012.--		8
168.8106.00		8
050.5091.--		16
160.8725.--		8
160.8750.--		16
052.5300.--		4 x (H / 300)
050.5074.--		34G.F
162.7980.04		10
162.7990.04		5
169.8748.04		24
162.9355.04		12
080.9124.SY		2B + 8H
080.9381.04		4H
180.9114.SY		2B + 8H
084.9114.04		2H
080.9738.04		2
084.9440.07		2 x (H - 159) 2 x (H - 66)
084.9439.07		B2 - 28.5 B3 - 28.5
087.9853.07		2 x (H - 160)
180.9630.07		2B + 8H
Lock set		1
Lock set		1 **
Wheels set		2
162.7930.--		min. 1
162.7940.--		1
162.8035.04		2
052.5309.--		4
162.9060.SY		2
162.9061.04		2
162.8064.04		1
162.8065.04		1
162.9310.04		2
180.9160.04		B
180.9410.04		2B2 + 2B3
180.9412.04		2B2+2B3+8H
180.9414.04		2B2 + 2B3
180.9416.04		2B2+2B3+2H
180.8120.04		1
180.9493.04		1
069.6830.04		34G.F
062.7715.XX		34G.F

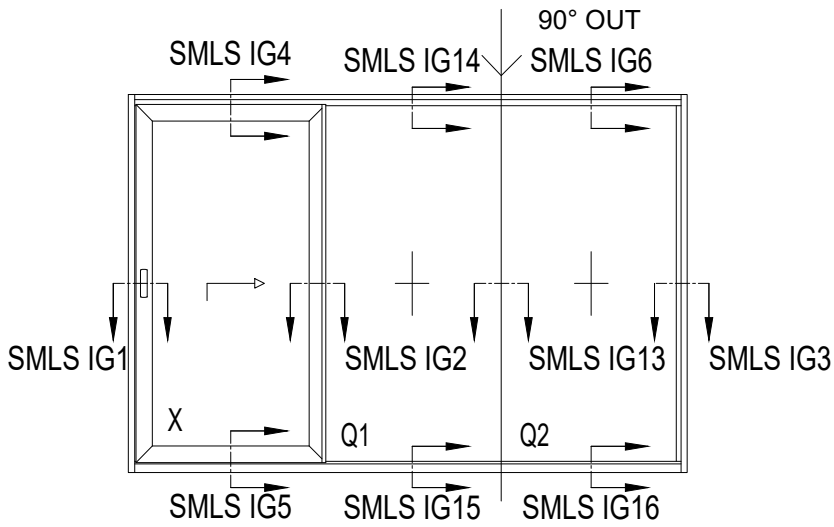

**SMLS IG13**

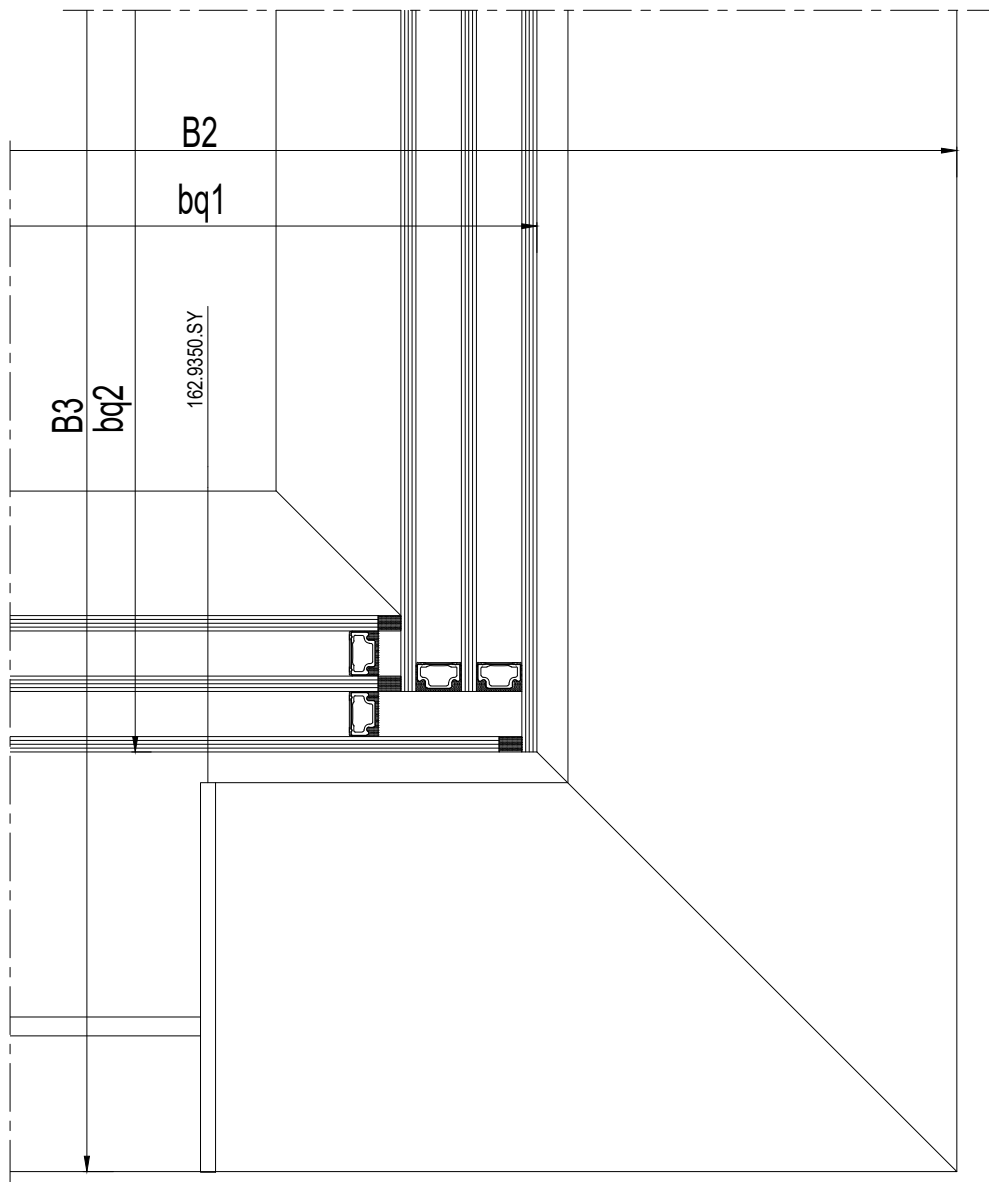

schaal - échelle  
 scale - Maßstab  
 1/2

**SMLS IG14**

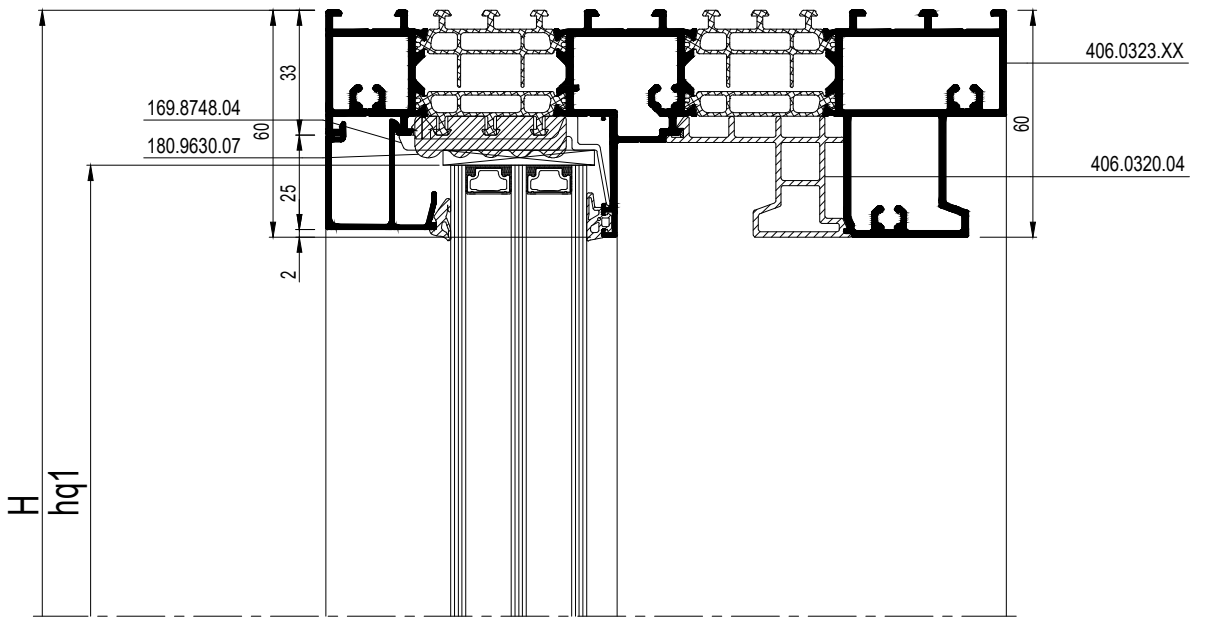

**SMLS IG15**

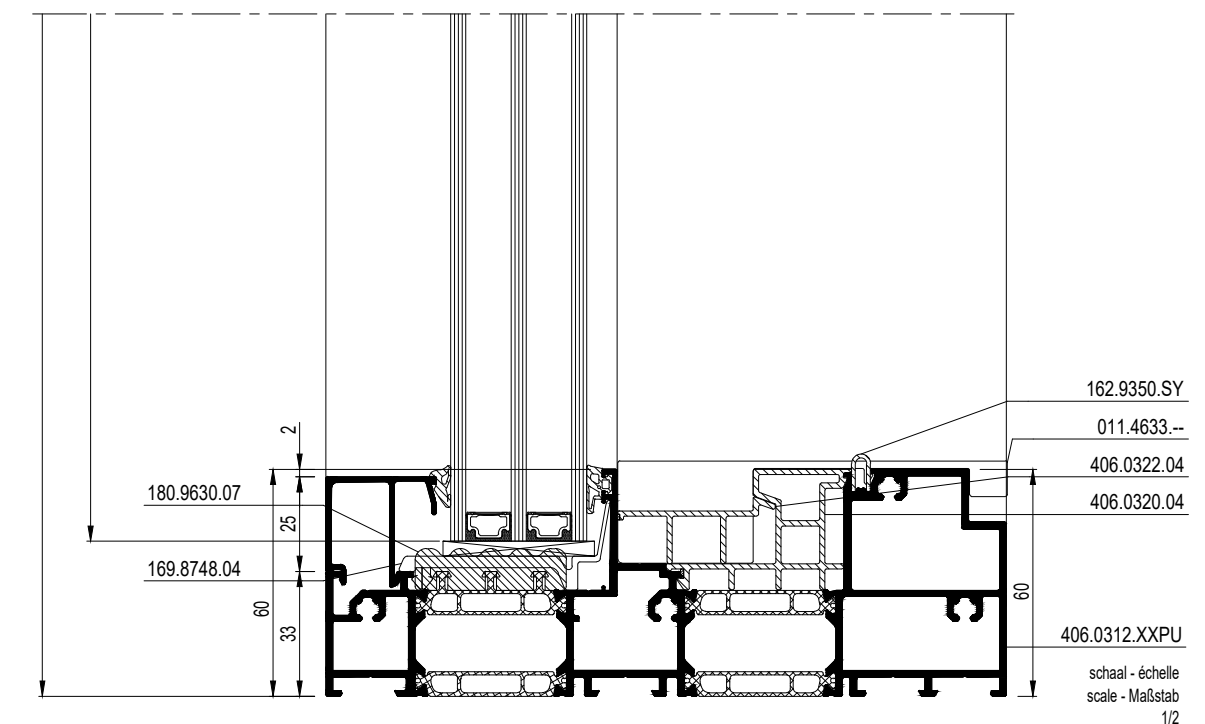

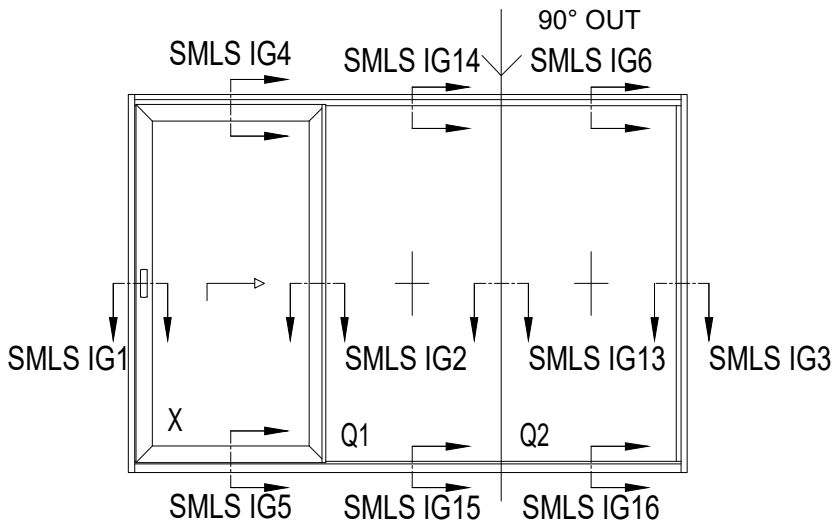



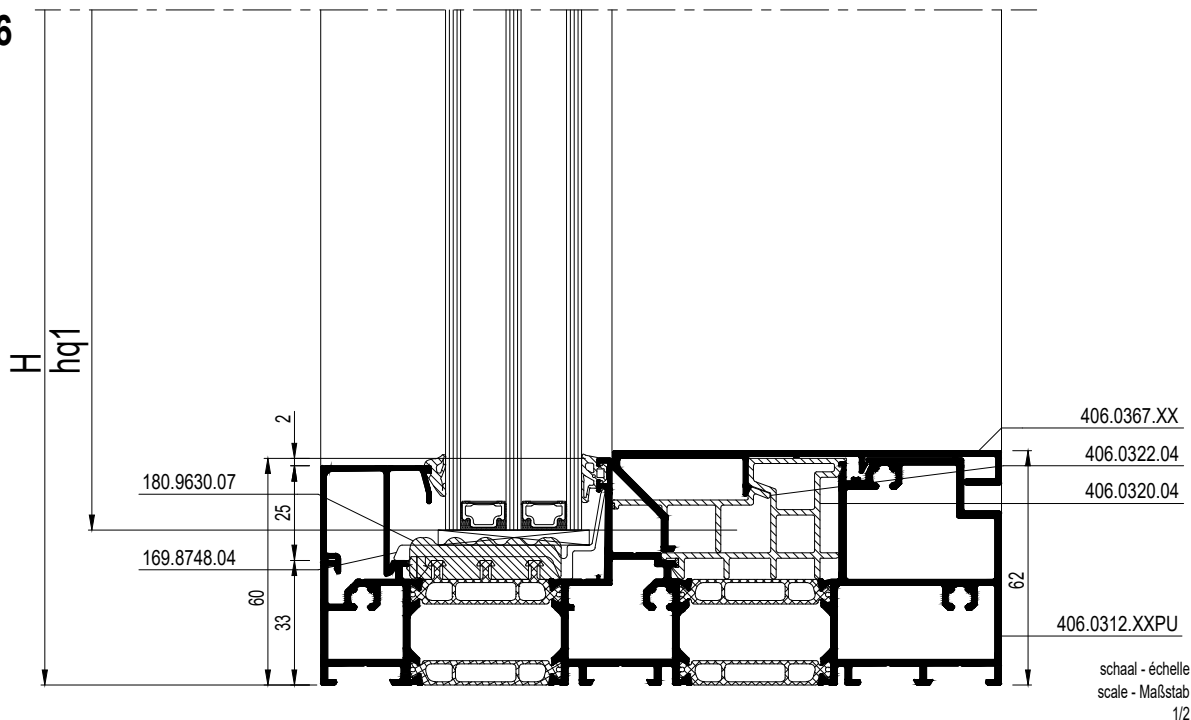





































**SMLS IG16**





















			#	$\leftarrow L_m \rightarrow$	
406.0312.XXPU			1	(B1 + B2) - 33	BX = B1+3.5 HX = H-106 bx = BX-136 bq1 = B2-135.5 bq2 = B3-152 hx = HX-136 hq = H-82
			1	B3 - 33	
406.0323.XX			1	(B1 + B2) - 33	
			1	B3 - 33	
406.0325.XX			1	H	
406.0327.XX			1	H	
406.0322.04			1	B1 - 23.5	
406.0320.04			1	(B1 + B2) - 74	
			1	B3 - 74	
			1	B3 - 74	
			1	(B1 + B2) - 74	
011.4633.--			1	2B1+22	
406.0326.04			1	H - 120	
406.0324.04			1	H - 120 *	
406.0337.XX			2	B1 - 77	
406.0367.XX			1	B3 - 33.5	
			1	B2-B1-26	
406.0340.XX			1	H - 106	
			1	B1 + 3.5 (-20)	
			1	B1 + 3.5 (-20)	
406.0343.04			1	H - 176	
030.3613.XX			2	H - 276	
			2	B1 - 116.5	
			2	H - 116	
			1	B2 - 170.5	
			1	B3 - 187	
			1	B3 - 187	
			1	B2 - 170.5	
406.0335.XX			1	H - 146	
			1	H - 66	
406.0341.04			2	H - 106	
406.0342.XX			1	H - 154	
			1	H - 66	
0M0.1505.00			1	 34G.F	

\* KNIP IN STUKKEN  
 \* COUPE EN MORCEAUX  
 \* CUT IN PIECES  
 \* IN STUCKE SCHNEIDEN

		#
052.5371.--		16
168.8688.04		4
162.8050.00		4
050.5094.--		16
054.5441.04		16
162.8051.00		2
050.5094.--		16
054.5441.04		16
168.8932.00		2
168.8748.00		2
168.5012.--		2
168.8675.04		2
168.8105.00		4
168.5012.--		4
168.8106.00		4
050.5091.--		8
160.8725.--		4
160.8750.--		8
160.8745.00		2
052.5300.--		2 x (H / 300)
162.7980.04		5
162.7990.04		3
169.8748.04		16
162.9355.04		6
080.9124.SY		2B + 4H
080.9381.04		2H
180.9114.SY		2B + 4H
080.9738.04		2
084.9440.07		H - 159 H - 66
084.9439.07		B1 - 65
087.9853.07		2 x (H - 160)
180.9630.07		2B + 4H
Lock set		1
Wheels set		1
162.7930.--		min. 1
162.8035.04		1
052.5309.--		2
162.9060.SY		1
162.9061.04		1



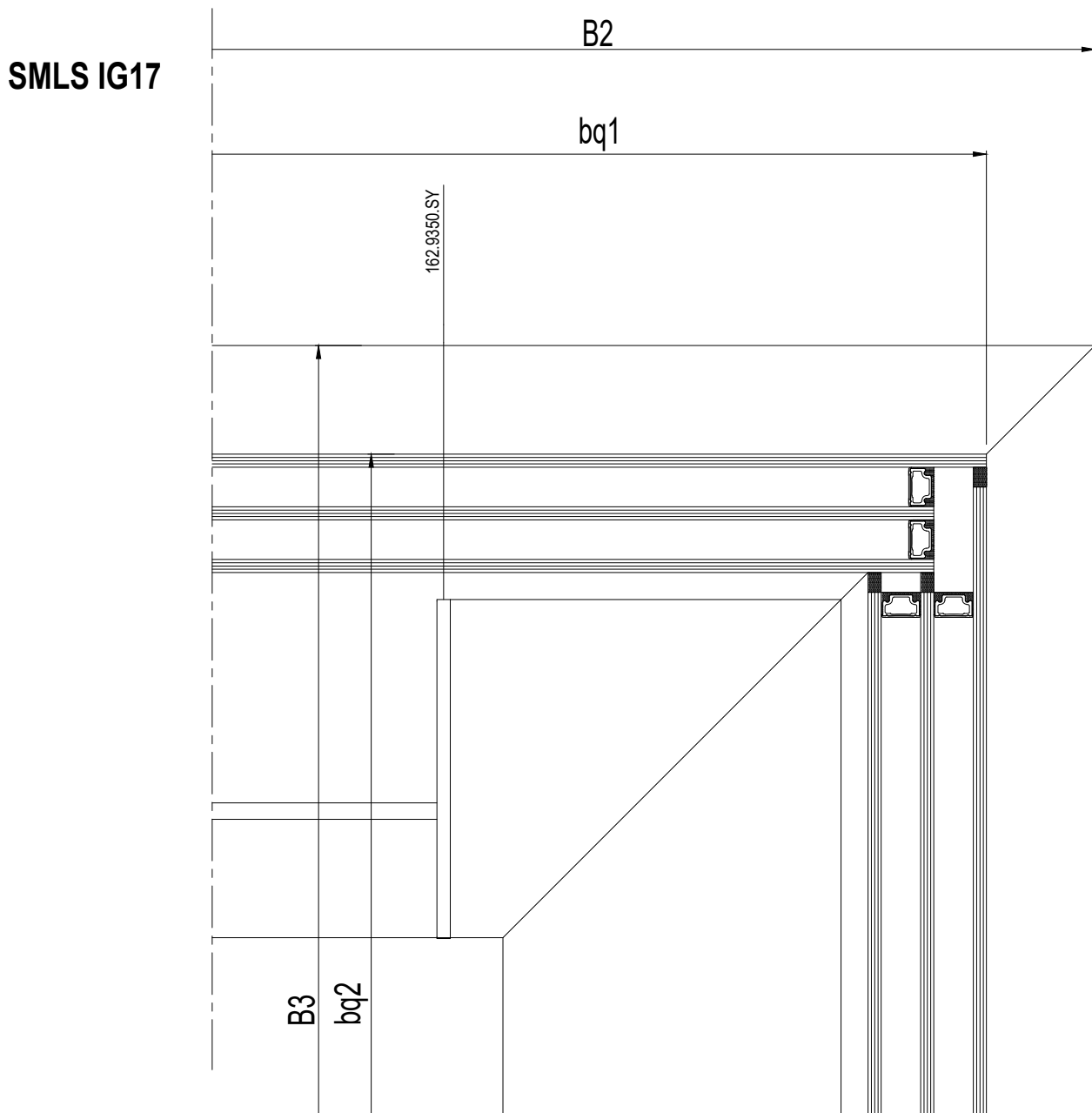
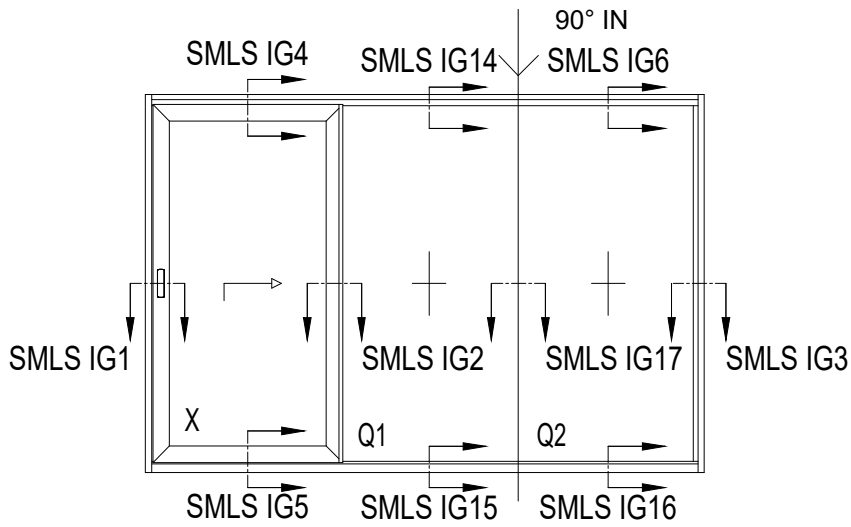





















































		#
162.8081.04		2
162.8065.04		1
162.9360.SY		1
162.9310.04		4
180.9160.04		2B1 - 22
180.9410.04		2B1
180.9412.04		2B1 + 4H
180.9414.04		2B1
180.9416.04		2B1 + 2H
180.9493.04		1
062.7715.XX		 34G.F
069.6830.04		 34G.F











































schaal - échelle  
 scale - Maßstab  
 1/2



















E

			#	$\leftarrow L_m \rightarrow$	
406.0312.XXPU			1	(B1 + B2) - 33	BX = B1+3.5 HX = H-106 bx = BX-136 bq1 = B2-57.5 bq2 = B3-74 hx = HX-136 hq = H-82
			1	B3 - 33	
406.0323.XX			1	(B1 + B2) - 33	
			1	B3 - 33	
406.0325.XX			1	H	
406.0327.XX			1	H	
406.0322.04			1	B1-23.5	
406.0320.04			1	(B1 + B2) - 123	
			1	B3 - 123	
			1	B3 - 123	
			1	(B1 + B2) - 123	
011.4633.--			1	2B1+22	
406.0326.04			1	H - 120	
406.0324.04			1	H - 120 *	
406.0337.XX			2	B1 - 77	
406.0367.XX			1	B3 - 110.5	
			1	B2-B1-103	
406.0340.XX			1	H - 106	
			1	B1 + 3.5 (-20)	
			1	B1 + 3.5 (-20)	
406.0343.04			1	H - 176	
030.3613.XX			2	H - 276	
			2	B1 - 116.5	
			2	H - 116	
			1	B2 - 16.5	
			1	B3 - 33	
			1	B3 - 33	
			1	B2 - 16.5	
406.0335.XX			1	H - 146	
			1	H - 66	
406.0341.04			2	H - 106	
406.0342.XX			1	H - 154	
			1	H - 66	
OM0.1505.00			1	 34G.F	

\* KNIP IN STUKKEN  
 \* COUPE EN MORCEAUX  
 \* CUT IN PIECES  
 \* IN STUCKE SCHNEIDEN

		#
052.5371.--		16
168.8688.04		4
162.8050.00		4
050.5094.--		16
054.5441.04		16
162.8051.00		2
050.5094.--		16
054.5441.04		16
168.8932.00		2
168.8748.00		2
168.5012.--		2
168.8675.04		2
168.8105.00		4
168.5012.--		4
168.8106.00		4
050.5091.--		8
160.8725.--		4
160.8750.--		8
160.8745.00		2
052.5300.--		2 x (H / 300)
162.7980.04		5
162.7990.04		3
169.8748.04		16
162.9355.04		6
080.9124.SY		2B + 4H
080.9381.04		2H
180.9114.SY		2B + 4H
080.9738.04		2
084.9440.07		H - 159 H - 66
084.9439.07		B1 - 65
087.9853.07		2 x (H - 160)
180.9630.07		2B + 4H
Lock set		1
Wheels set		1
162.7930.--		min. 1
162.8035.04		1
052.5309.--		2
162.9060.SY		1
162.9061.04		1

		#
162.8081.04		2
162.8065.04		1
162.9360.SY		1
162.9310.04		4
180.9160.04		2B1+22
180.9410.04		2B1
180.9412.04		2B1 + 4H
180.9414.04		2B1
180.9416.04		2B1 + 2H
180.9493.04		1
062.7715.XX		 34G.F
069.6830.04		 34G.F

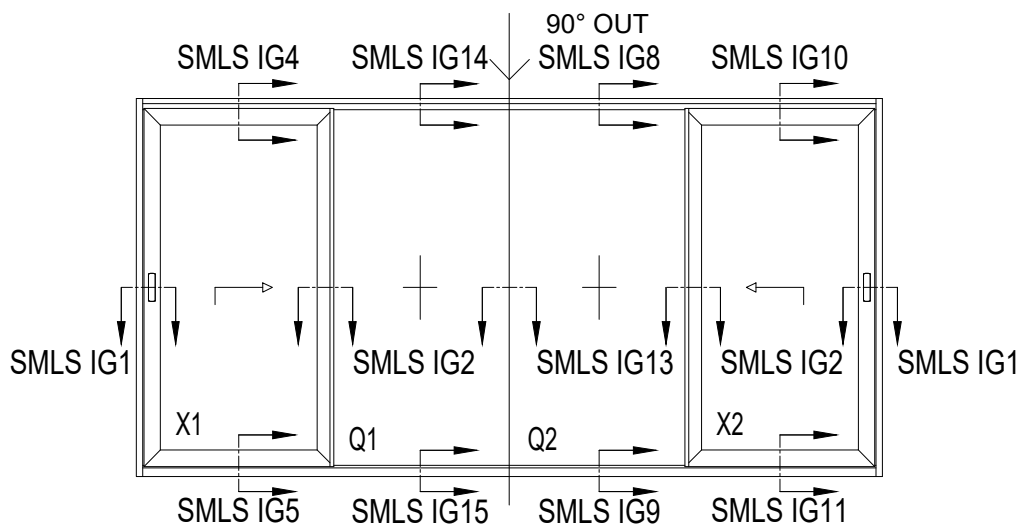

























































BX1 = B1+3.5
BX2 = B4+3.5
HX = H-106
bx1 = BX1-136
bq1 = B2-135.5
bq2 = B3-135.5
bx2 = BX2-136
hx = HX-136
hq = H-82

			#	$\leftarrow L_m$
406.0312.XXPU			1	(B1 + B2) - 33
			1	(B3 + B4) - 33
406.0323.XX			1	(B1 + B2) - 33
			1	(B3 + B4) - 33
406.0325.XX			2	H
406.0322.04			1	B2 - 107
			1	B3 - 107
406.0320.04			1	(B1 + B2) - 74
			1	(B3 + B4) - 74
			1	(B3 + B4) - 74
			1	(B1 + B2) - 74
011.4633.--			1	(B1 + B2) - 83
			1	(B3 + B4) - 83
406.0326.04			2	H - 120
406.0324.04			2	H - 120 *
406.0337.XX			2	B1 - 77
			2	B4 - 77
406.0340.XX			4	H - 106
			1	B1 + 3.5 (-20)
			1	B1 + 3.5 (-20)
			1	B4 + 3.5 (-20)

			#	$\leftarrow L_m$
406.0343.04			2	H - 176
030.3613.XX			4	H - 276
			2	B1 - 116.5
			2	H - 116
			1	B2 - 170.5
			1	B2 - 170.5
			1	B3 - 170.5
406.0335.XX			2	H - 146
			2	H - 66
406.0341.04			4	H - 106
406.0342.XX			2	H - 154
			2	H - 66
0M0.1505.00			2	34G.F

\* KNIP IN STUKKEN  
 \* COUPE EN MORCEAUX  
 \* CUT IN PIECES  
 \* IN STUCKE SCHNEIDEN

		#
052.5371.--		16
162.8050.00		4
050.5094.--		16
054.5441.04		16
162.8051.00		2
050.5094.--		16
054.5441.04		16
168.8932.00		4
168.8748.00		4
168.5012.--		4
168.8688.04		8
168.8105.00		8
168.5012.--		8
168.8106.00		8
050.5091.--		16
160.8725.--		8
160.8750.--		12
160.8745.00		2
052.5300.--		4 x (H / 300)
162.7980.04		10
162.7990.04		5
169.8748.04		20
162.9355.04		12
080.9124.SY		2B + 6H
080.9381.04		4H
180.9114.SY		2B + 6H
080.9738.04		2
084.9440.07		2 x (H - 159) 2 x (H - 66)
084.9439.07		B1 - 65 B4 - 65
087.9853.07		4 x (H - 160)
180.9630.07		2B + 6H
Lock set		2
Wheels set		2
162.7930.--		min. 2
162.8035.04		2
052.5309.--		4
162.9060.SY		2
162.9061.04		2

		#
162.8081.04		4
162.8064.04		1
162.8065.04		1
162.9310.04		4
180.9160.04		B
180.9410.04		2B1 + 2B4
180.9412.04		2B1+2B4+8H
180.9414.04		2B1 + 2B4
180.9416.04		2B1+2B4+4H
180.9493.04		2
062.7715.XX		 34G.F
069.6830.04		 34G.F

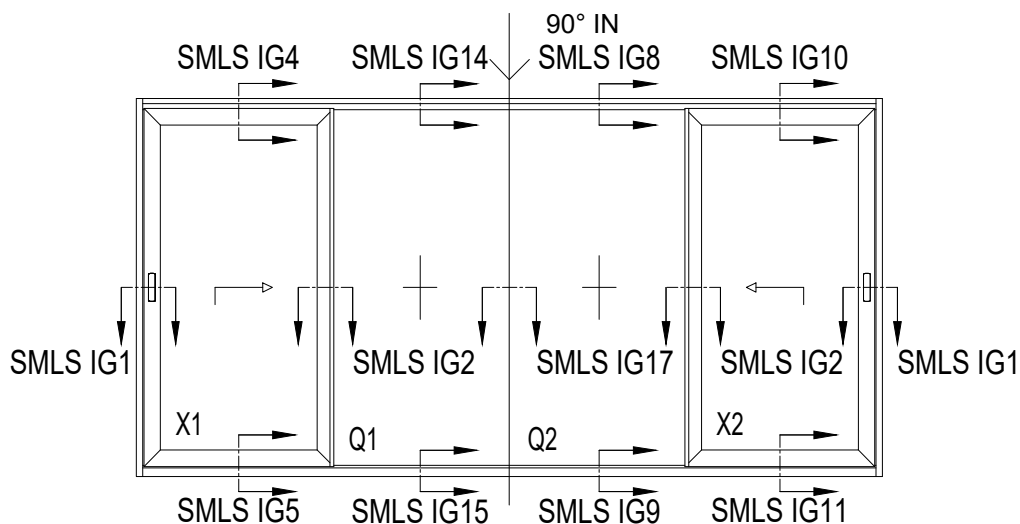

























































BX1 = B1+3.5
BX2 = B4+3.5
HX = H-106
bx1 = BX1-136
bq1 = B2-57.5
bq2 = B3-57.5
bx2 = BX2-136
hx = HX-136
hq = H-82

			#	$\leftarrow L_m \rightarrow$
406.0312.XXPU			1	(B1 + B2) - 33
			1	(B3 + B4) - 33
406.0323.XX			1	(B1 + B2) - 33
			1	(B3 + B4) - 33
406.0325.XX			2	H
406.0322.04			1	B2 - 122.5
			1	B3 - 122.5
406.0320.04			1	(B1 + B2) - 123
			1	(B3 + B4) - 123
			1	(B3 + B4) - 123
			1	(B1 + B2) - 123
011.4633.--			1	(B1 + B2) - 186
			1	(B3 + B4) - 186
406.0326.04			2	H - 120
406.0324.04			2	H - 120 *
406.0337.XX			2	B1 - 77
			2	B4 - 77
406.0340.XX			4	H - 106
			1	B1 + 3.5 (-20)
			1	B1 + 3.5 (-20)
			1	B4 + 3.5 (-20)

			#	$\leftarrow L_m \rightarrow$
406.0343.04			2	H - 176
030.3613.XX			4	H - 276
			2	B1 - 116.5
			2	H - 116
			1	B2 - 16.5
			1	B2 - 16.5
			1	B3 - 16.5
406.0335.XX			2	H - 146
			2	H - 66
406.0341.04			4	H - 106
406.0342.XX			2	H - 154
			2	H - 66
0M0.1505.00			2	34G.F

\* KNIP IN STUKKEN  
 \* COUPE EN MORCEAUX  
 \* CUT IN PIECES  
 \* IN STUCKE SCHNEIDEN

		#
052.5371.--		16
162.8050.00		4
050.5094.--		16
054.5441.04		16
162.8051.00		2
050.5094.--		16
054.5441.04		16
168.8932.00		4
168.8748.00		4
168.5012.--		4
168.8688.04		8
168.8105.00		8
168.5012.--		8
168.8106.00		8
050.5091.--		16
160.8725.--		8
160.8750.--		12
160.8745.00		2
052.5300.--		4 x (H / 300)
162.7980.04		10
162.7990.04		5
169.8748.04		20
162.9355.04		12
080.9124.SY		2B + 6H
080.9381.04		4H
180.9114.SY		2B + 6H
080.9738.04		2
084.9440.07		2 x (H - 159) 2 x (H - 66)
084.9439.07		B1 - 65 B4 - 65
087.9853.07		4 x (H - 160)
180.9630.07		2B + 6H
Lock set		2
Wheels set		2
162.7930.--		min. 2
162.8035.04		2
052.5309.--		4
162.9060.SY		2
162.9061.04		2

		#
162.8081.04		4
162.8064.04		1
162.8065.04		1
162.9310.04		4
180.9160.04		B
180.9410.04		2B1 + 2B4
180.9412.04		2B1+2B4+8H
180.9414.04		2B1 + 2B4
180.9416.04		2B1+2B4+4H
180.9493.04		2
062.7715.XX		 34G.F
069.6830.04		 34G.F

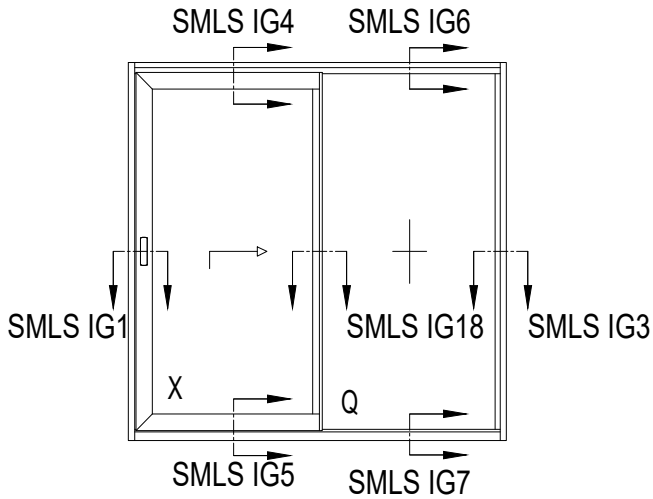

**SMLS IG18**

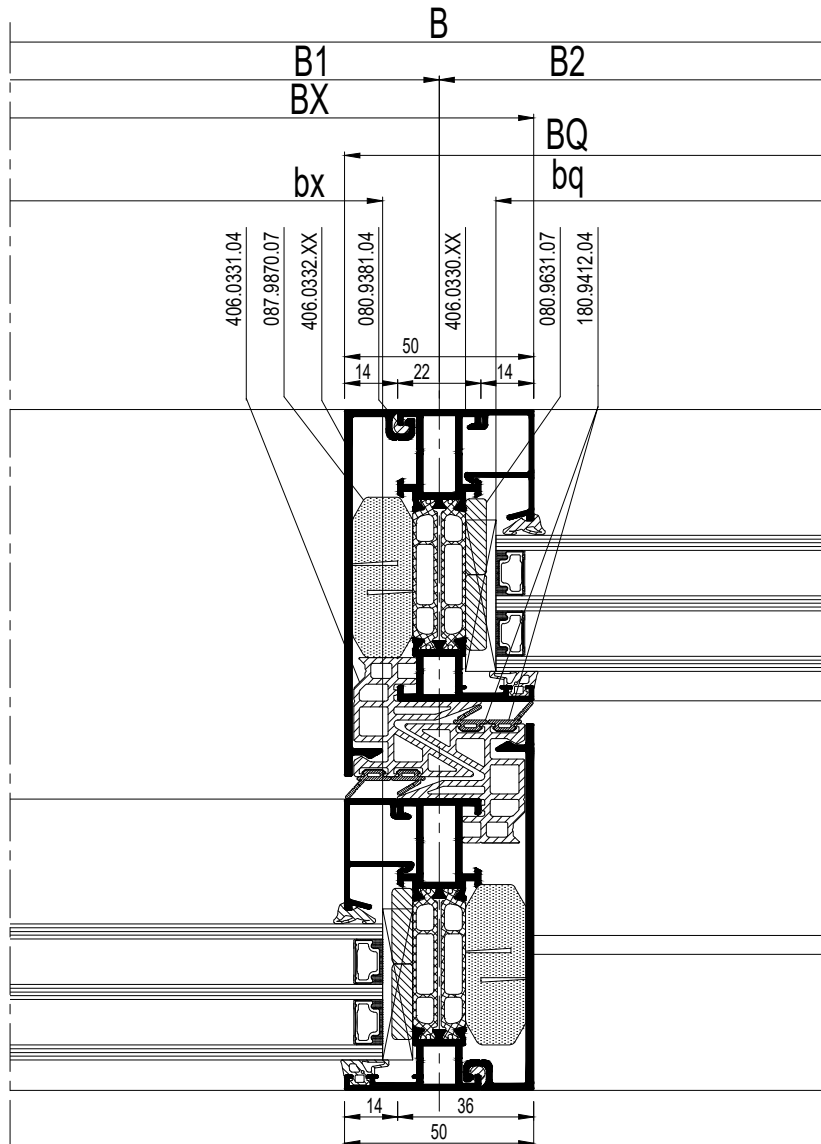

schaal - échelle  
 scale - Maßstab  
 1/2

			#	$\leftarrow L_m \rightarrow$
406.0312.XXPU			1	B-66
406.0323.XX			1	B-66
406.0325.XX			1	H
406.0327.XX			1	H
406.0322.04			1	B2 - 60
406.0320.04			2	B - 66
011.4633.--			1	B - 80
406.0326.04			1	H - 120
406.0324.04			1	H - 120 *
406.0337.XX			2	B1 - 58.5
406.0340.XX			1	H - 106
			1	B1 - 29
			1	B1 - 29
406.0343.04			1	H - 176
030.3613.XX			1	H - 276
			2	B1 - 111
			2	B2 - 44
			1	H - 116
002.0687.XX			1	H - 276
			1	H - 116
406.0330.XX			1	H - 226
			1	H - 66
406.0331.04			2	H - 106
406.0332.XX			1	H - 154
			1	H - 66
0M0.1505.00			1	34G.F

\* KNIP IN STUKKEN  
 \* COUPE EN MORCEAUX  
 \* CUT IN PIECES  
 \* IN STUCKE SCHNEIDEN

	BX = B1-15
	BQ = B2+25
	HX = H-106
	bx = BX-108
	bq = BQ-81
	hx = HX-136
	hq = H-82

		#
052.5371.--		16
068.8932.00		4
168.8725.00		2
168.5012.--		1
168.8727.00		2
050.5083.--		2
168.5012.--		1
168.8675.04		2
168.8688.04		4
168.8105.00		2
168.5012.--		2
168.8106.00		2
050.5091.--		4
160.8725.--		4
160.8750.--		4
052.5327.--		2 x (H / 300)
162.7980.04		5
162.7990.04		3
169.8748.04		8
162.9355.04		6
080.9124.SY		2B + 4H
080.9381.04		2H
180.9114.SY		2B + 4H
080.9738.04		2
087.9870.07		H - 159
		H - 66
084.9439.07		B1 - 60.5
087.9853.07		2 x (H - 160)
180.9630.07		2B + 2H
080.9631.07		4H
Lock set		1
Wheels set		1
162.7930.--		min. 1
162.8035.04		1
052.5309.--		2
162.9090.SY		1
162.9091.04		1
162.8081.04		2
162.8075.04		1
162.9310.04		2
180.9160.04		B
180.9410.04		2B1
180.9412.04		2B1 + 4H
180.9414.04		2B1
180.9416.04		2B1 + 2H
180.9493.04		1
062.7715.XX		34G.F
069.6830.04		34G.F

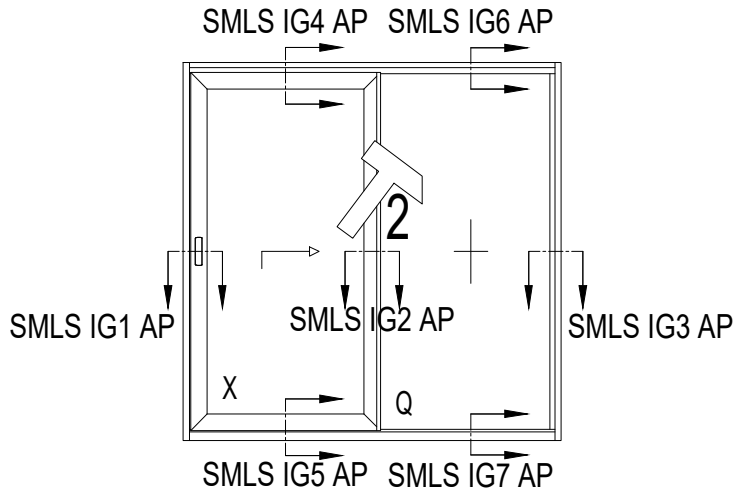

## SMLS IG1 AP

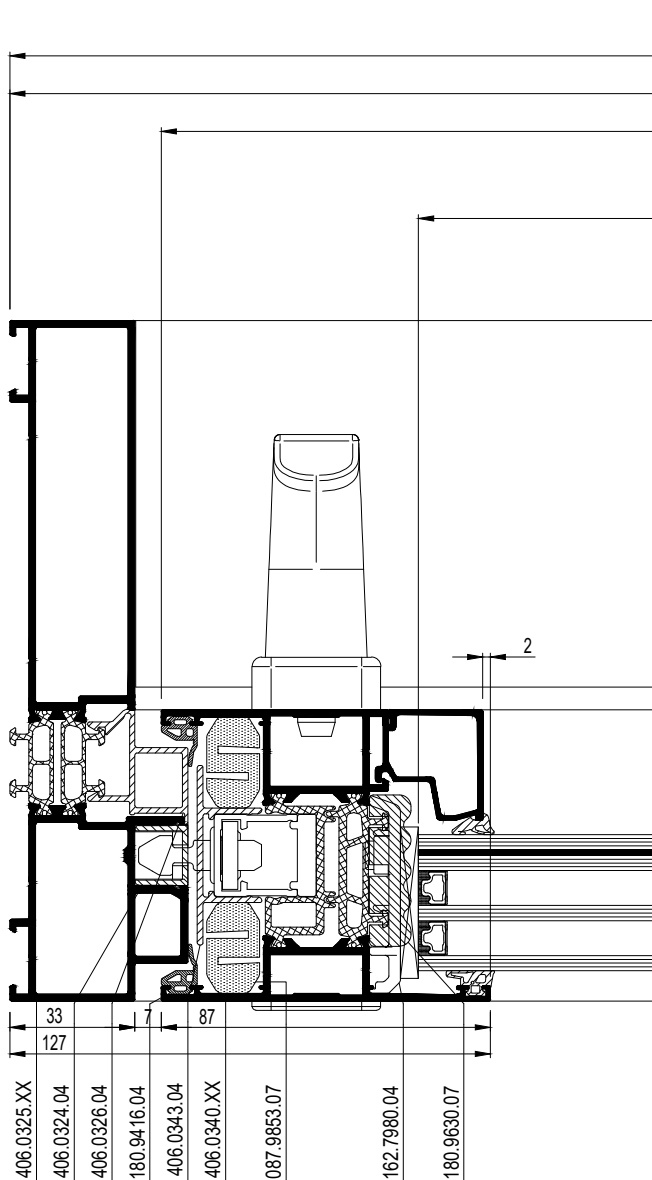

## SMLS IG2 AP

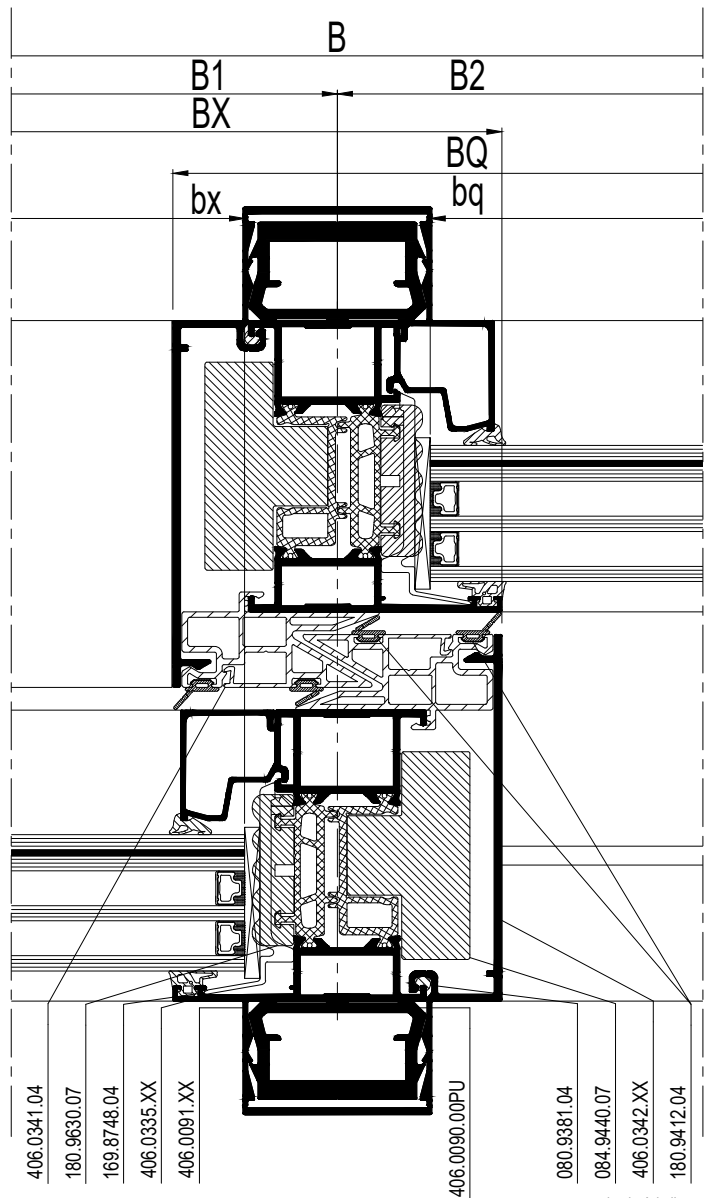

schaal - échelle  
 scale - Maßstab  
 1/2

## SMLS IG3 AP

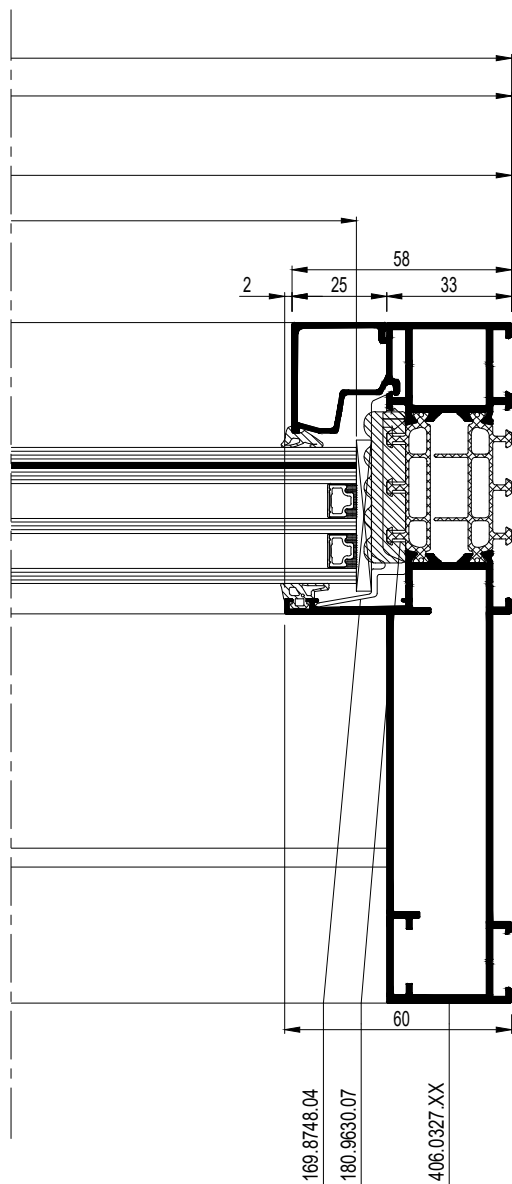

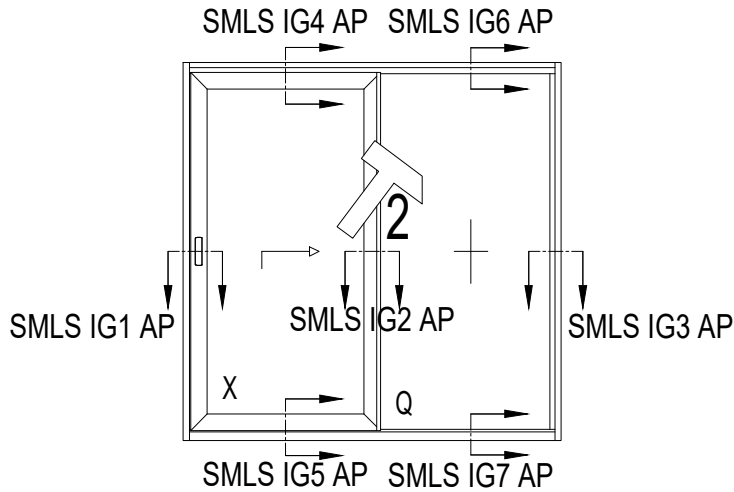

## SMLS IG4 AP

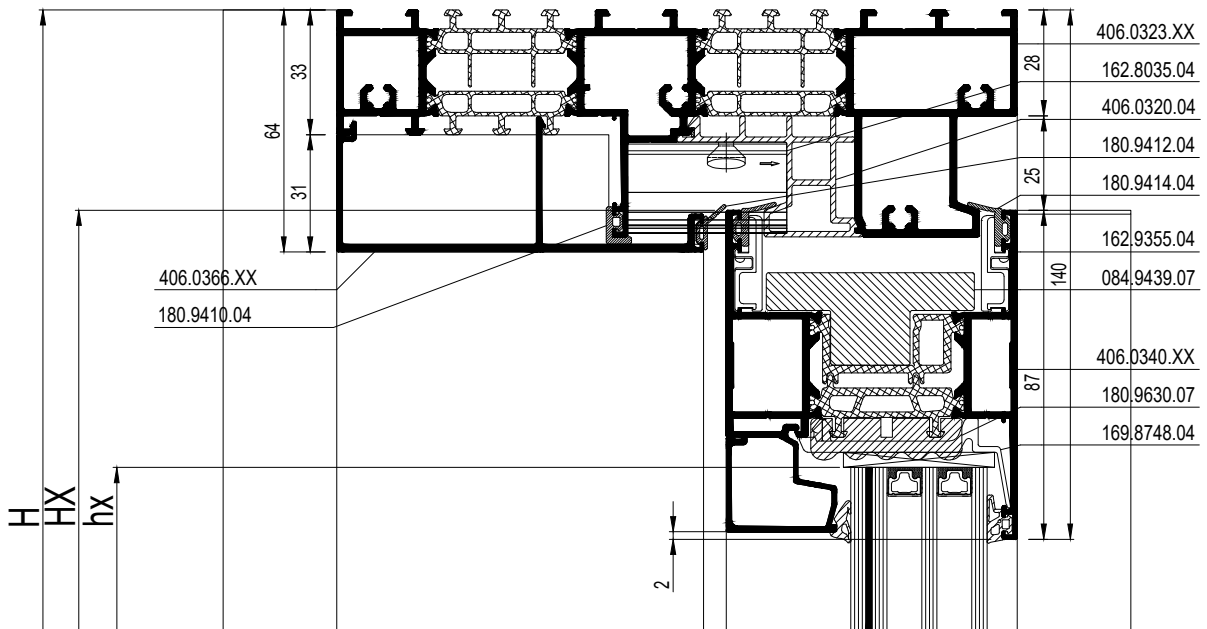

## SMLS IG5 AP

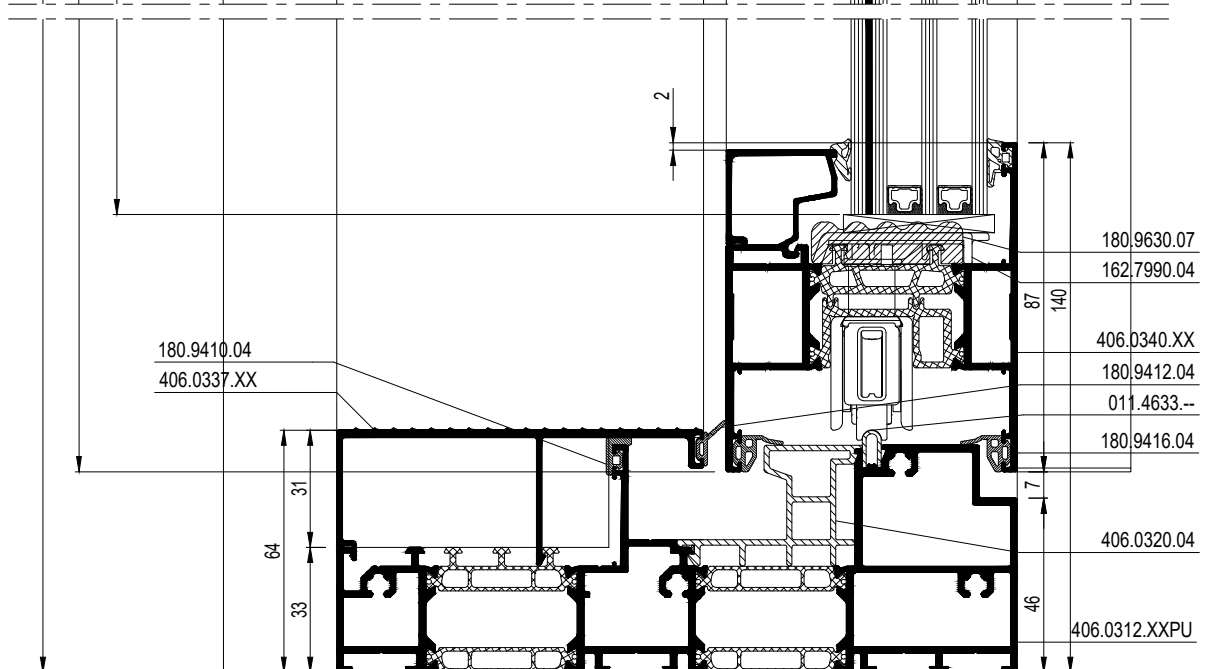

schaal - échelle  
 scale - Maßstab  
 1/2

## SMLS IG6 AP

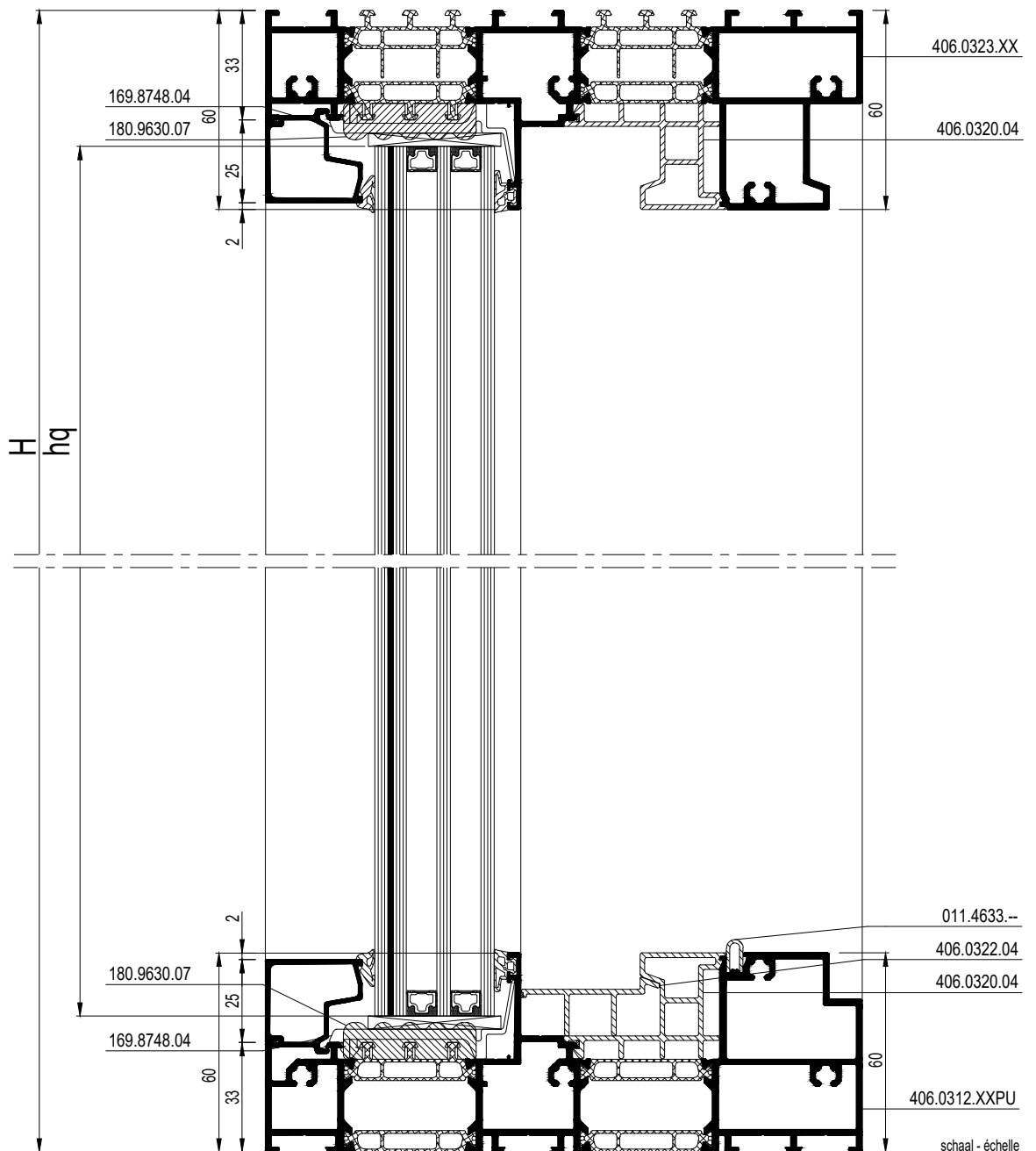



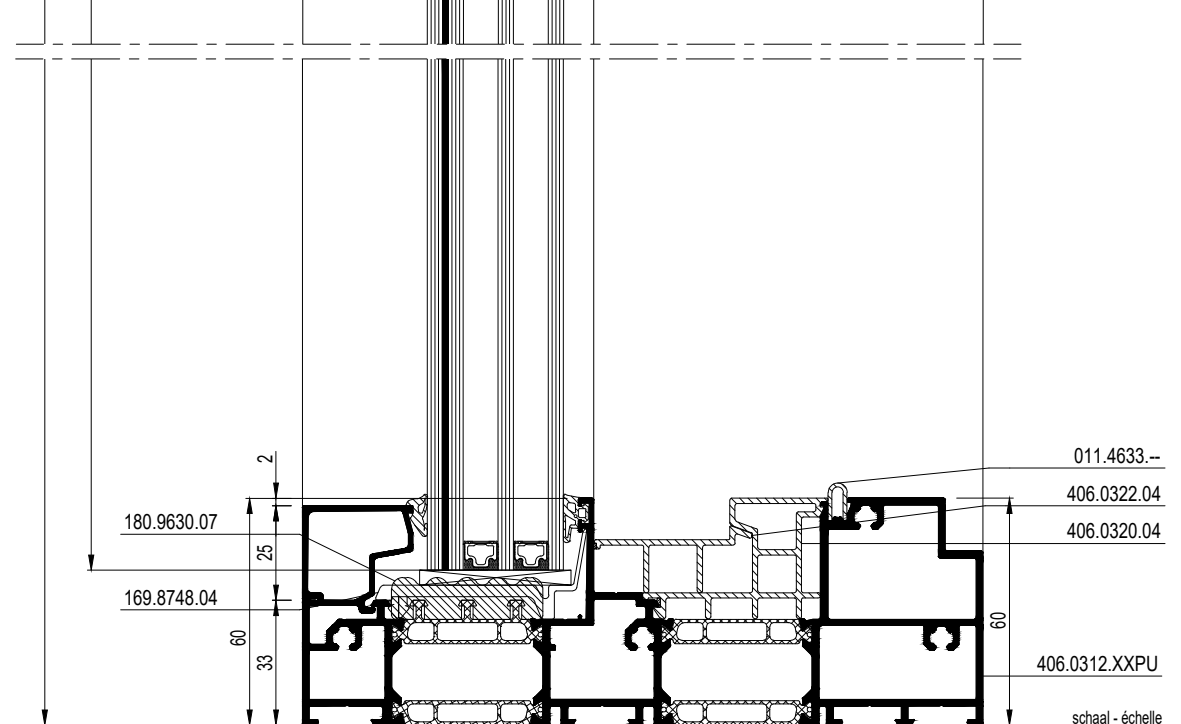



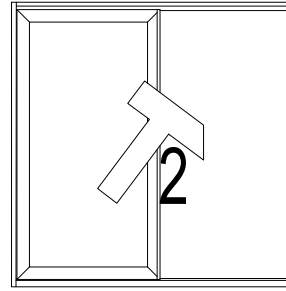
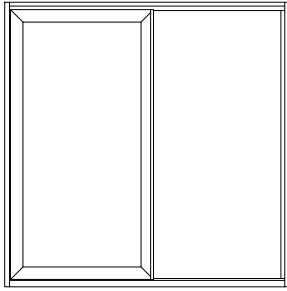

## SMLS IG7 AP

















schaal - échelle  
 scale - Maßstab  
 1/2













### MONORAIL XQ OUTSIDE/INSIDE GLAZED - STANDARD CHICANE

			#	← Lm →
030.3613.XX			2	H - 276
			2	B1 - 116.5
			2	H - 116
			2	B2 - 49.5

### AP MONORAIL XQ OUTSIDE/INSIDE GLAZED - STANDARD CHICANE







			#	← Lm →
130.3653.XX			2	H - 276
			2	B1 - 116.5
			2	H - 116
			2	B2 - 49.5
406.0090.00PU			1	H-108
			1	H
406.0091.XX			1	H-108
			1	H

		#
084.9439.07		B1 - 65
162.7930.--		min. 1
169.8748.04		12
162.7980.04		5

		#
084.9439.07		B1 - 200
162.7930.--		2
169.8748.04		14
050.5387.--		9
		2 / Lock point
050.5080.--		8
050.5081.--		8
162.7931.--		34G.F
169.6547.00		min. 6
052.5316.--		min. 18
062.8158.XX		1







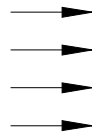





EXTRA

### MONORAIL OUTSIDE/INSIDE GLAZED - STANDARD CHICANE

		#
084.9439.07		B1 - 65
162.7930.--		min. 1 / Vent
169.8748.04		x
162.7980.04		5 / Vent









### AP MONORAIL OUTSIDE/INSIDE GLAZED - STANDARD CHICANE

		#
084.9439.07		B1 - 200
162.7930.--		2 / Vent
169.8748.04		x + 2 / Vent
050.5387.--		9 / X-Vent
		2 / Lock point
050.5080.--		8 / Vent
050.5081.--		8 / Vent
162.7931.--		34G.F
169.6547.00		min. 6 / Vent
052.5316.--		min. 18 / Vent
062.8158.XX		1 / 2-Vents







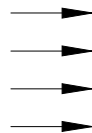





EXTRA

### MONORAIL OUTSIDE/INSIDE GLAZED - SLIM CHICANE

		#
084.9439.07		B1 - 65
162.7930.--		min. 1 / Vent
169.8748.04		x
162.7980.04		5 / Vent



### AP MONORAIL OUTSIDE/INSIDE GLAZED - SLIM CHICANE

		#
084.9439.07		B1 - 200
162.7930.--		2 / Vent
169.8748.04		x + 2 / Vent
050.5387.--		9 / X-Vent
		2 / Lock point
050.5080.--		8 / Vent
050.5081.--		8 / Vent
162.7931.--		34G.F
169.6547.00		min. 4 / Vent
052.5316.--		min. 12 / Vent
062.8158.XX		1 / 2-Vents

EXTRA

# MasterPatio Motorised

MONORAIL BINNENGLAZING VARIANT TOPPROFIEL  
MONORAIL INTERIEUR PARCLOUSE PROFILE EN HAUT VARIANTE  
MONORAIL INSIDE GLAZING VARIANT TOP PROFILE  
MONORAIL INNENGLASUNG VARIANTE OBEN PROFILE



E

GEMOTORISEERD  
MOTORISEE

MOTORISED  
MOTORISIERTES

MONORAIL INSIDE GLAZED - STANDARD TOP

				#	← Lm →
406.0323.XX			<input type="checkbox"/>	X	X
406.0320.XX			<input type="checkbox"/>	X	X
	(*) AFWERKINGSPROFIEL GEADVISEERD BIJ BINNENGLAZING (*) PROFIL DE FINITION CONSEILLÉ AVEC INTERIEUR PARCLOSE (*) FINISHING PROFILE ADVISED WITH INSIDE GLAZING (*) AUSFUEHRUNGSPROFIL EMPFOHLEN MIT INNENGLASUNG				

MONORAIL INSIDE GLAZED - VARIANT TOP

				#	← Lm →
406.0334.XX			<input type="checkbox"/>	X	X
406.0371.XX			<input type="checkbox"/>	X	34G.F
406.0372.04			<input type="checkbox"/>	X	X
EXTRA (*)406.0338.XX			<input type="checkbox"/>	X	X-1

EXTRA

			#
080.9381.04			34G.F
(*)162.8175.SY			1
(*)052.5300.--			(X-67)/300

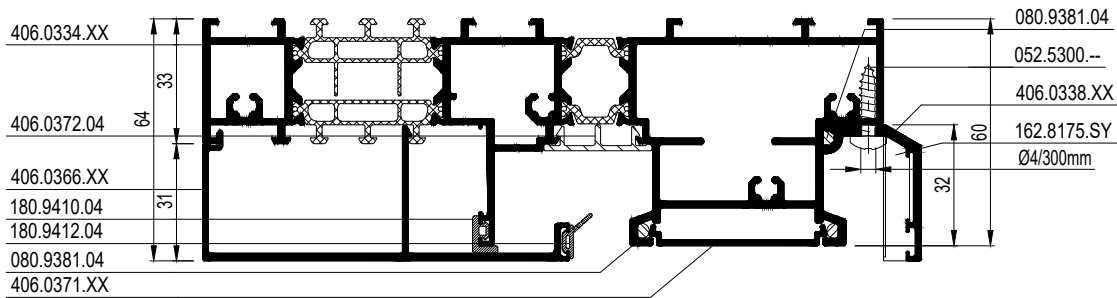
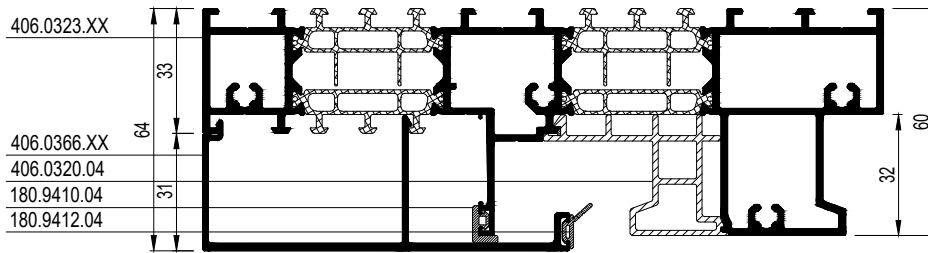

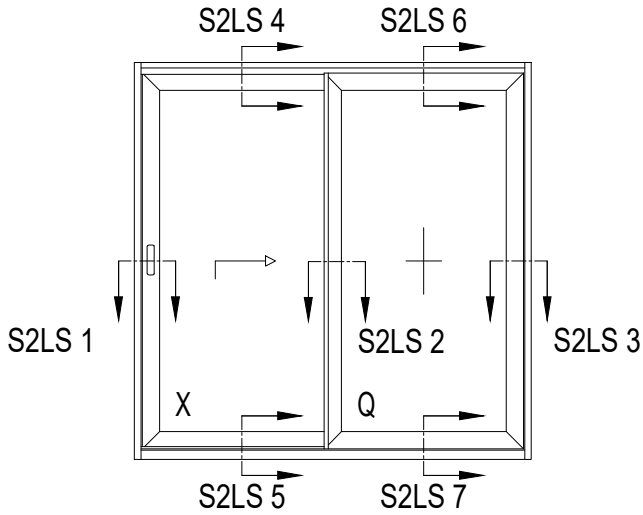

S2LS 1

S2LS 2

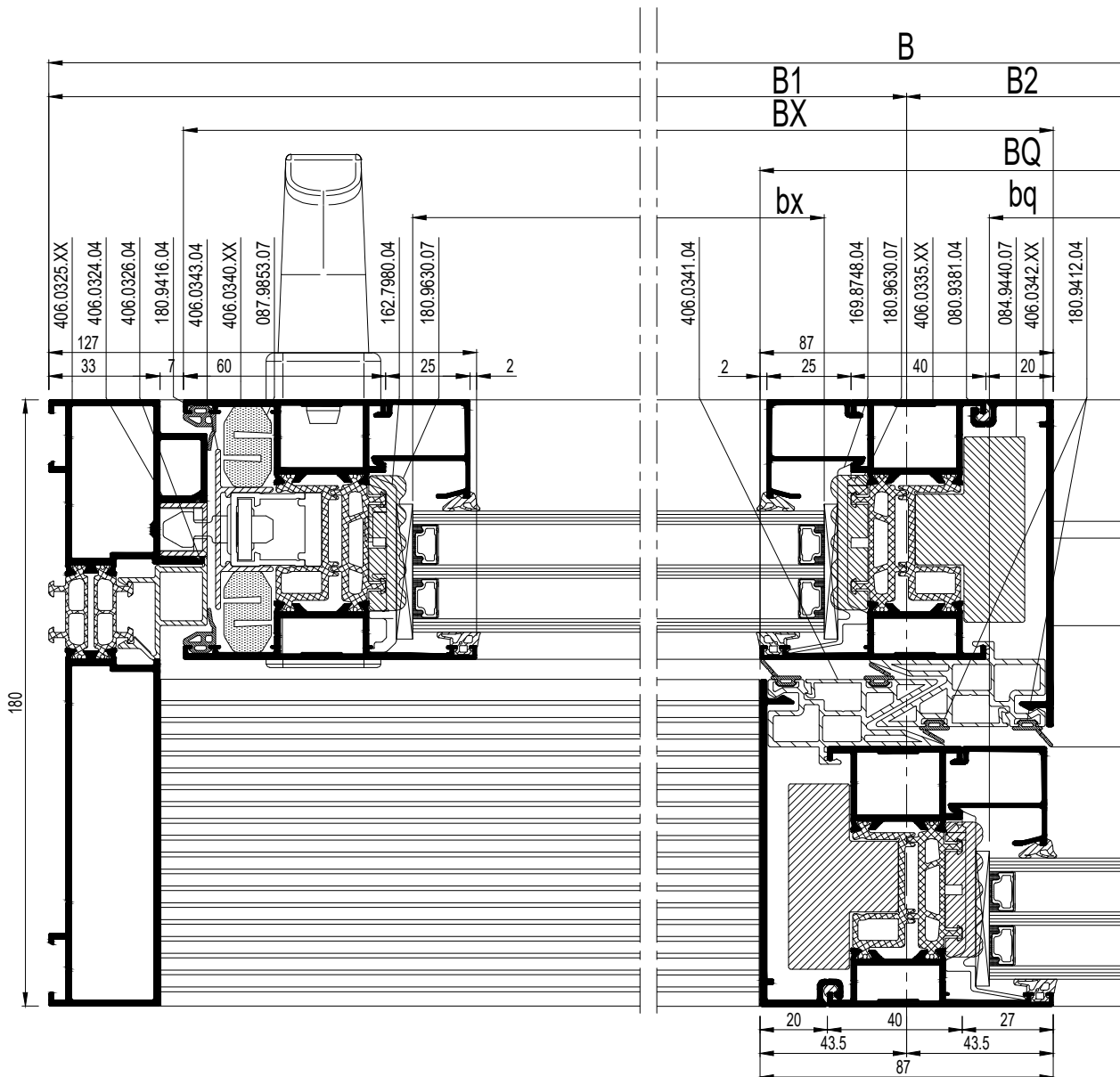

schaal - échelle  
 scale - Maßstab  
 1/2

## S2LS 3

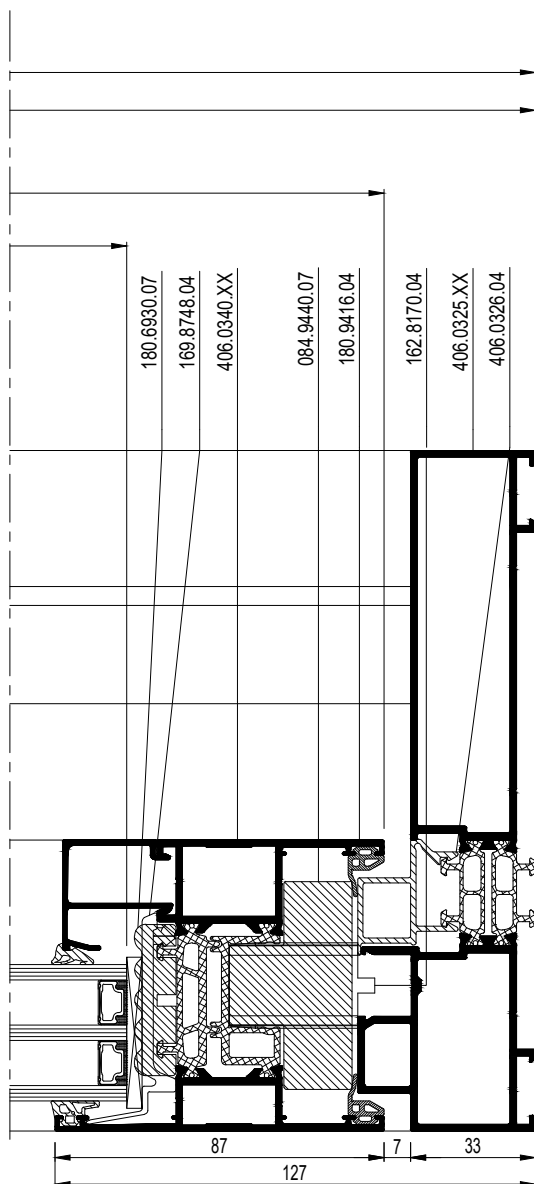

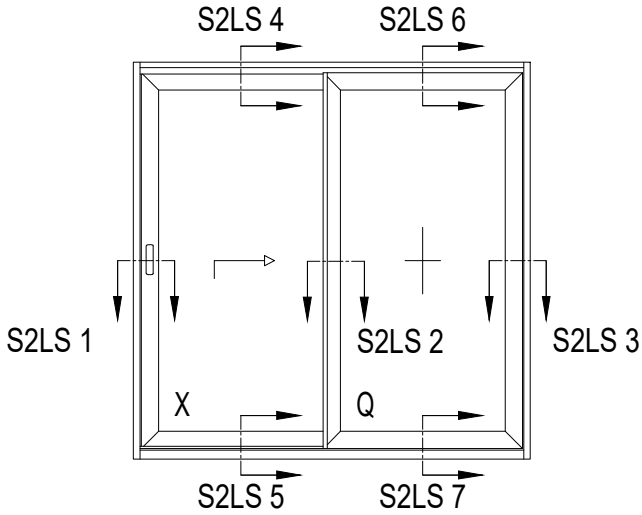

S2LS 4

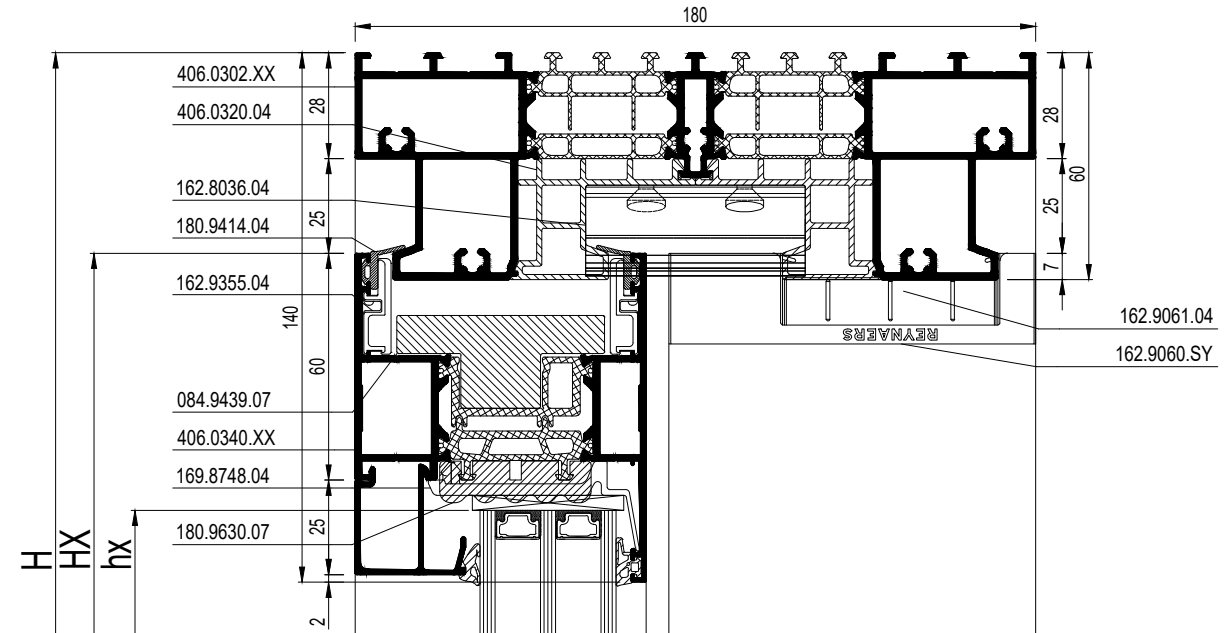

S2LS 5

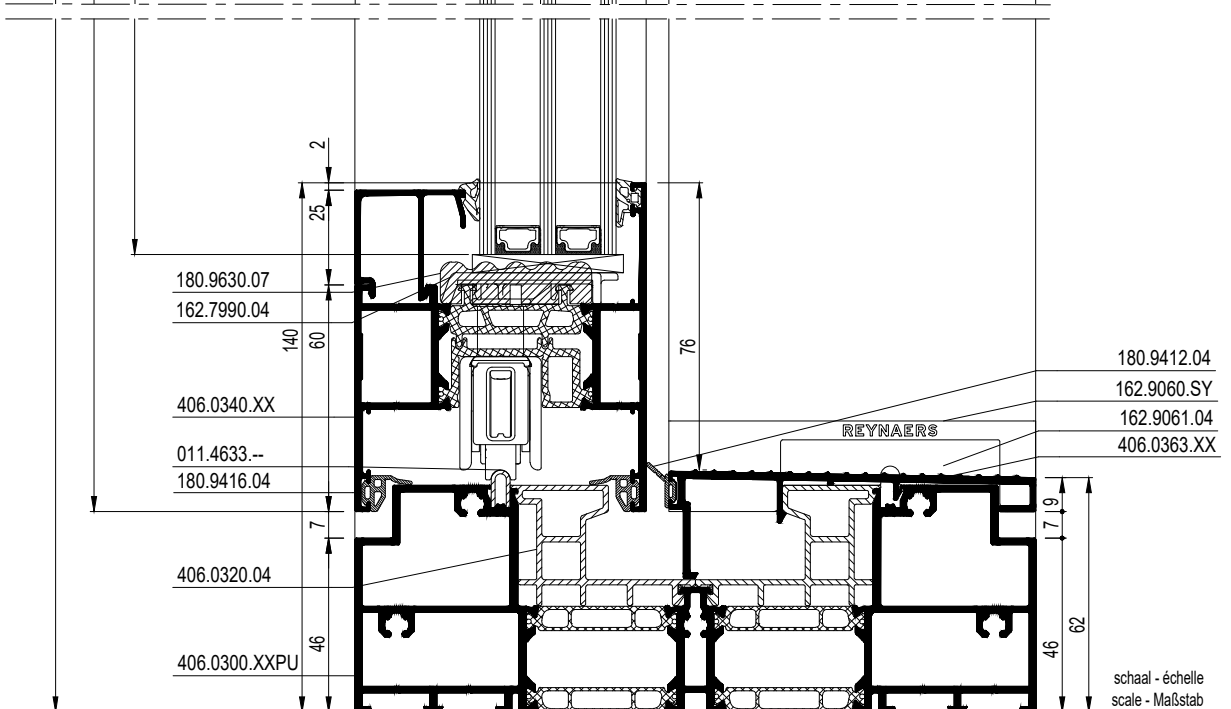

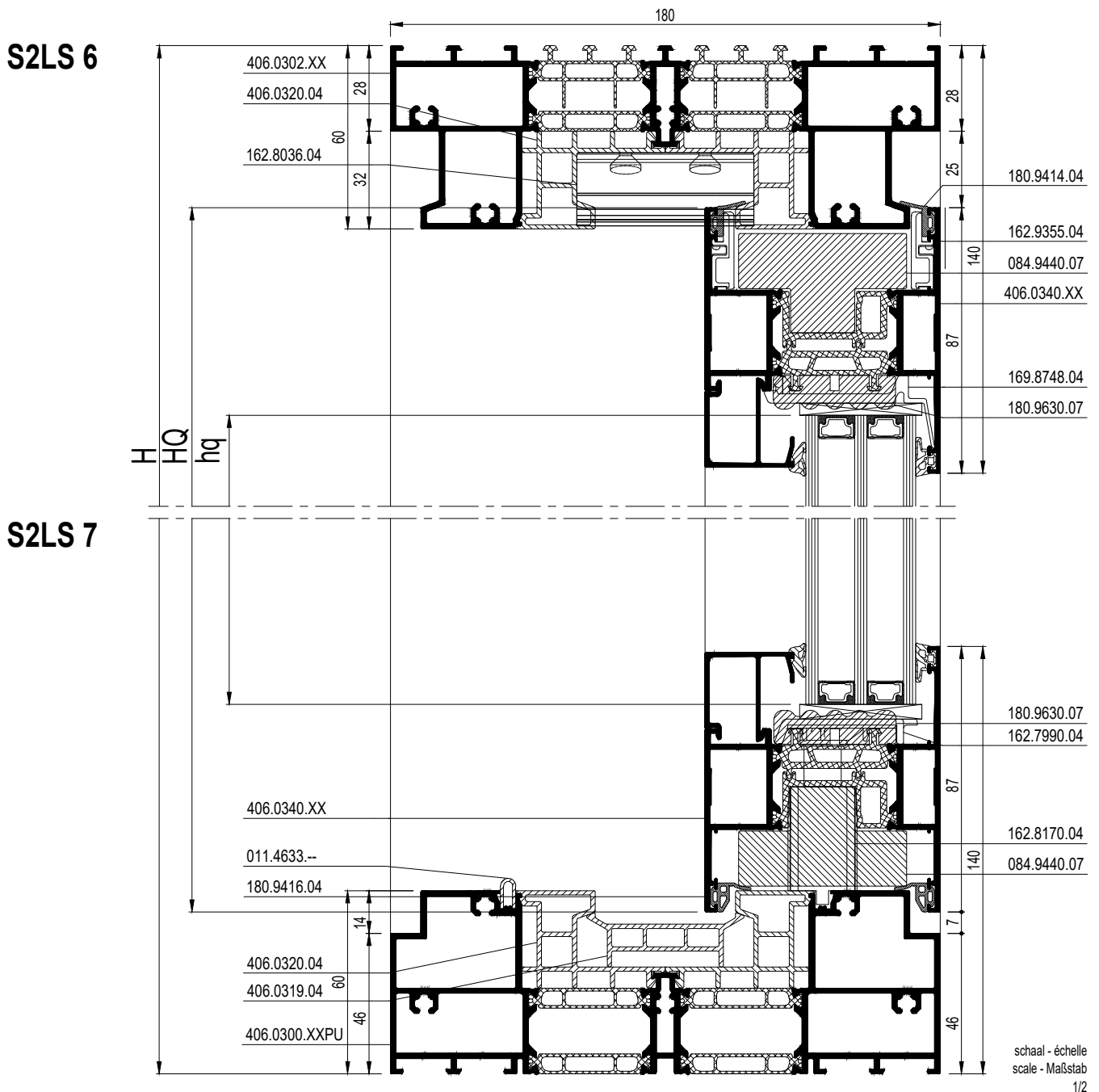

			#	$\leftarrow L_m \rightarrow$
406.0300.XXPU			1	B - 66
406.0302.XX			1	B - 66
406.0325.XX			2	H
406.0319.04			1	B2 - 73.5
406.0320.04			4	B - 66
011.4633.--			1	B - 80
406.0326.04			2	H - 120
406.0324.04			1	H - 120 *
406.0363.XX			1	B1 - 77
406.0340.XX			2	H - 106
			2	B1 + 3.5 (-20)
			2	B2 + 3.5 (-20)
406.0343.04			1	H - 176
030.3613.XX			4	H - 276
			2	B1 - 116.5
			2	B2 - 116.5
406.0335.XX			2	H - 146
406.0341.04			2	H - 106
406.0342.XX			2	H - 154
0M0.1505.00			1	34G.F

	BX = B1+3.5
	BQ = B2+3.5
	HX = H-106
	HQ = H-106
	bx = BX-136
	bq = BQ-136
	hx = HX-136
	hq = HQ-136

		#
052.5371.--		20
168.8105.00		8
168.5012.--		8
168.8106.00		8
050.5091.--		16
160.8725.--		8
160.8750.--		8
052.5300.--		2 x (H / 300)
162.7980.04		5
162.7990.04		5
169.8748.04		10
162.8170.04		7
050.5081.--		4
052.5305.--		5
162.9355.04		12
162.8172.04		1
080.9124.SY		2B + 4H
080.9381.04		2H
180.9114.SY		2B + 4H
080.9724.04		4
084.9440.07		B2 - 119.5
		B2 - 254.5 *
		H - 159
		H - 185
		H - 255 *
084.9439.07		B1 - 65
087.9853.07		2 x (H - 160)
180.9630.07		2B + 4H
Lock set		1
Wheels set		1
162.7930.--		min. 1
162.8036.04		1
052.5309.--		2
162.9060.SY		2
162.9061.04		2
162.8081.04		4
162.8063.04		2
162.9312.04		2
180.9160.04		B
180.9412.04		B1 + 4H
180.9414.04		2B
180.9416.04		2B + 4H
180.9493.04		2
062.7715.XX		34G.F
069.6830.04		34G.F

\* KNIP IN STUKKEN  
\* COUPE EN MORCEAUX  
\* CUT IN PIECES  
\* IN STUCKE SCHNEIDEN



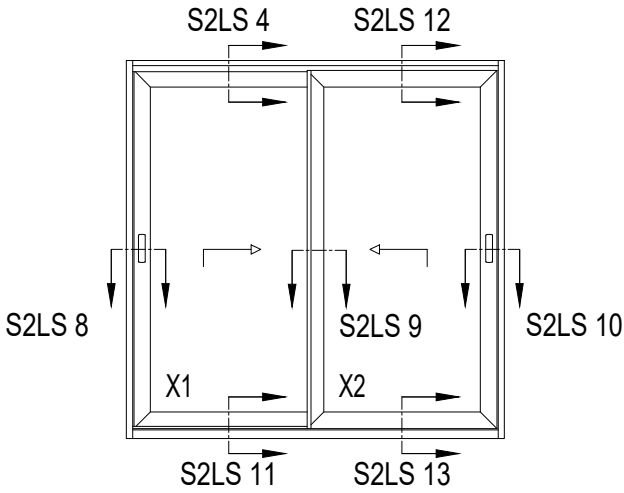

S2LS 8

S2LS 9

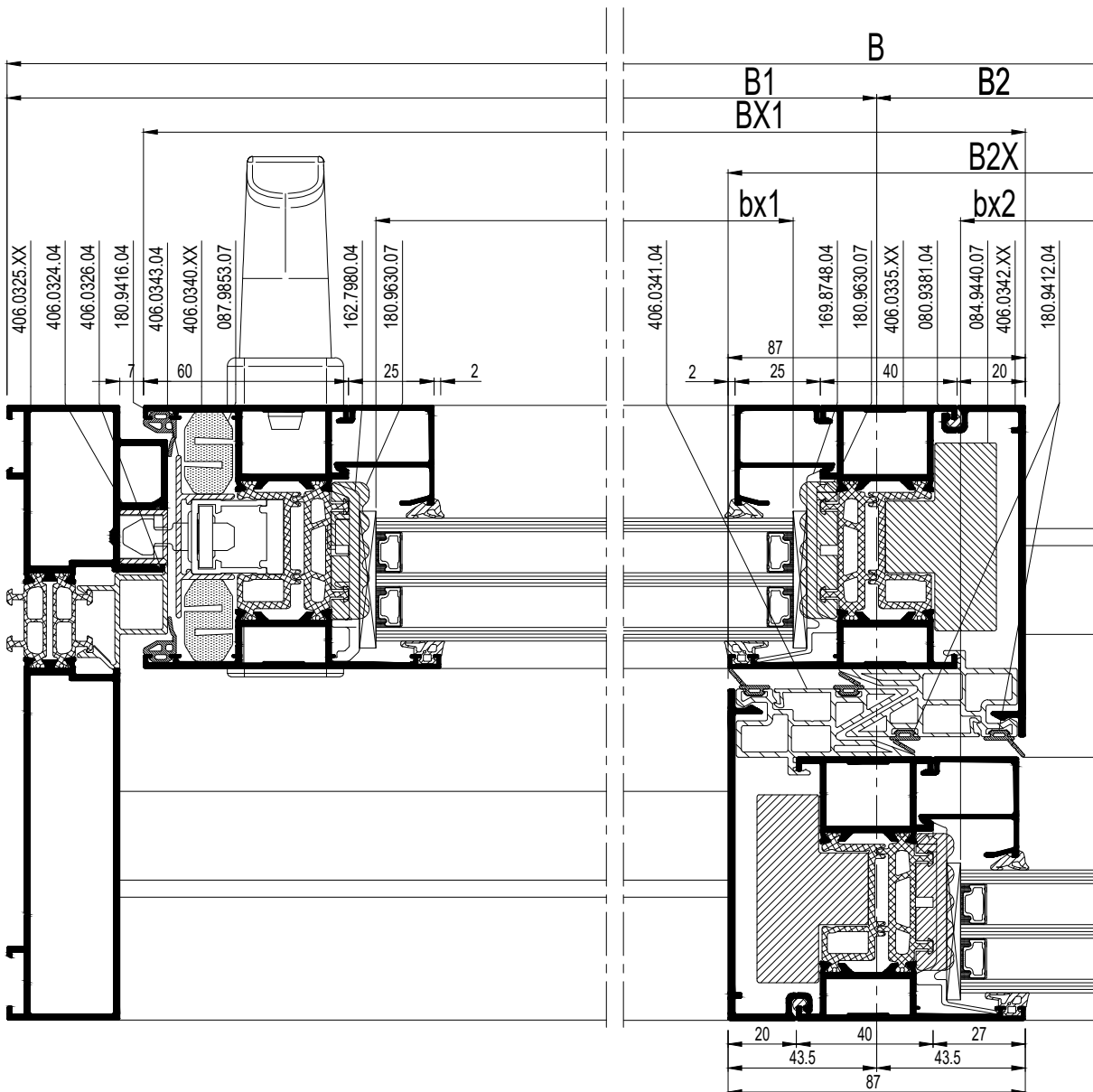

schaal - échelle  
 scale - Maßstab  
 1/2

## S2LS 10

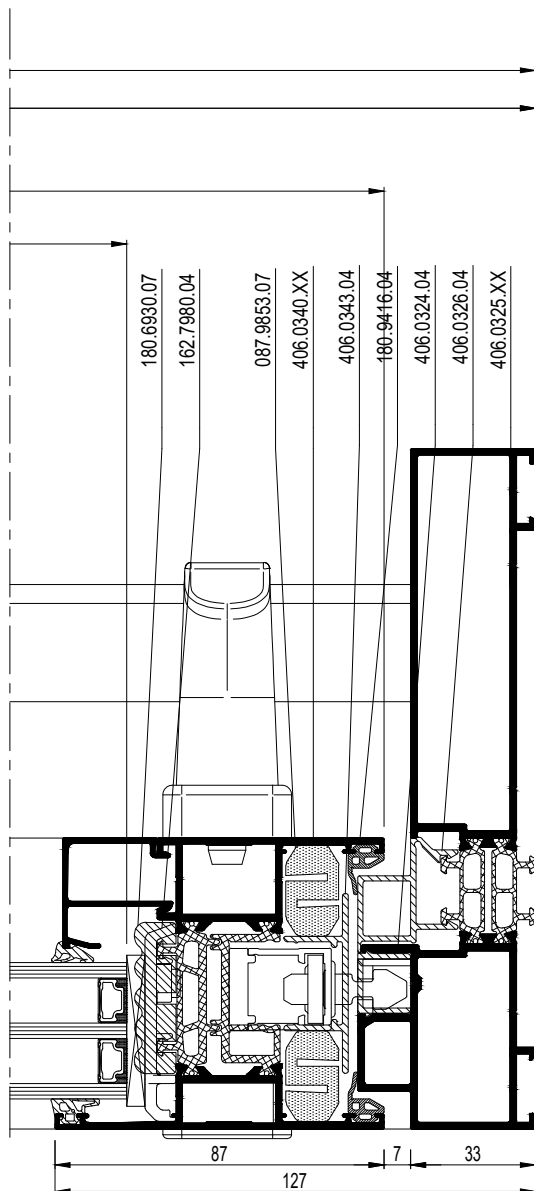

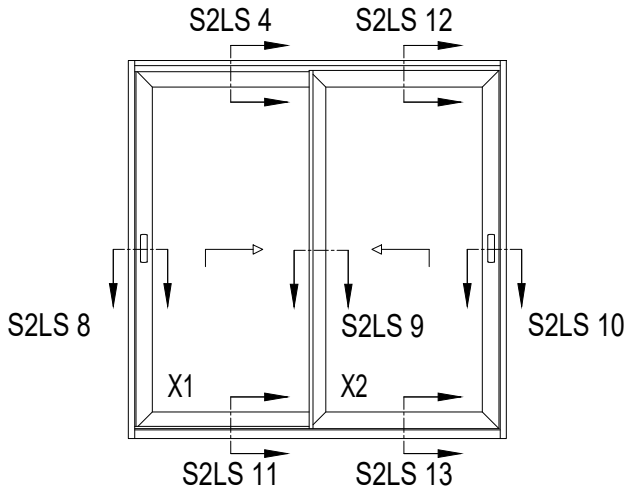

S2LS 11

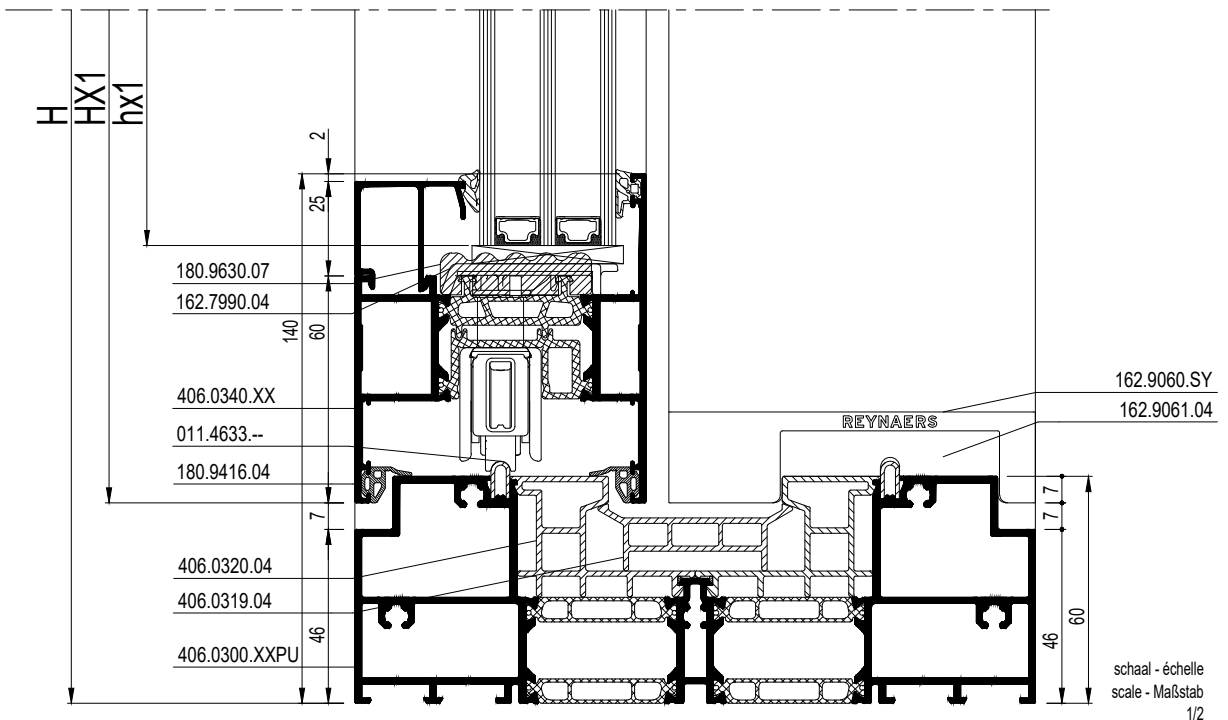

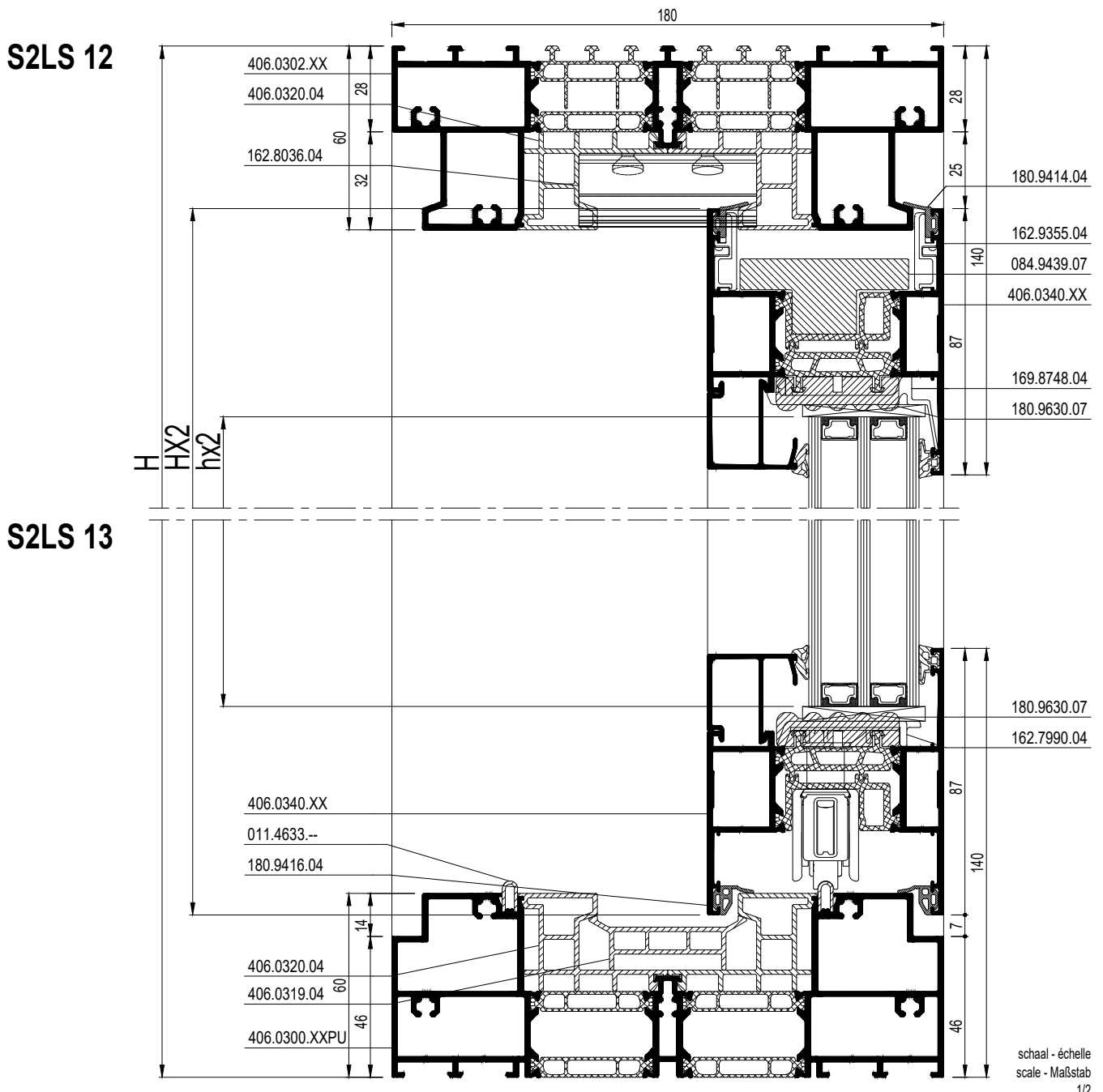

			#	$L_m$
406.0300.XXPU			1	B - 66
406.0302.XX			1	B - 66
406.0325.XX			2	H
406.0319.04			1	B1 - 73.5
			1	B2 - 73.5
406.0320.04			4	B - 66
011.4633.--			2	B - 80
406.0326.04			2	H - 120
406.0324.04			2	H - 120 *
406.0340.XX			2	H - 106
			2	B1 + 3.5 (-20)
			2	B2 + 3.5 (-20)
406.0343.04			2	H - 176
030.3613.XX			4	H - 276
			2	B1 - 116.5
			2	B2 - 116.5
406.0335.XX			2	H - 146
406.0341.04			2	H - 106
406.0342.XX			2	H - 154
0M0.1505.00			2	34G.F

BX1 = B1+3.5
BX2 = B2+3.5
HX = H-106
bx1 = BX1-136
bx2 = BX2-136
hx = HX-136

		#
052.5371.--		20
168.8105.00		8
168.5012.--		8
168.8106.00		8
050.5091.--		16
160.8725.--		8
160.8750.--		8
052.5300.--		2 x (H / 300)
162.7980.04		10
162.7990.04		5
169.8748.04		8
162.9355.04		12
080.9124.SY		2B + 4H
080.9381.04		2H
180.9114.SY		2B + 4H
080.9724.04		4
084.9440.07		2 x (H - 159)
084.9439.07		B1 - 65
		B2 - 65
087.9853.07		4 x (H - 160)
180.9630.07		2B + 4H
Lock set		2
Wheels set		2
162.7930.--		min. 2
162.8036.04		1
052.5309.--		2
162.9060.SY		2
162.9061.04		2
162.8081.04		4
162.8063.04		2
162.9312.04		2
180.9160.04		2B
180.9412.04		4H
180.9414.04		2B
180.9416.04		2B + 4H
180.9493.04		2
062.7715.XX		34G.F
069.6830.04		34G.F

\* KNIP IN STUKKEN  
\* COUPE EN MORCEAUX  
\* CUT IN PIECES  
\* IN STÜCKE SCHNEIDEN



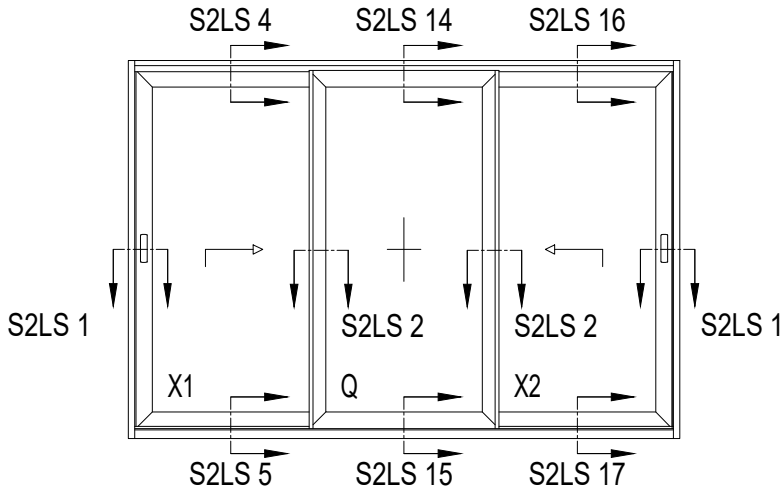

S2LS 14

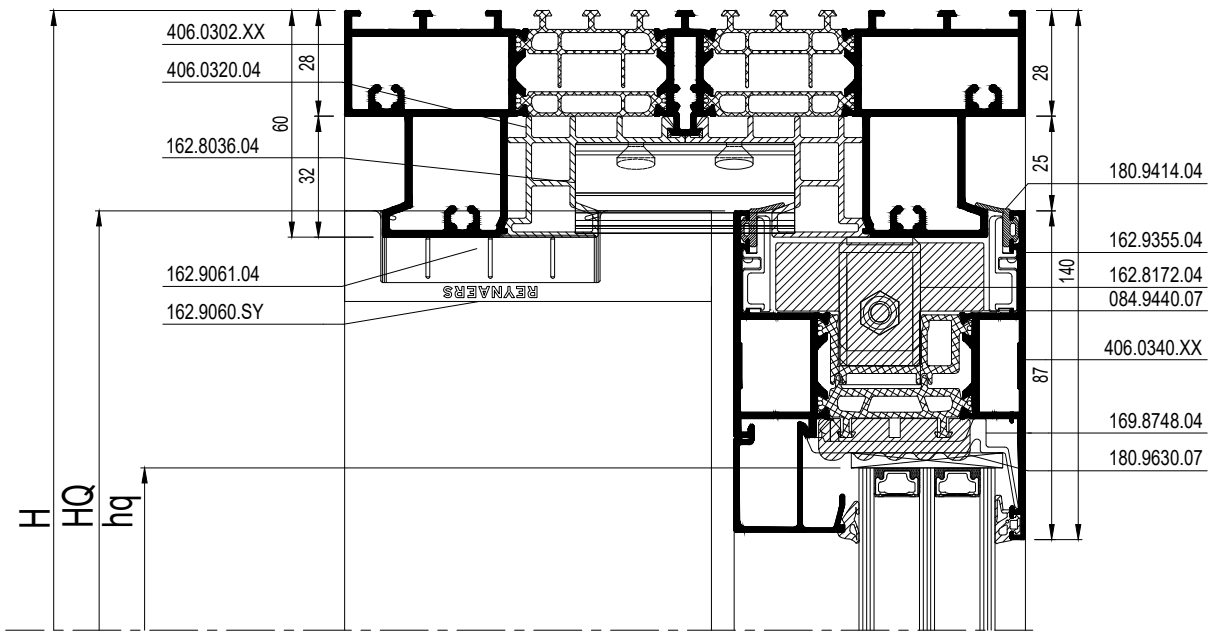

S2LS 15

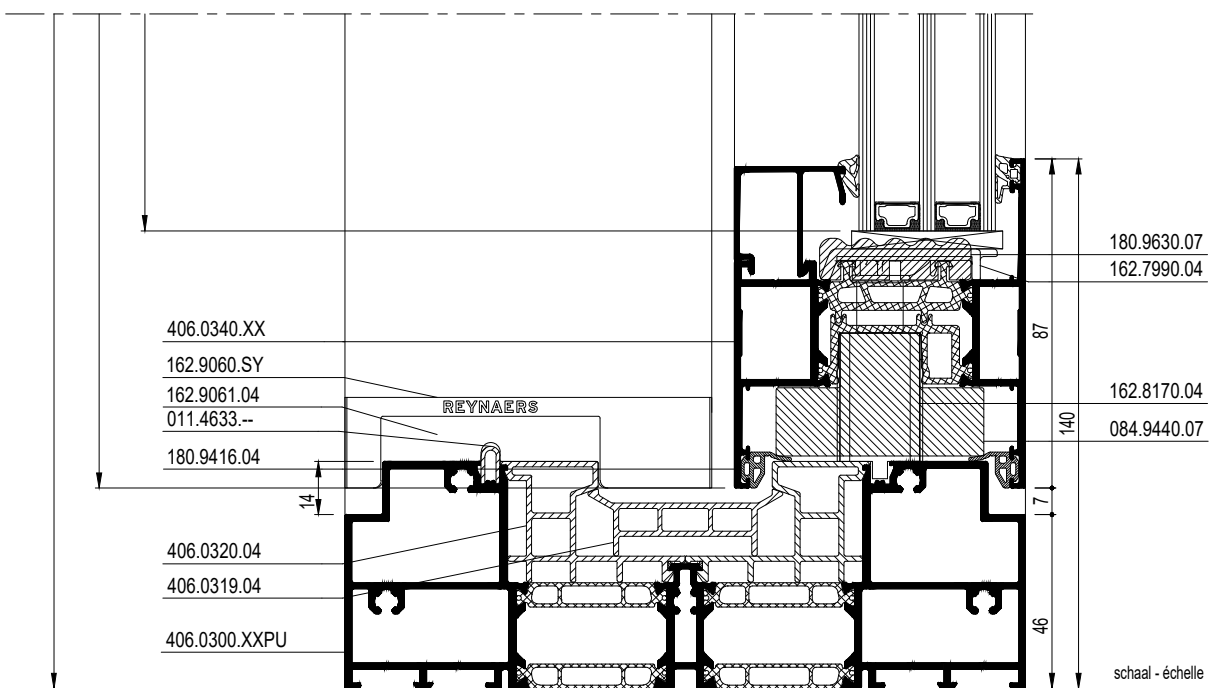

schaal - échelle  
 scale - Maßstab  
 1/2

S2LS 16

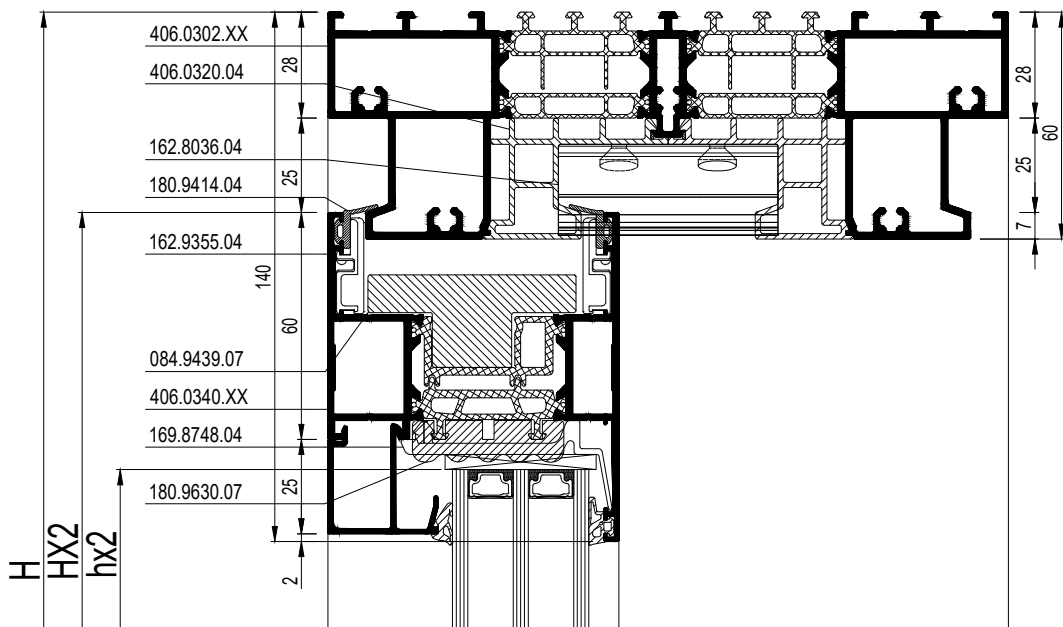

S2LS 17

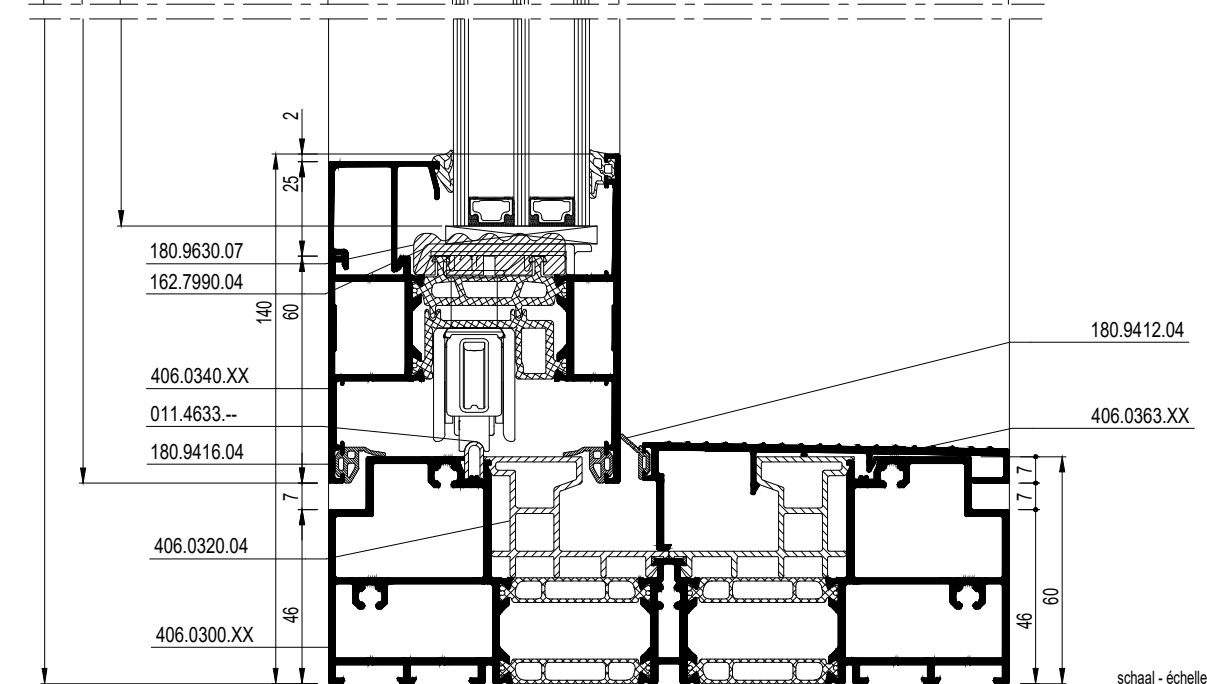

schaal - échelle  
 scale - Maßstab  
 1/2

			#	$\leftarrow L_m \rightarrow$
406.0300.XXPU			1	B - 66
406.0302.XX			1	B - 66
406.0325.XX			2	H
406.0319.04			1	B2 - 81
406.0320.04			4	B - 66
011.4633.--			1	B - 80
406.0326.04			2	H - 120
406.0324.04			2	H - 120 *
406.0363.XX			1	B1 - 77
			1	B3 - 77
406.0340.XX			2	H - 106
			2	B1 + 3.5 (-20)
			2	B2 + 87 (-40)
			2	B3 + 3.5 (-20)
406.0343.04			2	H - 176
030.3613.XX			6	H - 276
			2	B1 - 116.5
			2	B2 - 33
			2	B3 - 116.5
406.0335.XX			4	H - 146
406.0341.04			4	H - 106
406.0342.XX			4	H - 154
0M0.1505.00			2	34G.F

\* KNIP IN STUKKEN  
\* COUPE EN MORCEAUX  
\* CUT IN PIECES  
\* IN STUCKE SCHNEIDEN

	BX1 = B1+3.5
	BQ = B2-87
	BX2 = B3+3.5
	HX = H-106
	HQ = H-106
	bx1 = BX1-136
	bx2 = BX2-136
	bq = BQ-136
	hx = HX-136
	hq = HQ-136

		#
052.5371.--		20
168.8105.00		12
168.5012.--		12
168.8106.00		12
050.5091.--		24
160.8725.--		8
160.8750.--		12
052.5300.--		4 x (H / 300)
162.7980.04		10
162.7990.04		7
169.8748.04		14
162.8170.04		4
050.5081.--		4
052.5305.--		2
162.9355.04		18
162.8172.04		2
080.9124.SY		2B + 6H
080.9381.04		4H
180.9114.SY		2B + 6H
080.9724.04		4
084.9440.07		B2 - 77
		B2 - 171 *
		4 x (H - 159)
084.9439.07		B1 - 65
		B3 - 65
087.9853.07		4 x (H - 160)
180.9630.07		2B + 6H
Lock set		2
Wheels set		2
162.7930.--		min. 2
162.8036.04		2
052.5309.--		4
162.9060.SY		4
162.9061.04		4
162.8081.04		4
162.8062.04		2
162.8063.04		2
162.9312.04		2
180.9160.04		B
180.9412.04		B1 + B3 + 8H
180.9414.04		2B
180.9416.04		2B + 4H
180.9493.04		2
062.7715.XX		34G.F
069.6830.04		34G.F



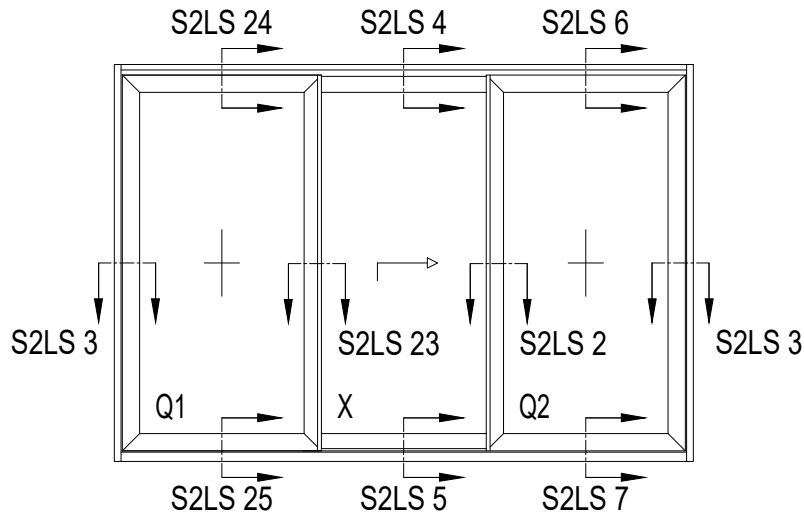

S2LS 23

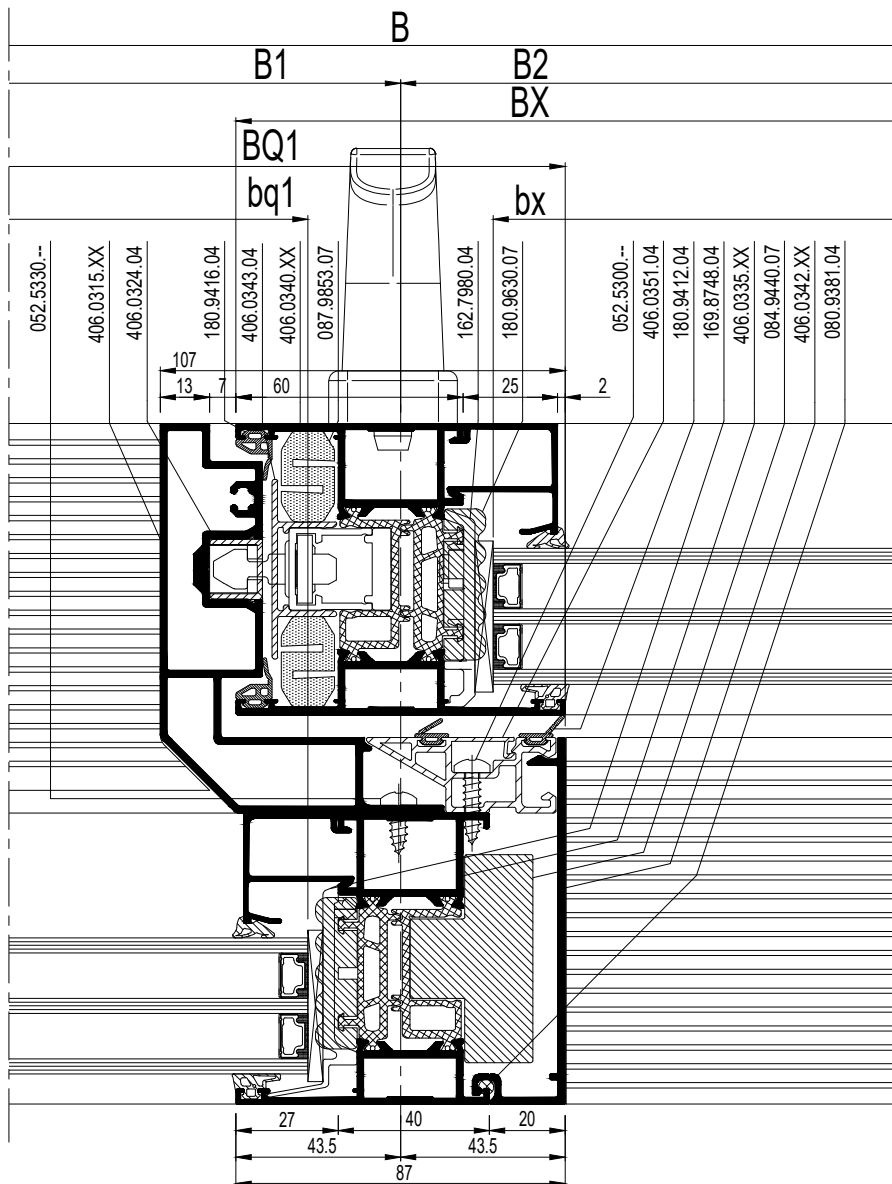

schaal - échelle  
 scale - Maßstab  
 1/2

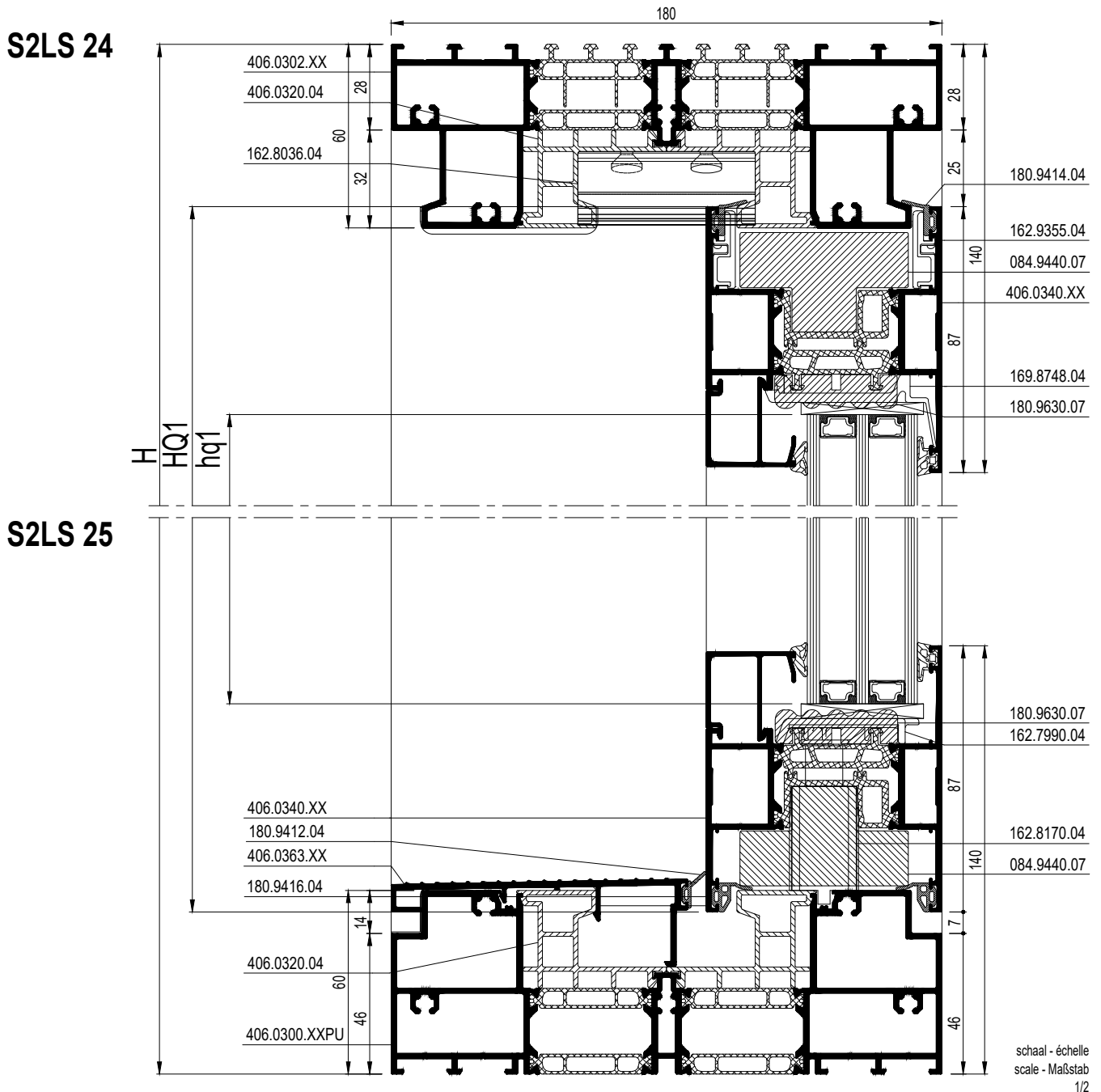









			#	Lm
406.0300.XXPU			1	B - 66
406.0302.XX			1	B - 66
406.0325.XX			2	H
406.0319.04			1	B3 - 73.5
406.0320.04			4	B - 66
011.4633.--			1	B2 + B3 + 3.5
406.0326.04			2	H - 120
406.0324.04			1	H - 120 *
406.0363.XX			1	B2 - 87.5
406.0340.XX			3	H - 106
			2	B1 + 3.5 (-20)
			2	B2 + 87 (-20)
			2	B3 + 3.5 (-20)
406.0343.04		1	H - 176	
030.3613.XX			6	H - 276
			2	B1 - 116.5
			2	B2 - 33
			2	B3 - 116.5
406.0335.XX		3	H - 146	
406.0341.04		2	H - 106	
406.0342.XX		3	H - 154	
0M0.1505.00			1	34G.F
406.0351.04			1	H - 106
406.0315.XX			1	H - 65.5
406.0363.XX			1	B1 - 83.5

	BQ1 = B1+3.5
	BX = B2+87
	BQ2 = B3+3.5
	HX = H-106
	HQ = H-106
	bq1 = BQ1-136
	bx = BX-136
	bq2 = BQ2-136
	hx = HX-136
	hq = HQ-136

		#
052.5371.--		20
168.8105.00		12
168.5012.--		12
168.8106.00		12
050.5091.--		24
160.8725.--		12
160.8750.--		12
052.5300.--		3 x (H / 300)
162.7980.04		5
162.7990.04		7
169.8748.04		16
162.8170.04		14
050.5081.--		8
052.5305.--		10
162.9355.04		18
162.8172.04		2
080.9124.SY		2B + 6H
080.9381.04		3H
180.9114.SY		2B + 6H
080.9724.04		4
084.9440.07		B1 - 119.5
		B1 - 254.5 *
		B3 - 119.5
		B3 - 254.5 *
		H - 159
		2x (H - 185)
		2x (H - 255) *
084.9439.07		B2 + 18.5
087.9853.07		2 x (H - 160)
180.9630.07		2B + 6H
Lock set		1
Wheels set		1
162.7930.--		min. 1
162.8036.04		2
052.5309.--		4
162.9060.SY		3
162.9061.04		3
162.8081.04		4
162.8062.04		2
162.8063.04		2
162.9312.04		2
180.9160.04		(B2+B3)
180.9412.04		B2 + 6H
180.9414.04		2B
180.9416.04		2B + 6H
180.9493.04		3
062.7715.XX		34G.F

\* KNIP IN STUKKEN  
\* COUPE EN MORCEAUX  
\* CUT IN PIECES  
\* IN STUCKE SCHNEIDEN

		#
069.6830.04		 34G.F
162.8100.--		2
052.5360.--		2
052.5310.--		2
052.5330.--		H / 300

E

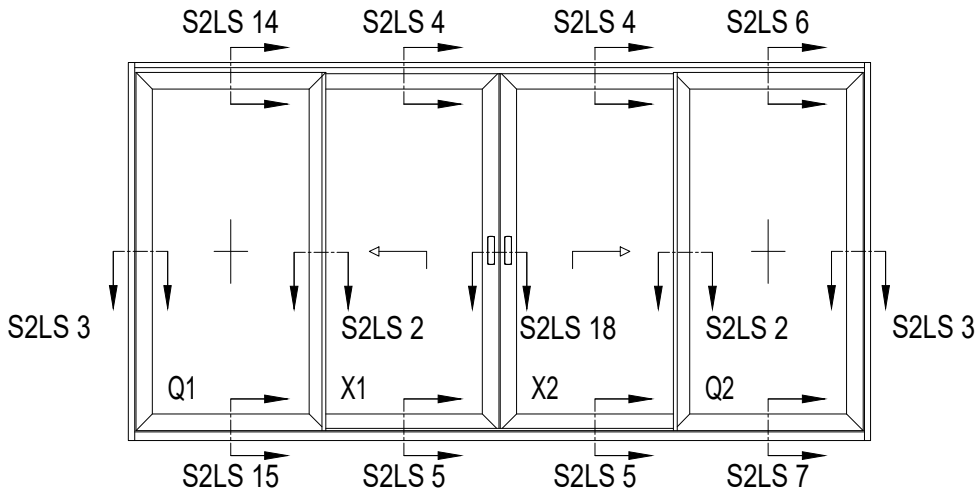

S2LS 18

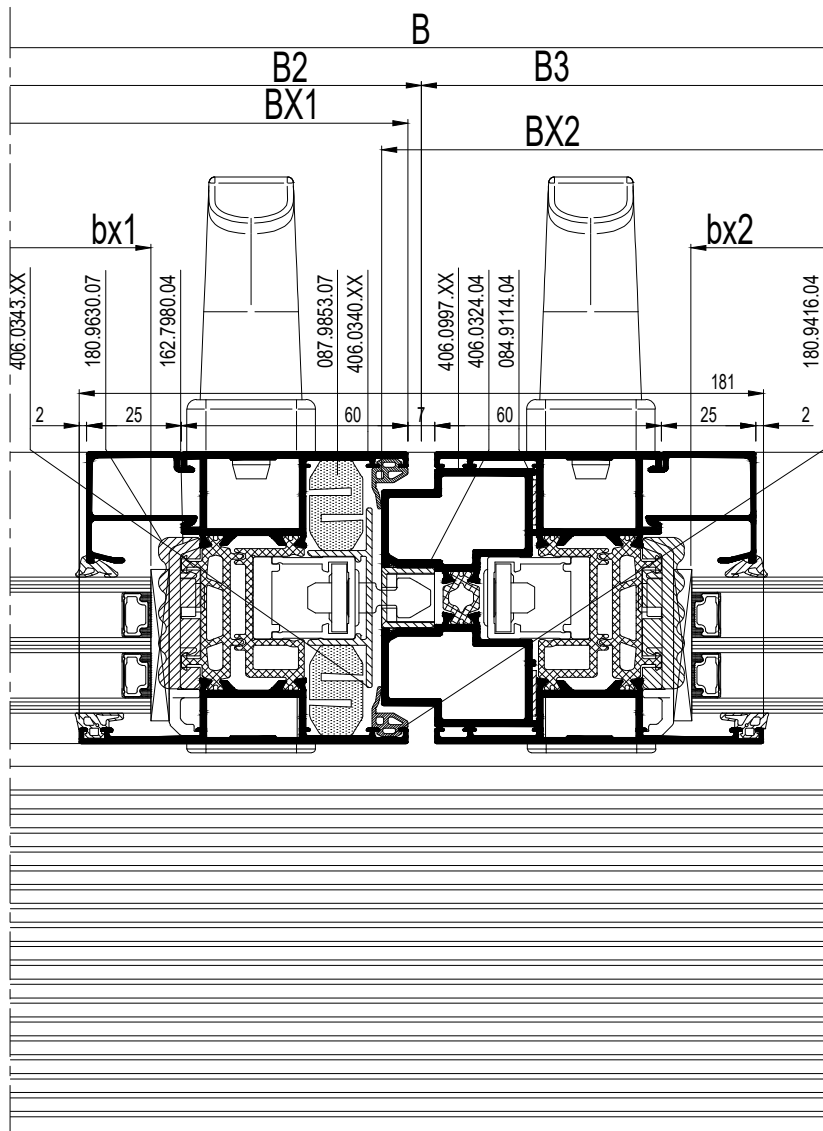

			#	$L_m$
406.0300.XXPU			1	B - 66
406.0302.XX			1	B - 66
406.0325.XX			2	H
406.0319.04			1	B1 - 73.5
			1	B4 - 73.5
406.0320.04			4	B - 66
011.4633.--			1	(B1+B2) - 9.5
			1	(B3+B4) - 89.5
406.0326.04			2	H - 120
406.0324.04			1	H - 188 *
406.0363.XX			1	(B2+B3) - 87.5
406.0340.XX			4	H - 106
			2	B1 + 3.5 (-20)
			2	B2 + 40 (-20)
			2	B3 + 40 (-20)
			2	B4 + 3.5 (-20)
406.0343.04			1	H - 176
030.3613.XX			8	H - 276
			2	B1 - 116.5
			2	B2 - 80
			2	B3 - 80
			2	B4 - 116.5
406.0335.XX			4	H - 146
406.0341.04			4	H - 106
406.0342.XX			4	H - 154
406.0997.XX			1	H - 192
0M0.1505.00			2	34G.F

	BQ1 = B1+3.5
	BX1 = B2+40
	BX2 = B3+54
	BQ2 = B4+3.5
	HQ = H-106
	HX = H-106
	bq1 = BQ1-136
	bx1=BX1-136
	bx2=BX2-150
	bq2 = BQ2-136
	hq = HQ-136
	hx = HX-136

		#
052.5371.--		20
168.8105.00		16
168.5012.--		16
168.8106.00		16
050.5091.--		32
160.8725.--		16
160.8750.--		16
052.5300.--		4 x (H / 300)
050.5074.--		34G.F
162.7980.04		10
162.7990.04		9
169.8748.04		20
162.8170.04		14
050.5081.--		8
052.5305.--		10
162.9355.04		24
162.8172.04		2
080.9124.SY		2B + 8H
080.9381.04		4H
180.9114.SY		2B + 8H
084.9114.04		2H
080.9724.04		4
084.9440.07		B1 - 119.5
		B1 - 254.5 *
		B4 - 119.5
		B4 - 254.5 *
		2 x (H - 159)
		2 x (H - 185)
		2 x (H - 255) *
084.9439.07		B2 - 28.5
		B3 - 28.5
087.9853.07		2 x (H - 160)
180.9630.07		2B + 8H
Lock set		1
Lcok set		1 **
Wheels set		2
162.7930.--		min. 1
162.7940.--		1
162.8036.04		2
052.5309.--		4
162.9060.SY		4
162.9061.04		4
180.8120.04		1
180.9412.04		B2 + B3 + 8H
180.9414.04		2B
180.9416.04		2B + 6H
180.9493.04		3
069.6830.04		34G.F
162.8081.04		4
162.8062.04		2
162.8063.04		2
162.9312.04		2
180.9160.04		B
062.7715.XX		34G.F

\* KNIP IN STUKKEN  
\* COUPE EN MORCEAUX  
\* CUT IN PIECES  
\* IN STUCKE SCHNEIDEN



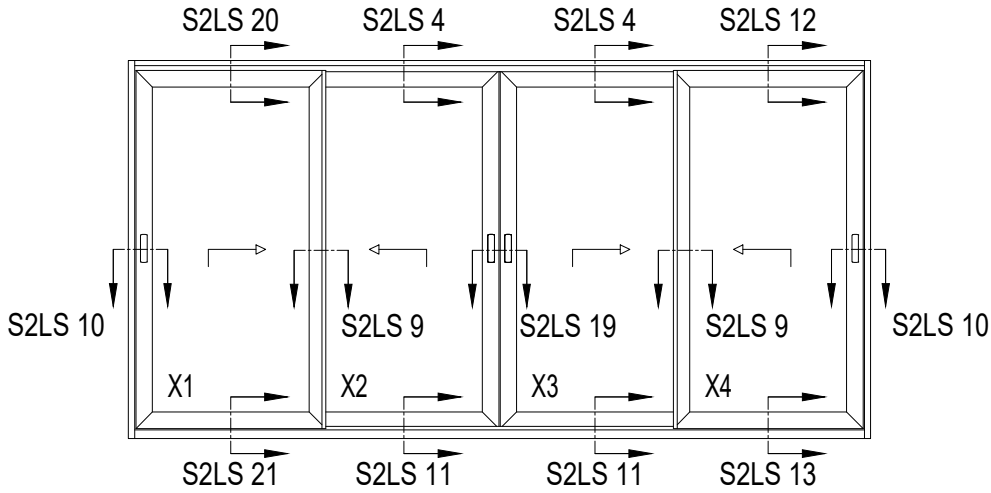



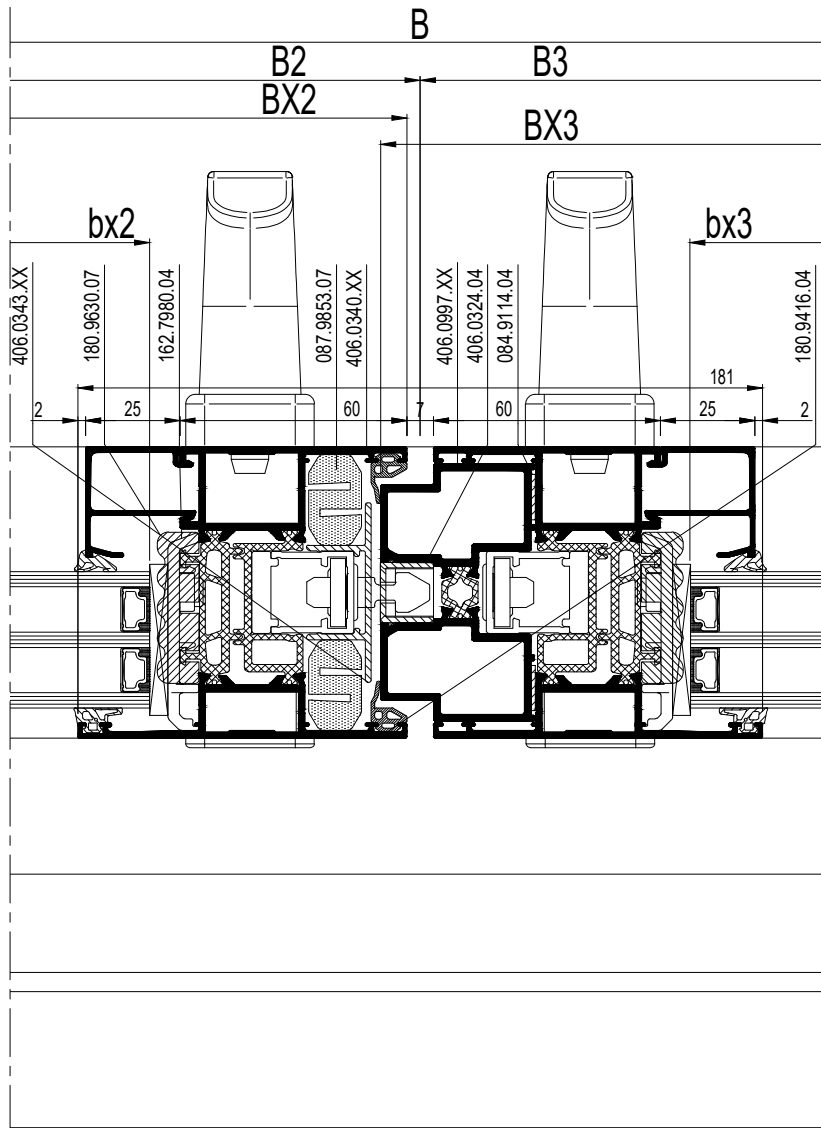

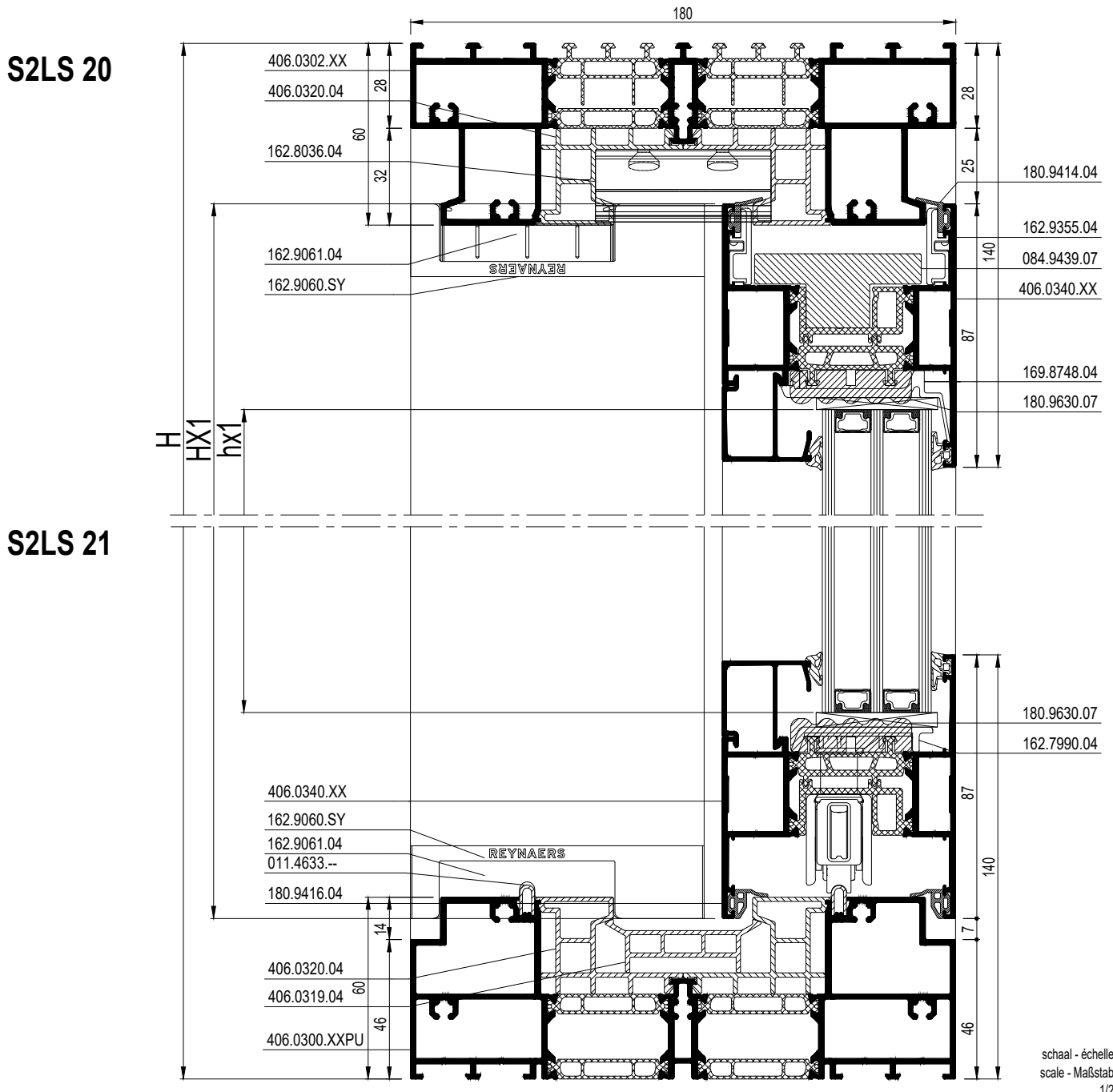







































\*\* VOOR SECUNDAIRE VLEUGEL  
\*\* POUR SEMI-FIXE  
\*\* FOR SECOND VENT  
\*\* FÜR STANDFLÜGEL





































**S2LS 19**





			#	$\leftarrow L_m$
406.0300.XXPU			1	B - 66
406.0302.XX			1	B - 66
406.0325.XX			2	H
406.0319.04			1	B1 - 73.5
			1	(B2 + B3) - 81
			1	B4 - 73.5
406.0320.04			4	B - 66
406.0319.04			1	(B1+B2) - 9.5
			1	(B3+B4) - 89.5
			1	B - 94
406.0326.04			2	H - 120
406.0319.04			1	H - 188 *
			2	H - 120 *
406.0340.XX			4	H - 106
			2	B1 + 3.5 (-20)
			2	B2 + 40 (-20)
			2	B3 + 40 (-20)
			2	B4 + 3.5 (-20)
406.0343.04			3	H - 176
			2	H - 176
030.3613.XX			8	H - 276
			2	B1 - 116.5
			2	B2 - 80
			2	B3 - 80
			2	B4 - 116.5
406.0335.XX			4	H - 146
406.0341.04			4	H - 106
406.0342.XX			4	H - 154
406.0997.XX			1	H - 192
OM0.1505.00			4	 34G.F



BX1 = B1+3.5
BX2 = B2+40
BX3 = B3+54
BX4 = B4+3.5
HX = H-106
bx1 = BX1-136
bx2 = BX2-136
bx3 = BX3-150
bx4 = BX4-136
hx = HX-136

		#
052.5371.--		20
168.8105.00		16
168.5012.--		16
168.8106.00		16
050.5091.--		32
160.8725.--		16
160.8750.--		16
052.5300.--		4 x (H / 300)
050.5074.--		 34G.F
162.7980.04		20
162.7990.04		10
169.8748.04		16
162.9355.04		24
080.9124.SY		2B + 8H
080.9381.04		4H
180.9114.SY		2B + 8H
084.9114.04		2H
080.9724.04		4
084.9440.07		4 x (H - 159)
084.9439.07		B1 - 65
		B2 - 28.5
		B3 - 28.5
		B4 - 65
087.9853.07		6 x (H - 160)
180.9630.07		2B + 8H
Lock set		3
Lock set		1 **
Wheels set		4
162.7930.--		min. 3
162.7940.--		1
162.8036.04		2
052.5309.--		4
162.9060.SY		4
162.9061.04		4
162.8081.04		4
162.8062.04		2
162.8063.04		2
162.9312.04		2
180.9160.04		2B
180.9412.04		8H
180.9414.04		2B
180.9416.04		2B + 6H
180.9493.04		3
062.7715.XX		 34G.F
180.8120.04		1
069.6830.04		 34G.F

\* KNIP IN STUKKEN  
\* COUPE EN MORCEAUX  
\* CUT IN PIECES  
\* IN STUCKE SCHNEIDEN

\*\* VOOR SECUNDAIRE VLEUGEL  
\*\* POUR SEMI-FIXE  
\*\* FOR SECOND VENT  
\*\* FÜR STANDFLÜGEL

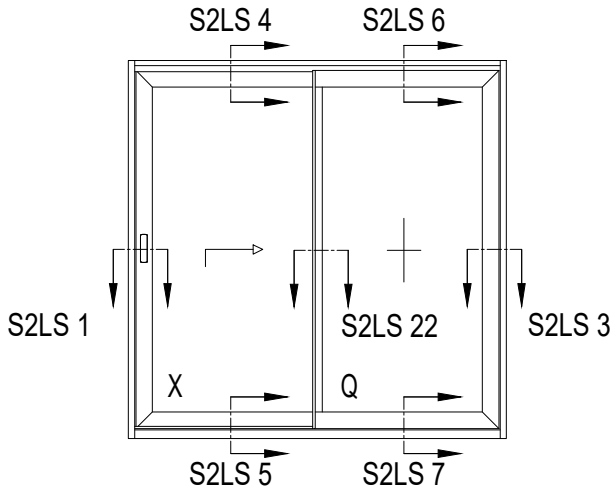



**S2LS 22**

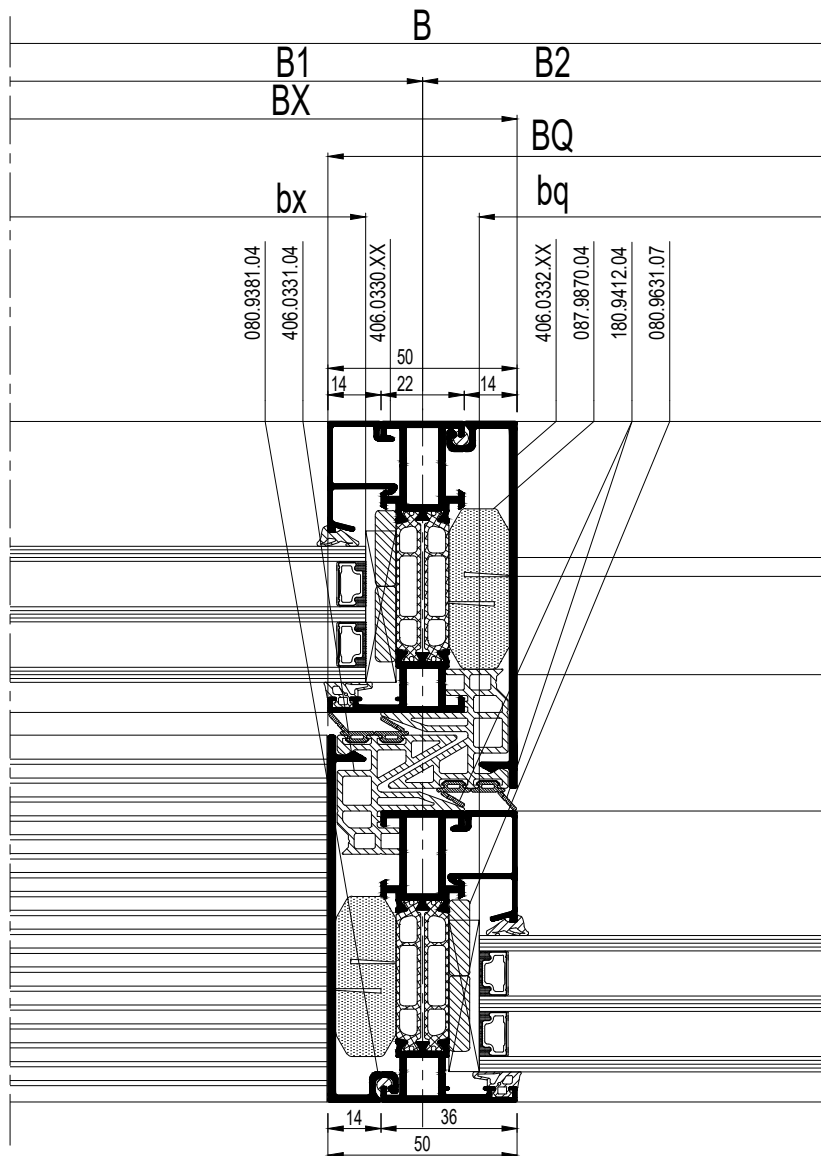

schaal - échelle  
 scale - Maßstab  
 1/2

			#	
406.0300.XXPU			1	B - 66
406.0302.XX			1	B - 66
406.0325.XX			2	H
406.0319.04			1	B2 - 55
406.0320.04			4	B - 66
011.4633.--			1	B - 80
406.0326.04			2	H - 120
406.0324.04			1	H - 120 *
406.0363.XX			1	B1 - 58.5
406.0340.XX			2	H - 106
			2	B1 - 29
			2	B2 - 29
406.0343.04			1	H - 176
030.3613.XX			2	H - 276
			2	B1 - 111
			2	B2 - 111
002.0687.XX			2	H - 276
406.0330.XX			2	H - 226
406.0331.04			2	H - 106
406.0332.XX			2	H - 154
0M0.1505.00			1	34G.F

\* KNIP IN STUKKEN  
 \* COUPE EN MORCEAUX  
 \* CUT IN PIECES  
 \* IN STUCKE SCHNEIDEN

BX = B1-15
BQ = B2-15
HX = H-106
HQ = H-106
bx = BX-108
bq = BQ-108
hx = HX-136
hq = HQ-136

		#
052.5371.--		20
168.8105.00		4
168.5012.--		4
168.8106.00		4
050.5091.--		8
068.8932.00		4
168.8727.00		4
050.5083.--		4
168.5012.--		2
168.8688.04		4
160.8725.--		8
160.8750.--		4
052.5327.--		2 x (H / 300)
162.7980.04		5
162.7990.04		5
169.8748.04		10
162.8170.04		7
050.5081.--		4
052.5305.--		5
162.9355.04		12
162.8172.04		1
080.9124.SY		2B + 4H
080.9381.04		2H
180.9114.SY		2B + 4H
080.9724.04		4
084.9440.07		B2 - 115
		B2 - 250 *
		H - 255 *
084.9439.07		B1 - 60.5
087.9870.07		H - 159
		H - 172
087.9853.07		2 x (H - 160)
180.9630.07		2B + 2H
080.9631.07		4H
Lock set		1
Wheels set		1
162.7930.--		min. 1
162.8036.04		1
052.5309.--		2
162.9090.SY		2
162.9091.04		2
162.8081.04		4
162.8073.04		2
162.9312.04		2
180.9160.04		B
180.9493.04		2
069.6830.04		34G.F
180.9416.04		2B + 4H
062.7715.XX		34G.F
180.9412.04		B1 + 4H
180.9414.04		2B

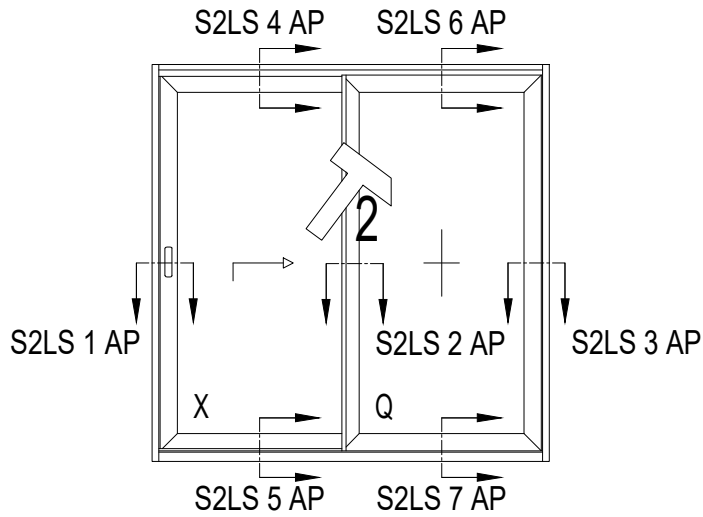

## S2LS 1 AP

## S2LS 2 AP

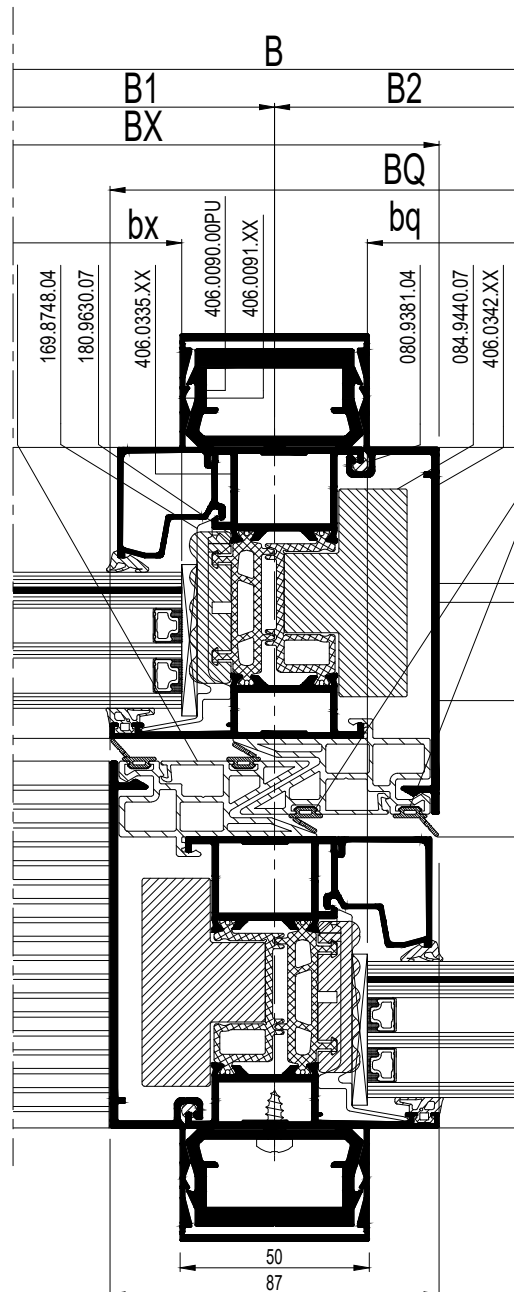
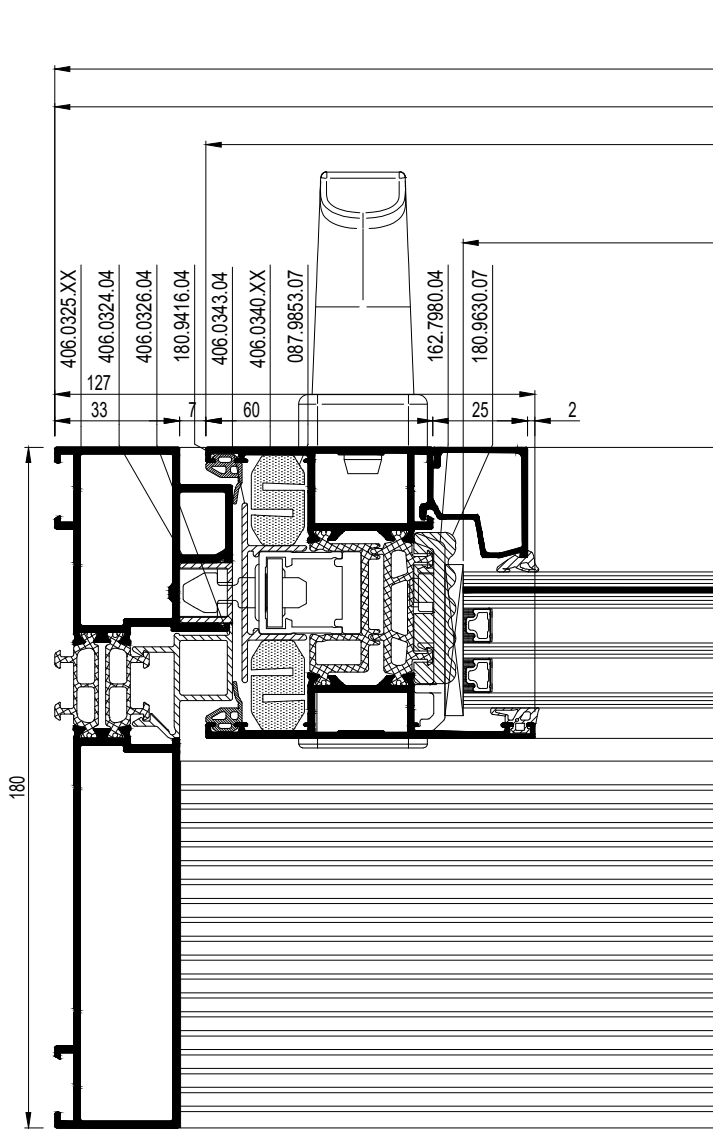

schaal - échelle  
 scale - Maßstab  
 1/2

### S2LS 3 AP

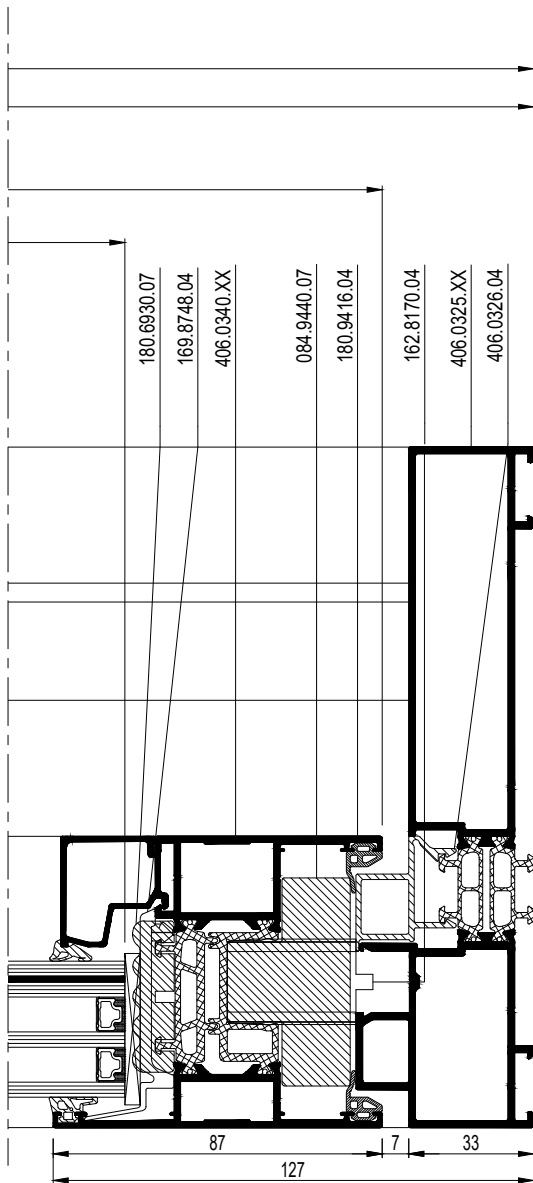

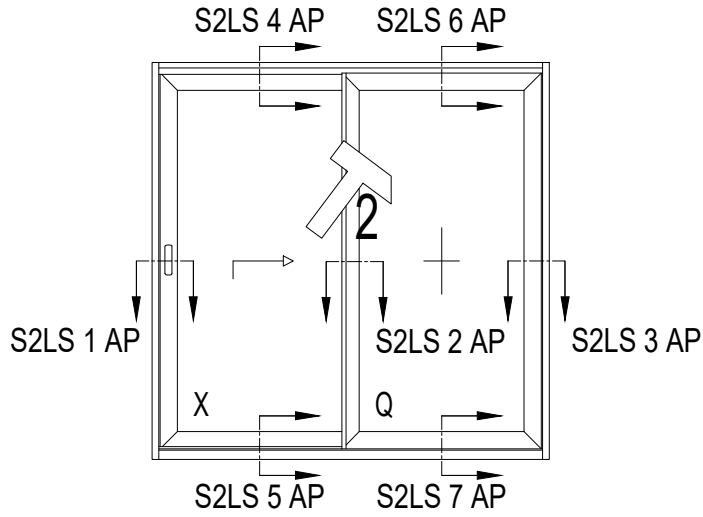

## S2LS 4 AP

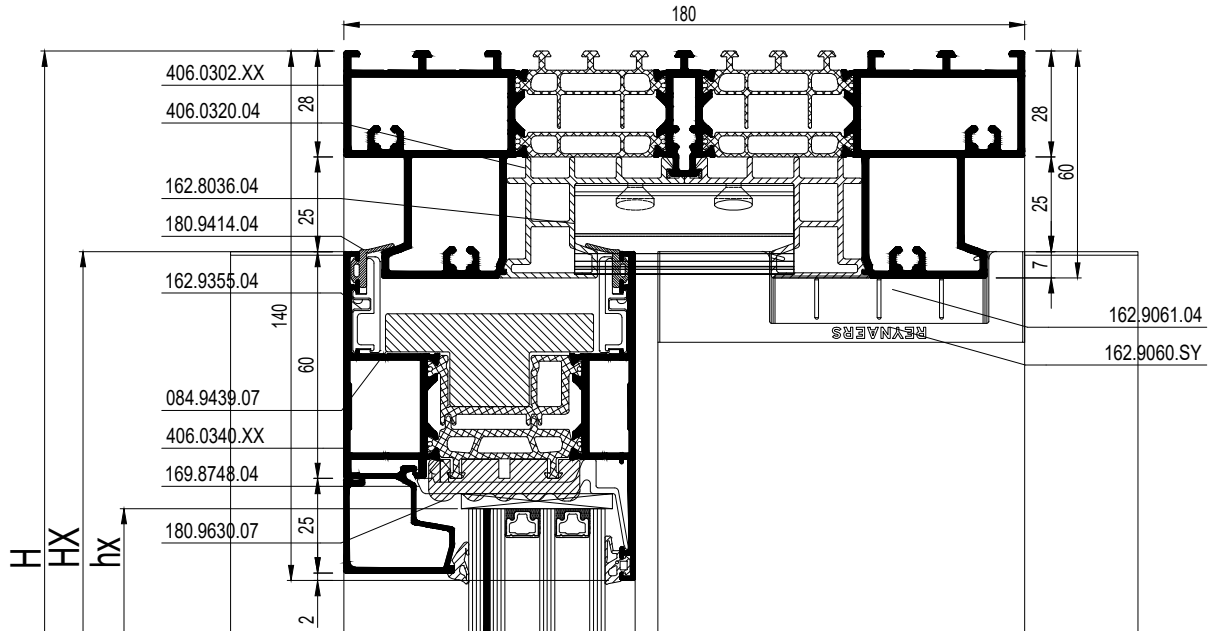

## S2LS 5 AP

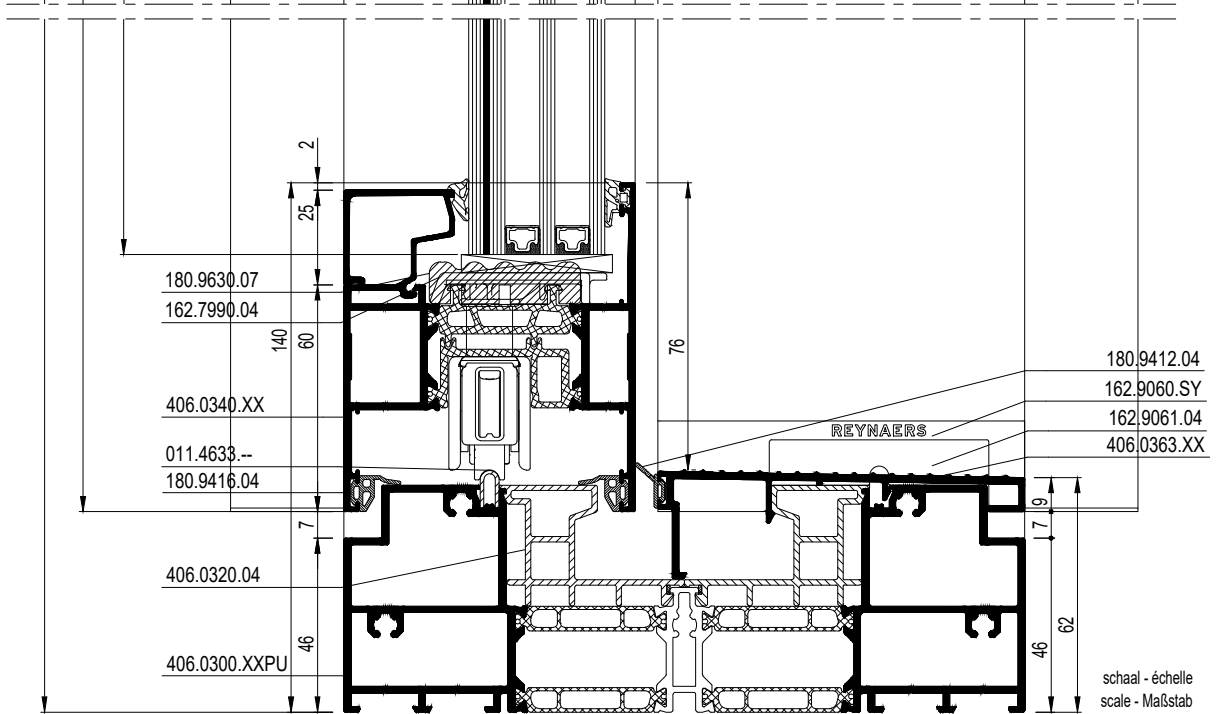

**S2LS 6  
 AP**

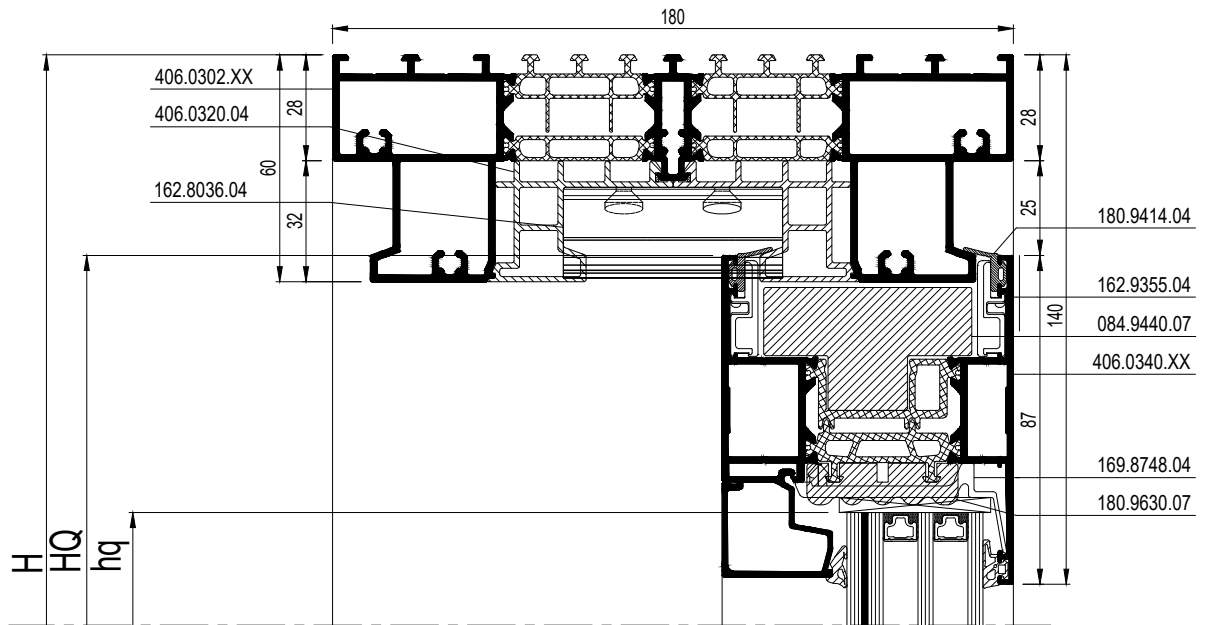

**S2LS 7  
 AP**

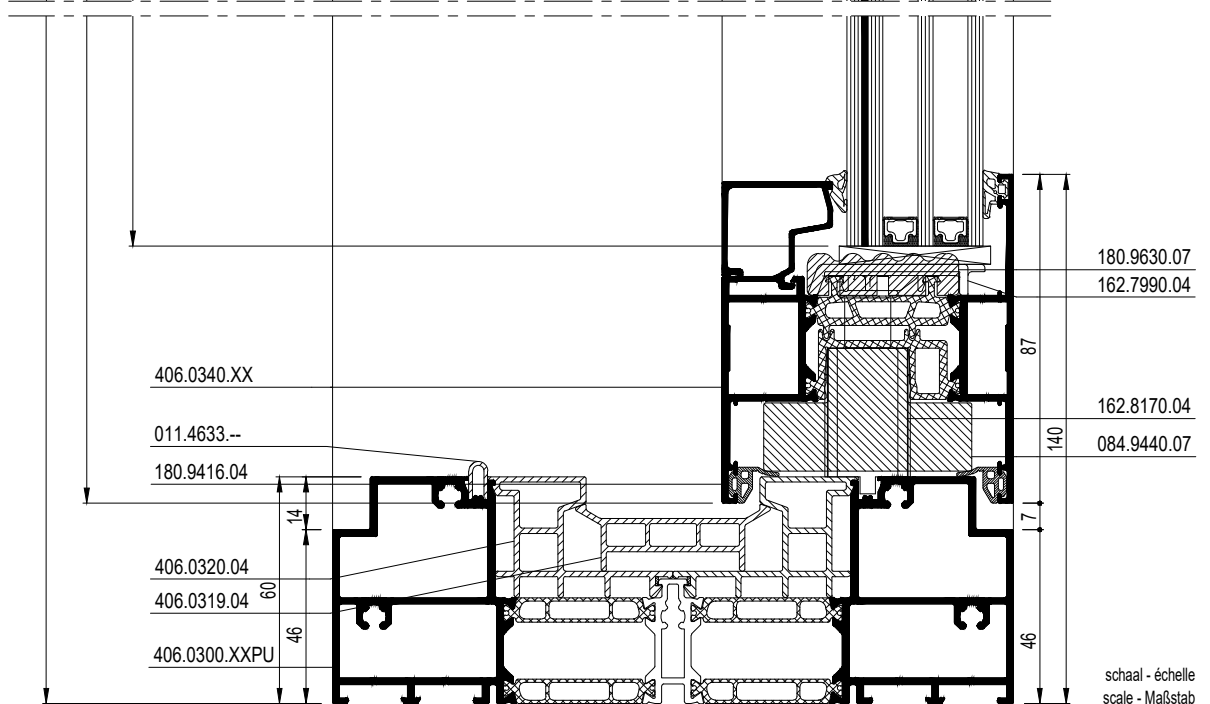

schaal - échelle  
 scale - Maßstab  
 1/2

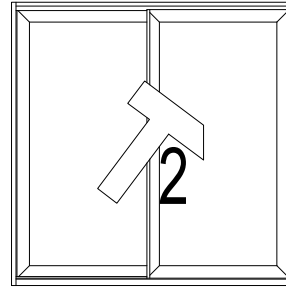
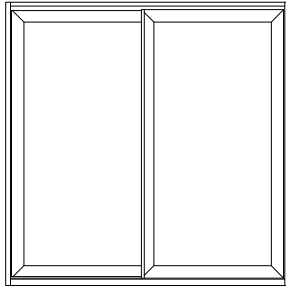

2-RAIL XQ - STANDARD CHICANE

AP 2-RAIL XQ - STANDARD CHICANE

			#	← Lm →
030.3613.XX			4	H - 276
			2	B1 - 116.5
			2	B2 - 116.5







			#	← Lm →
130.3653.XX			4	H - 276
			2	B1 - 116.5
			2	B2 - 116.5
406.0090.00PU			2	H-108
406.0091.XX			2	H-108

		#
084.9439.07		B1 - 65
162.7930.--		min. 1
169.8748.04		10
162.7980.04		5

		#
084.9439.07		B1 - 200
162.7930.--		2
169.8748.04		12
050.5387.--		9 2 / Lock point
050.5080.--		8
050.5081.--		8
162.7931.--		34G.F
169.6547.00		min. 6
052.5316.--		min. 18
062.8158.XX		1







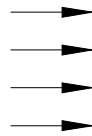





EXTRA

### 2-RAIL - STANDARD CHICANE

		#
084.9439.07		B1 - 65
162.7930.--		min. 1 / X-Vent
169.8748.04		x
162.7980.04		5 / X-Vent









### AP 2-RAIL - STANDARD CHICANE

		#
084.9439.07		B1 - 200
162.7930.--		2 / X-Vent
169.8748.04		x + 2 / X-Vent
050.5387.--		9 / X-Vent
		2 / Lock point
050.5080.--		8 / X-Vent
050.5081.--		8 / X-Vent
162.7931.--		 34G.F
169.6547.00		min. 6 / Vent
052.5316.--		min. 18 / Vent
062.8158.XX		1 / 2-X-Vents







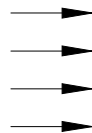





EXTRA

### 2-RAIL - SLIM CHICANE

		#
084.9439.07		B1 - 65
162.7930.--		min. 1 / X-Vent
169.8748.04		x
162.7980.04		5 / X-Vent



### AP 2-RAIL - SLIM CHICANE

		#
084.9439.07		B1 - 200
162.7930.--		2 / X-Vent
169.8748.04		x + 2 / X-Vent
050.5387.--		9 / X-Vent
		2 / Lock point
050.5080.--		8 / X-Vent
050.5081.--		8 / X-Vent
162.7931.--		 34G.F
169.6547.00		min. 4 / Vent
052.5316.--		min. 12 / Vent
062.8158.XX		1 / 2-X-Vents

EXTRA

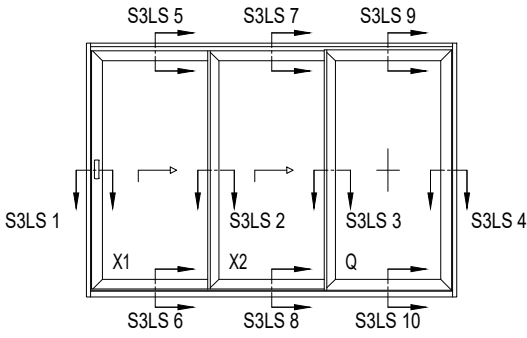

S3LS 1

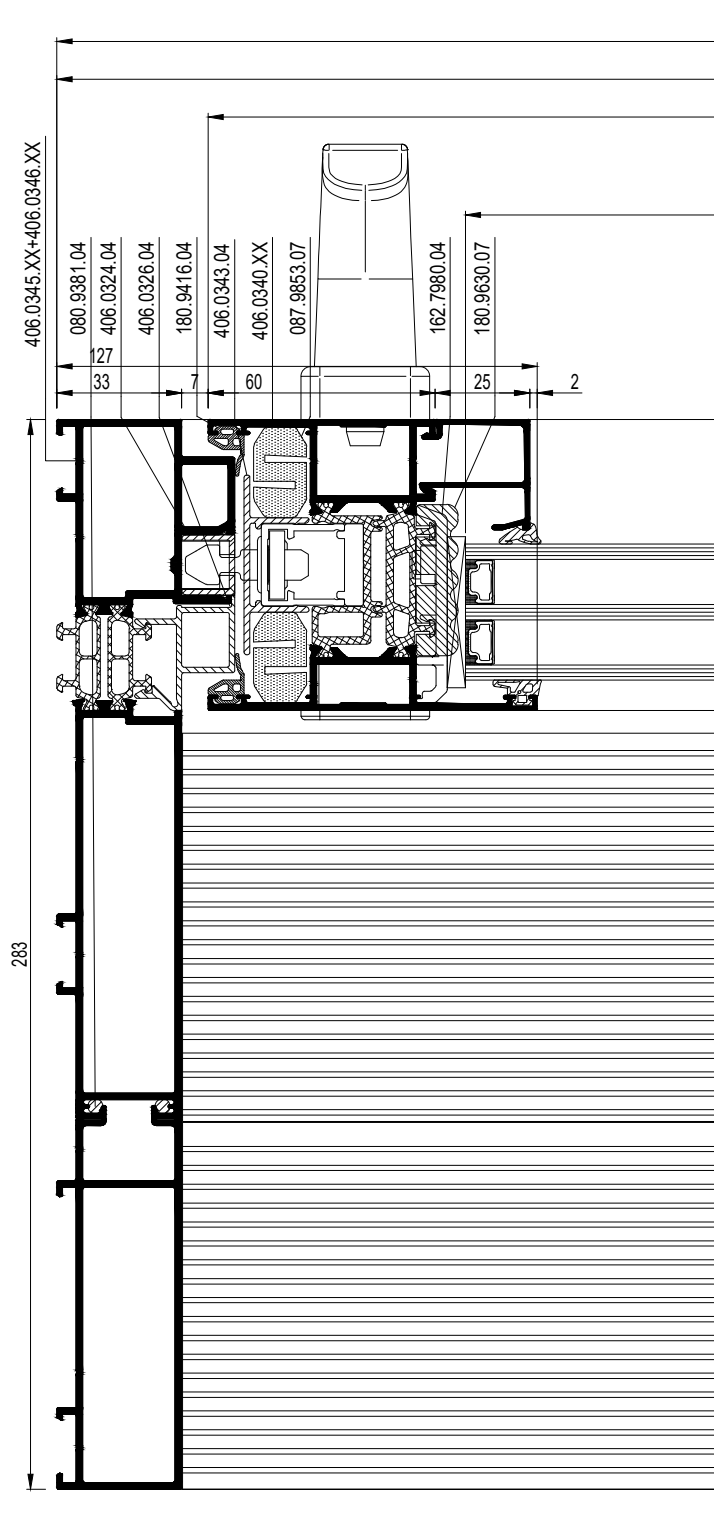

S3LS 2

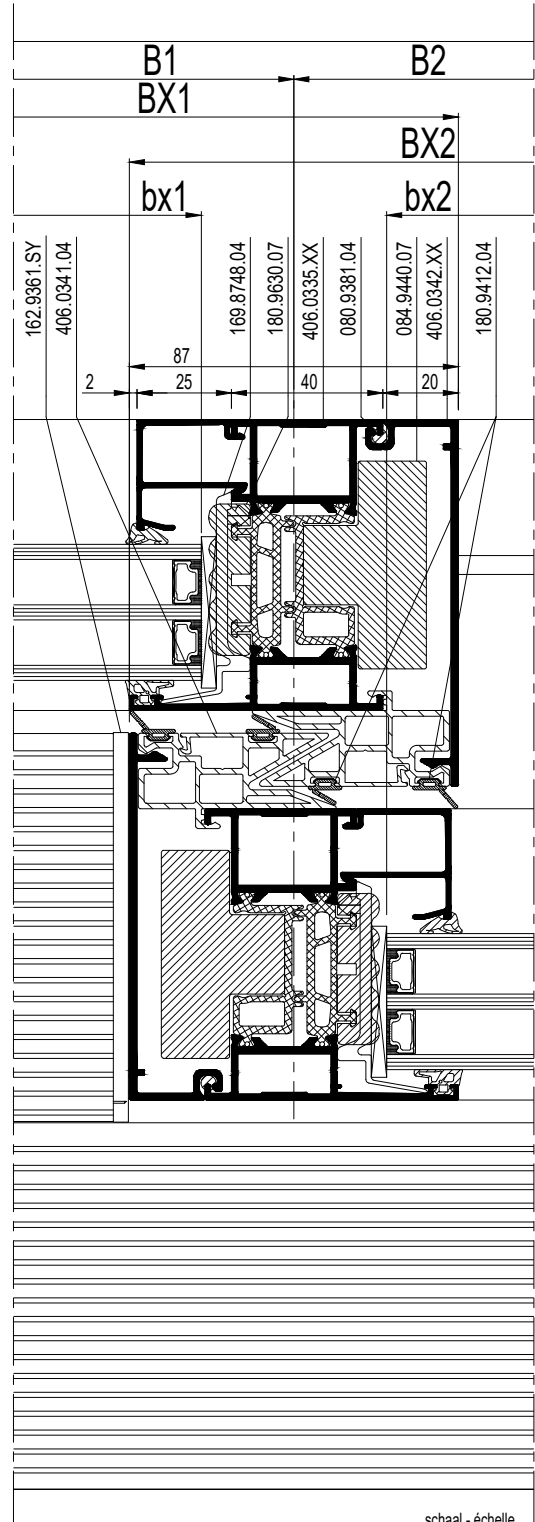

schaal - échelle  
 scale - Maßstab  
 1/2

S3LS 3

S3LS 4

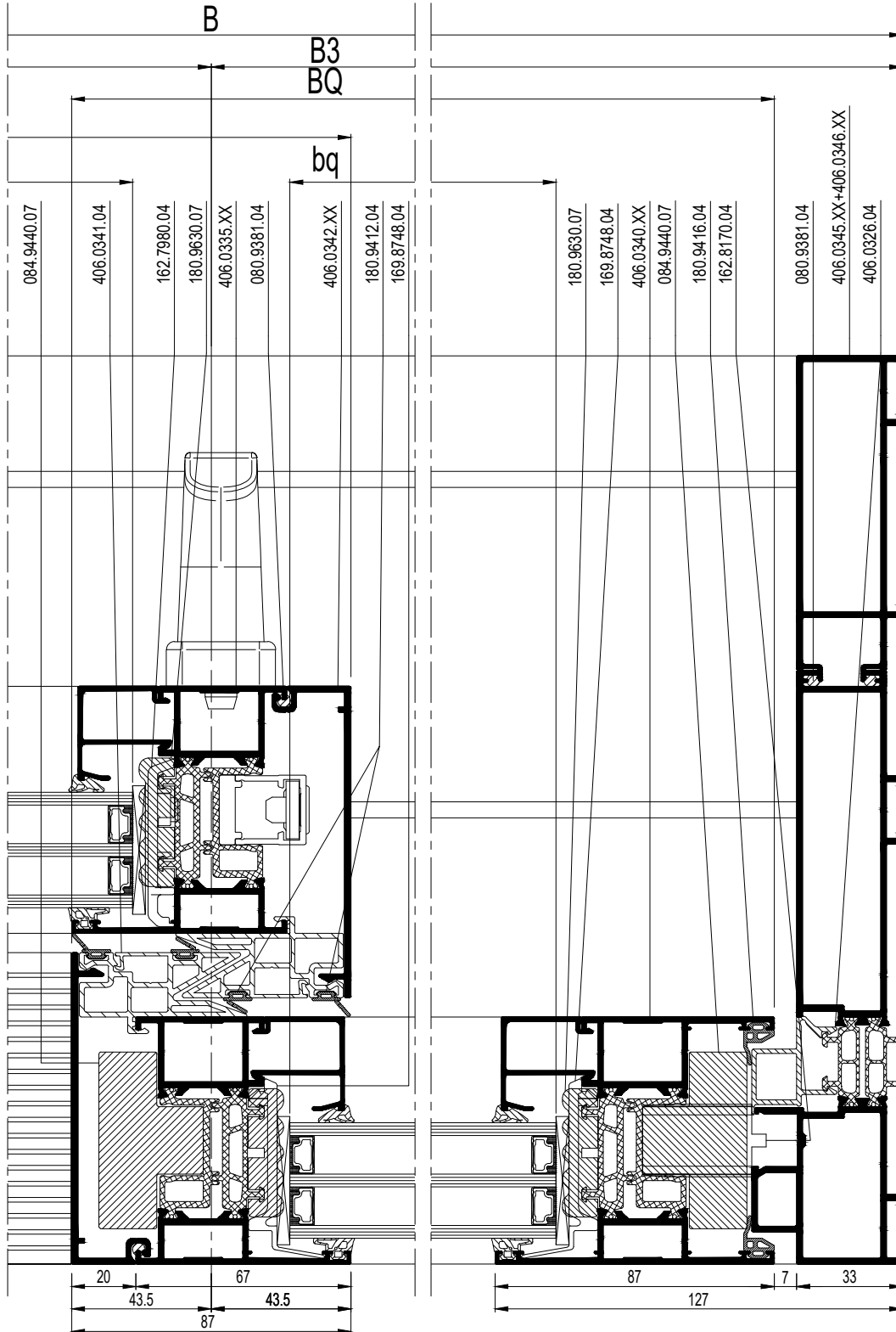

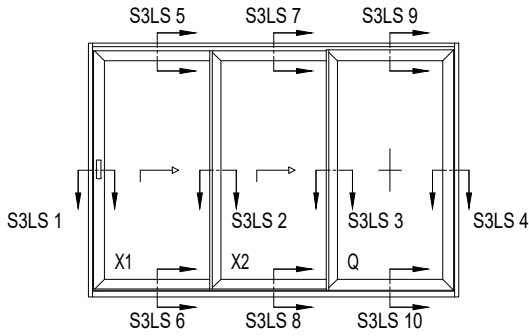

## S3LS 5

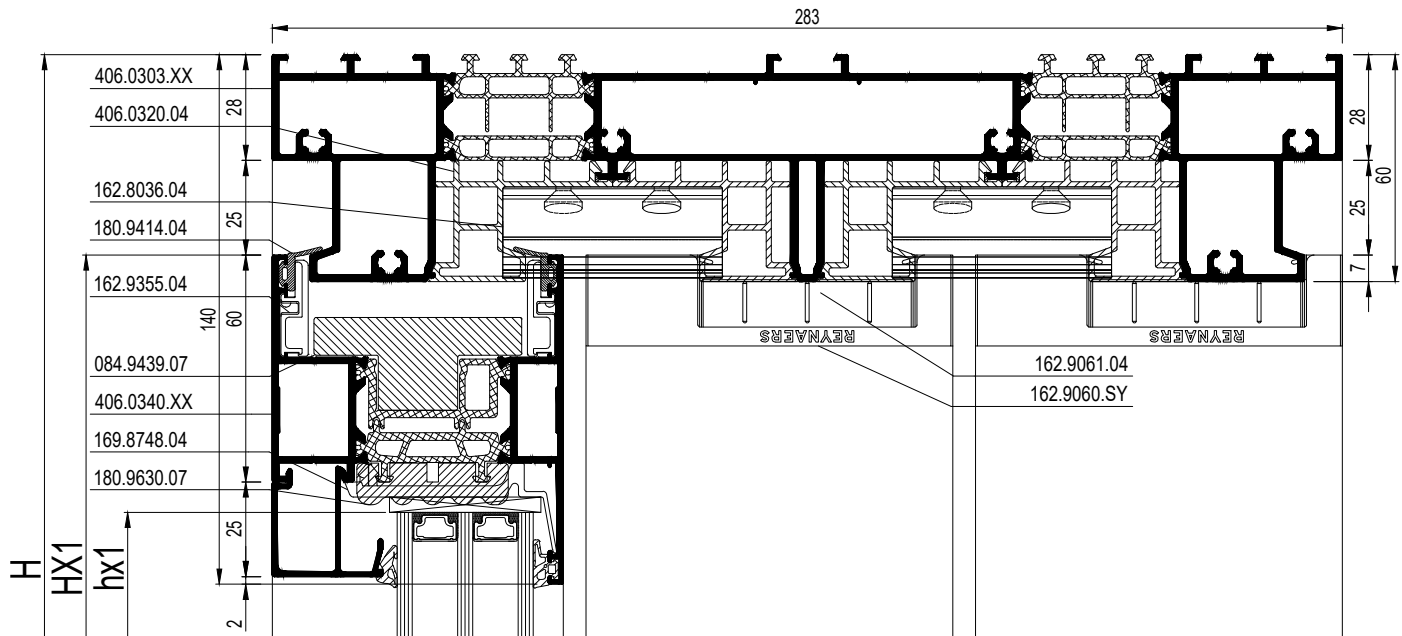

## S3LS 6

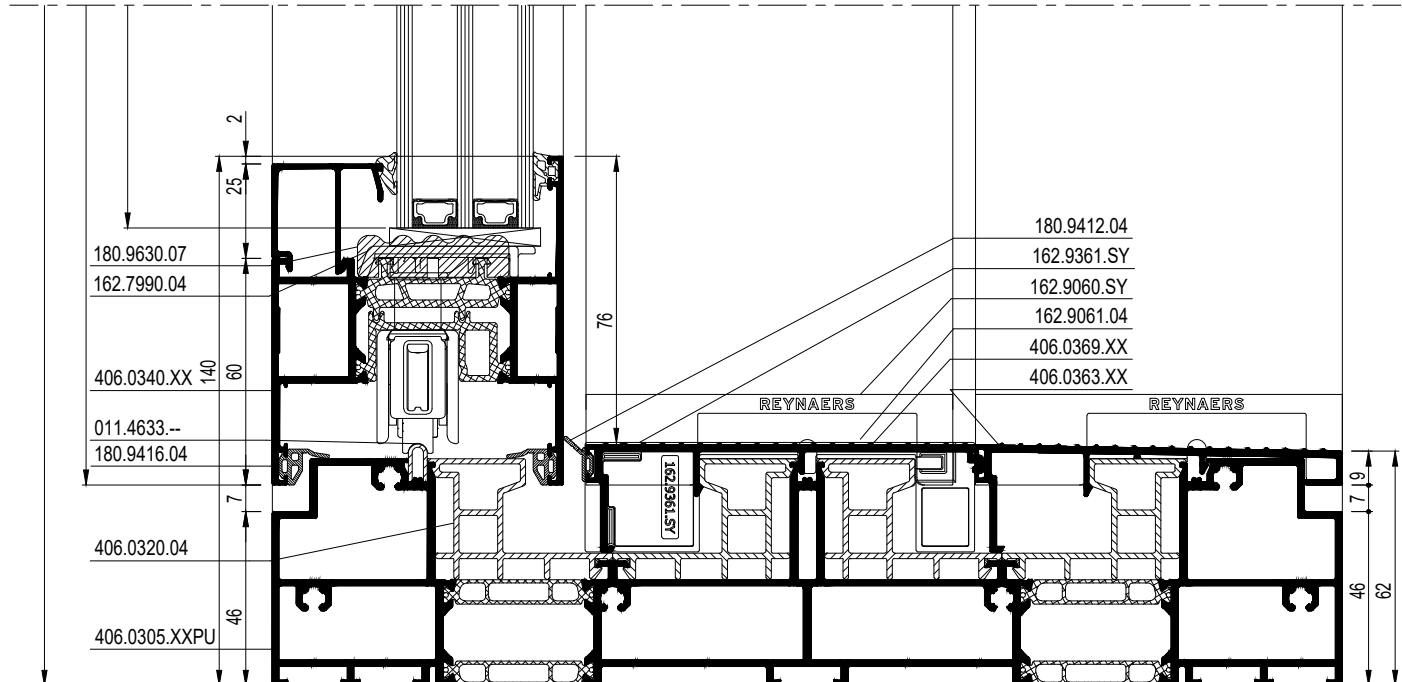

schaal - échelle  
 scale - Maßstab  
 1/2

S3LS 7

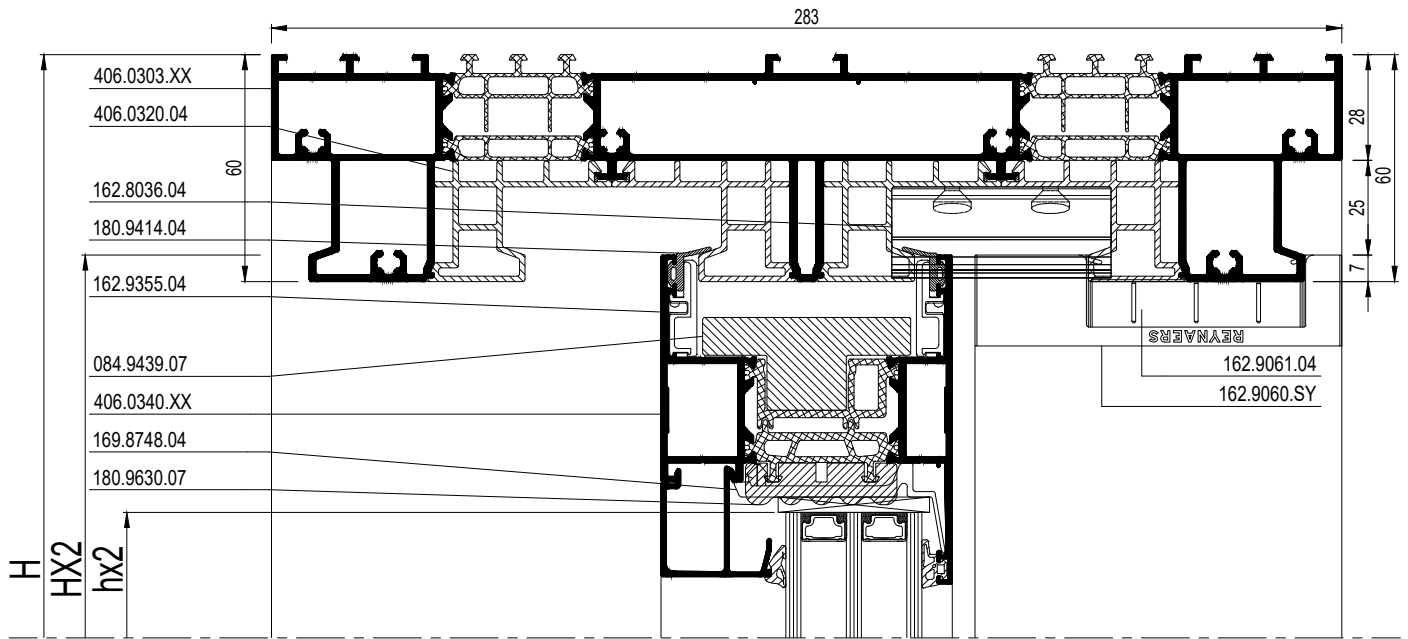

S3LS 8

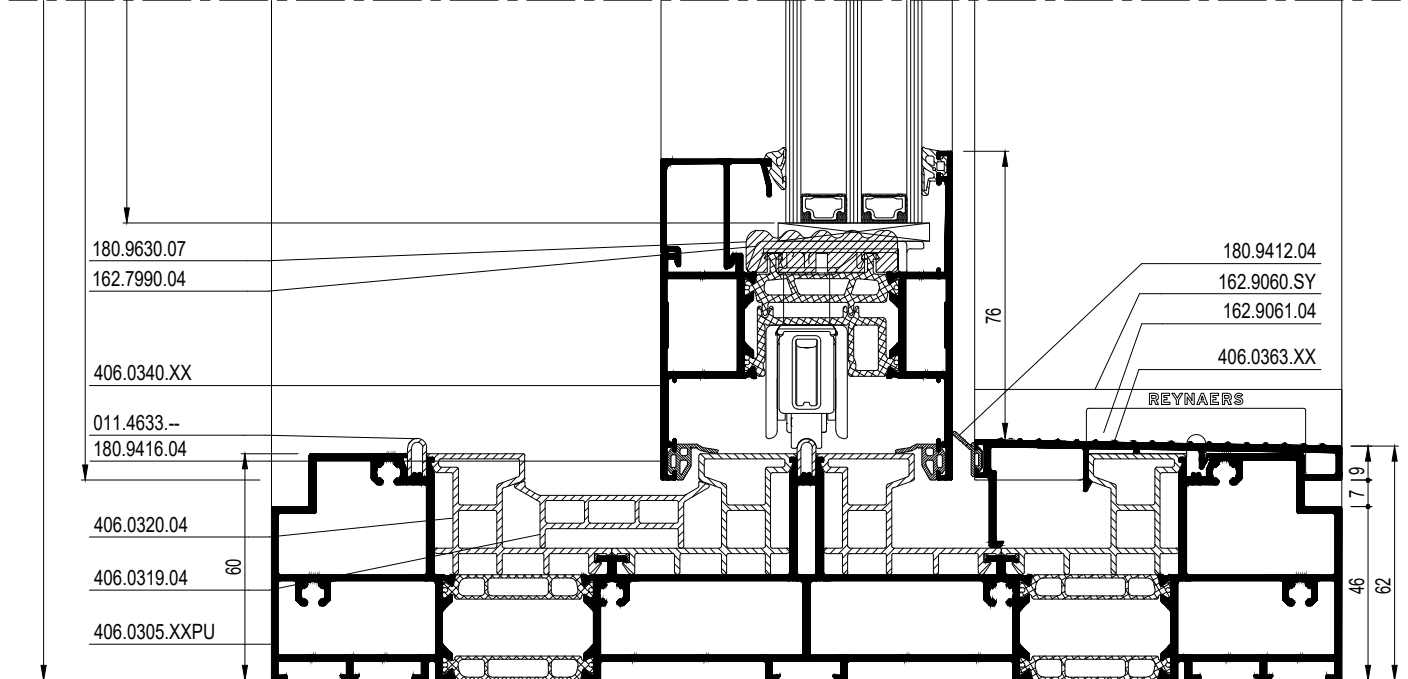

schaal - échelle  
 scale - Maßstab  
 1/2

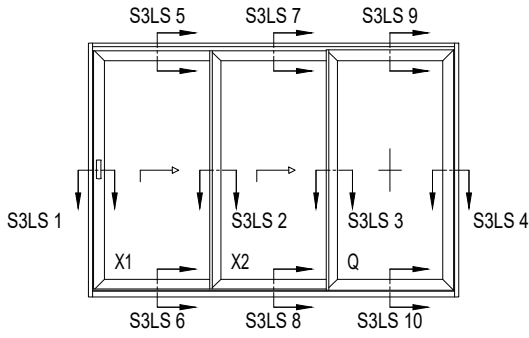

## S3LS 9

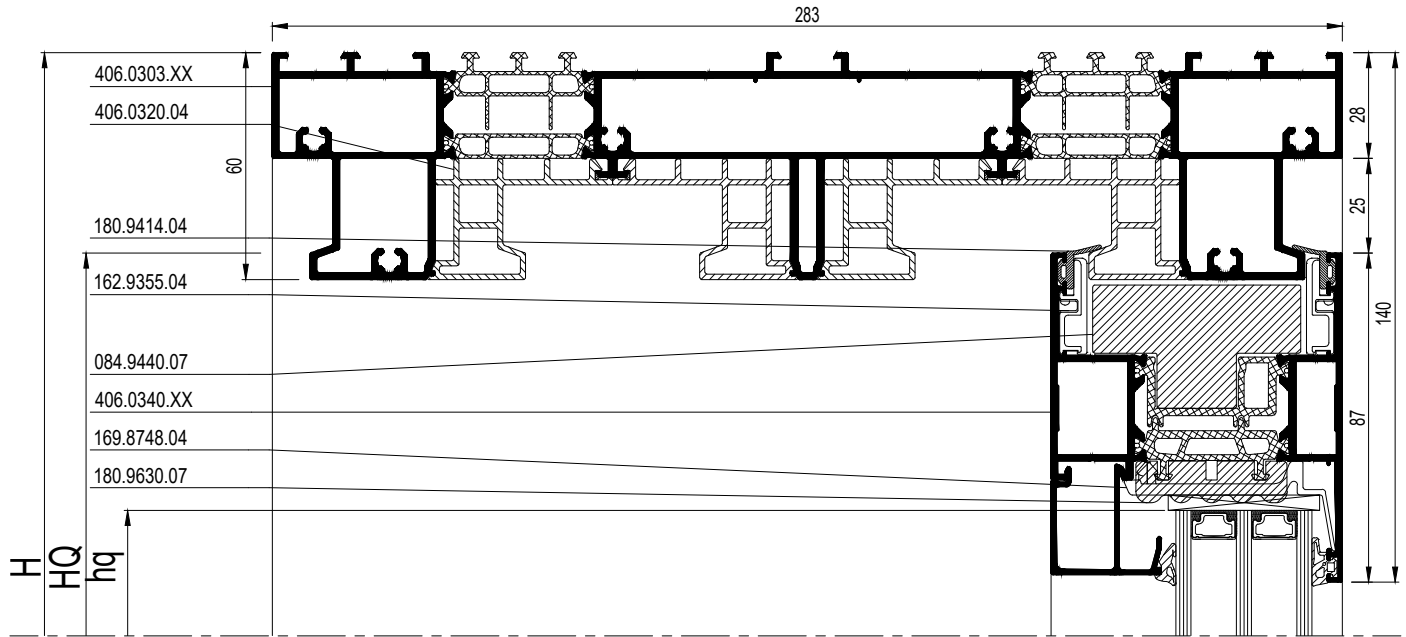

## S3LS 10

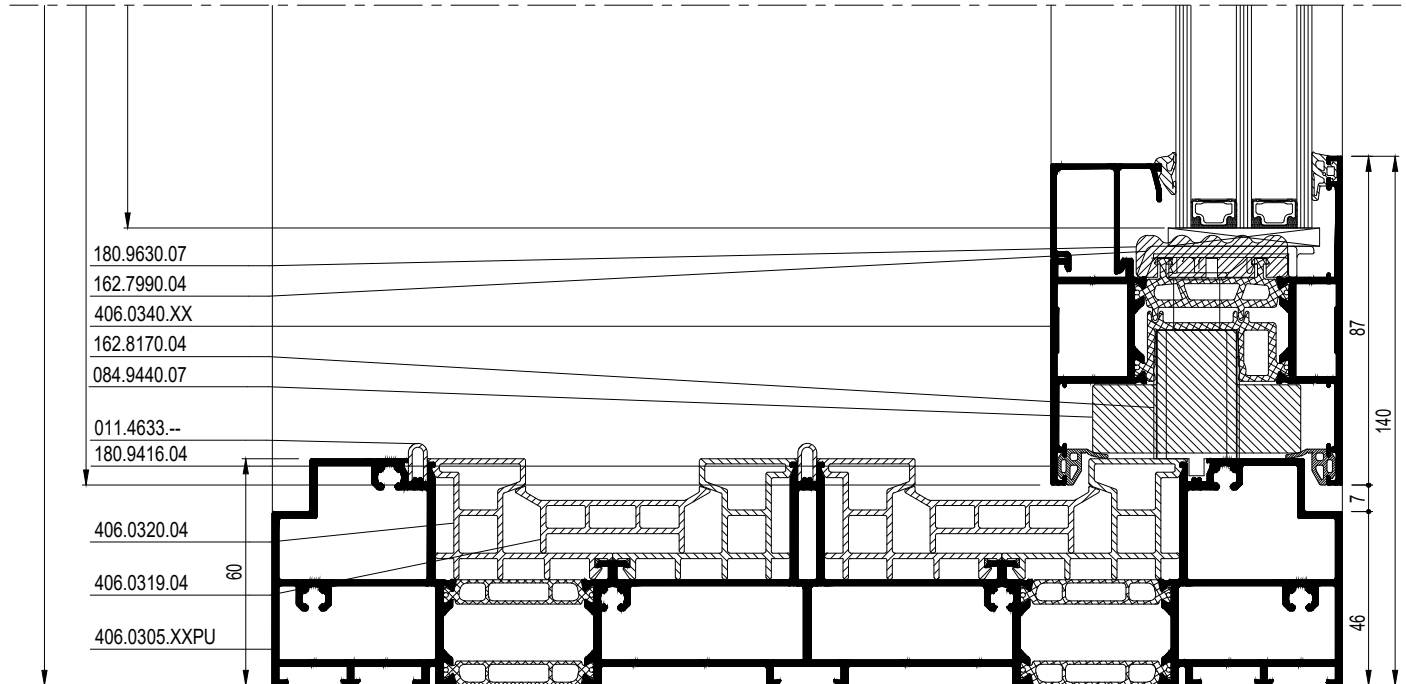

schaal - échelle  
 scale - Maßstab  
 1/2

			#	$\leftarrow L_m$
406.0305.XXPU			1	B - 66
406.0303.XX			1	B - 66
406.0345.XX			2	H
406.0346.XX			2	H
406.0319.04			1	B2 + B3 - 73.5
			1	B3 - 73.5
406.0320.04			8	B - 66
011.4633.--			1	B - 80
			1	B2 + B3 + 10.5
406.0326.04			2	H - 120
406.0324.04			1	H - 120 *
406.0363.XX			1	B1 + B2 - 77
406.0369.XX			1	B1 - 81
406.0340.XX			2	H - 106
			2	B1 + 3.5 (-20)
			2	(-20)B2+87(-20)
			2	B3 + 3.5 (-20)
406.0343.04			1	H - 176
030.3613.XX			6	H - 276
			2	B1 - 116.5
			2	B2 - 33
			2	B3 - 116.5
406.0335.XX			4	H - 146
406.0341.04			4	H - 106
406.0342.XX			4	H - 154
0M0.1505.00			2	34G.F

\* KNIP IN STUKKEN  
\* COUPE EN MORCEAUX  
\* CUT IN PIECES  
\* IN STUCKE SCHNEIDEN

BX1 = B1+3.5
BX2 = B2+87
BQ = B3+3.5
HX = H-106
HQ = H-106
bx1 = BX-136
bx2 = BX-136
bq = BQ-136
hx = HX-136
hq = HQ-136

		#
052.5371.--		24
168.8105.00		12
168.5012.--		12
168.8106.00		12
050.5091.--		24
160.8725.--		8
160.8750.--		12
052.5300.--		4 x (H / 300)
162.7980.04		9
162.7990.04		7
169.8748.04		14
162.8170.04		7
050.5081.--		4
052.5305.--		5
162.9355.04		18
162.8172.04		1
080.9124.SY		2B + 6H
080.9381.04		8H
180.9114.SY		2B + 6H
162.8084.04		4
084.9440.07		B3 - 119.5
		B3 - 254.5 *
		2 x (H - 159)
		H - 185
		H - 255 *
084.9439.07		B1 - 65
		B2 + 18.5
087.9853.07		2 x (H - 160)
180.9630.07		2B + 6H
Lock set		2
Wheels set		2
162.7930.--		min. 1
162.8036.04		2
052.5309.--		4
162.9060.SY		4
162.9061.04		4
162.8081.04		4
162.8063.04		4
162.9335.04		2
180.9160.04		B + (B2+B3)
180.9412.04		B1+B2+8H
180.9414.04		2B
180.9416.04		2B + 4H
180.9493.04		2
062.7715.XX		34G.F
069.6830.04		34G.F
162.9361.SY		1

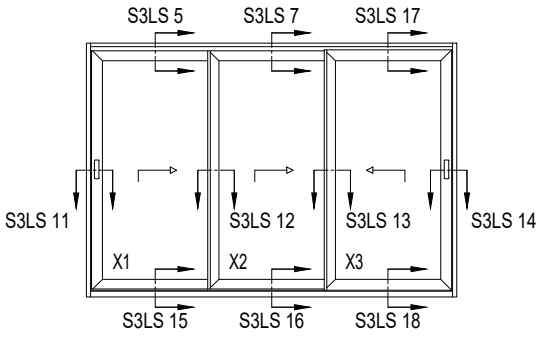

S3LS 11

S3LS 12

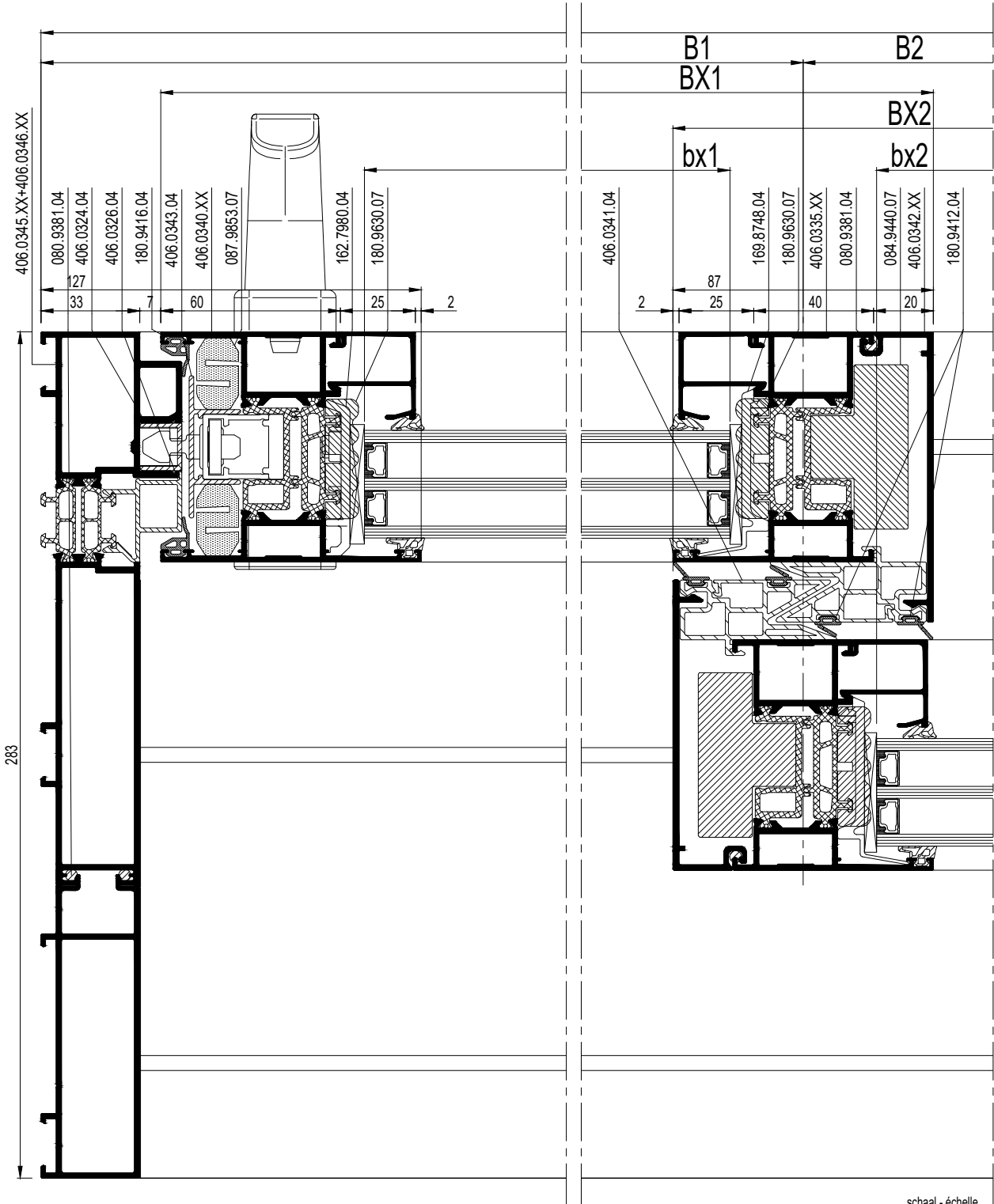

schaal - échelle  
 scale - Maßstab  
 1/2

S3LS 13

S3LS 14

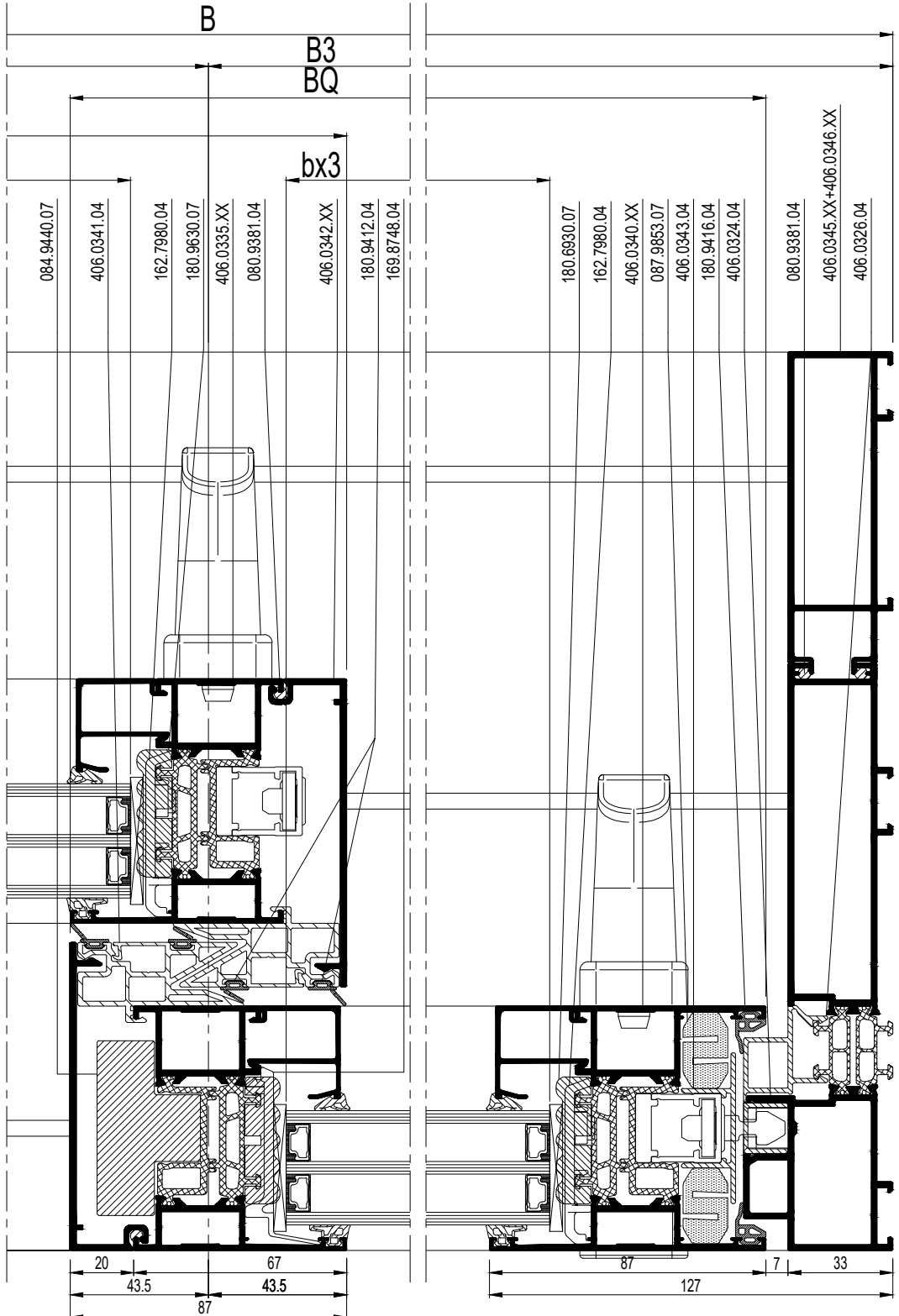

E

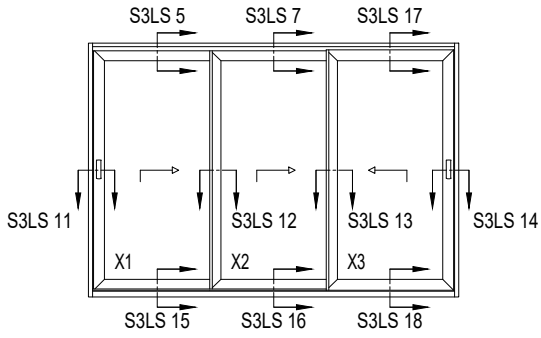

## S3LS 15

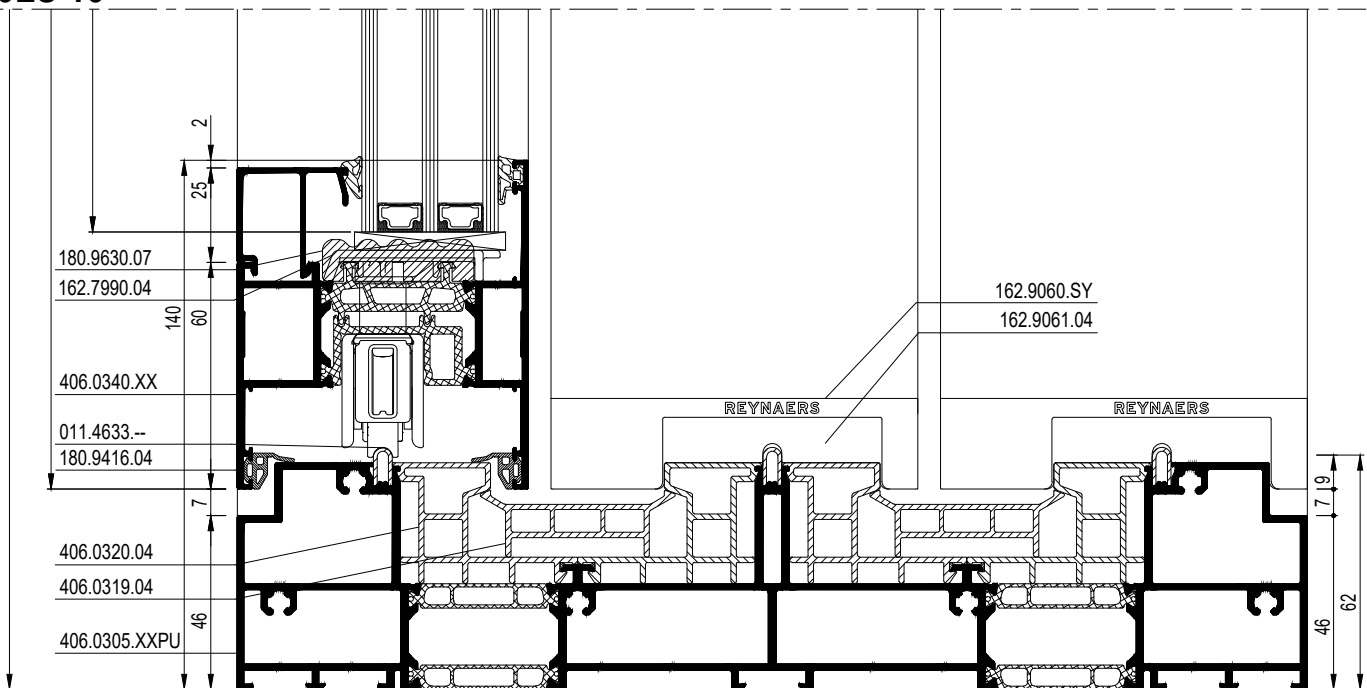

schaal - échelle  
 scale - Maßstab  
 1/2

S3LS 16

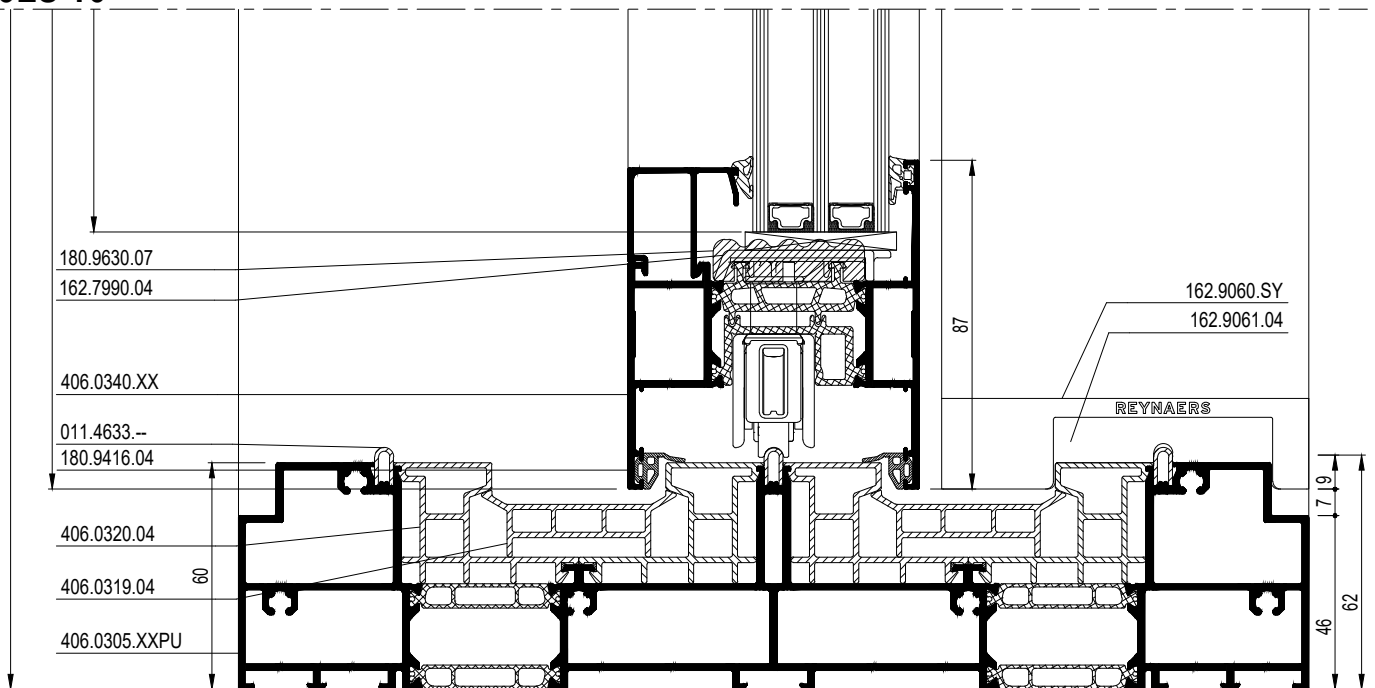

schaal - échelle  
scale - Maßstab  
1/2

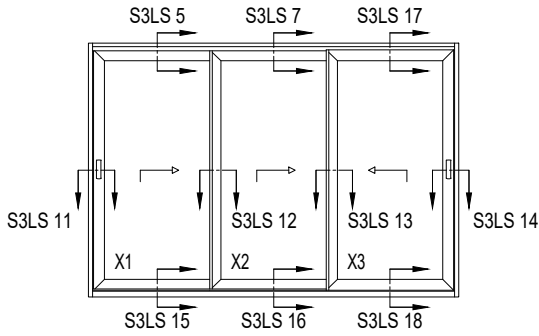

S3LS 17

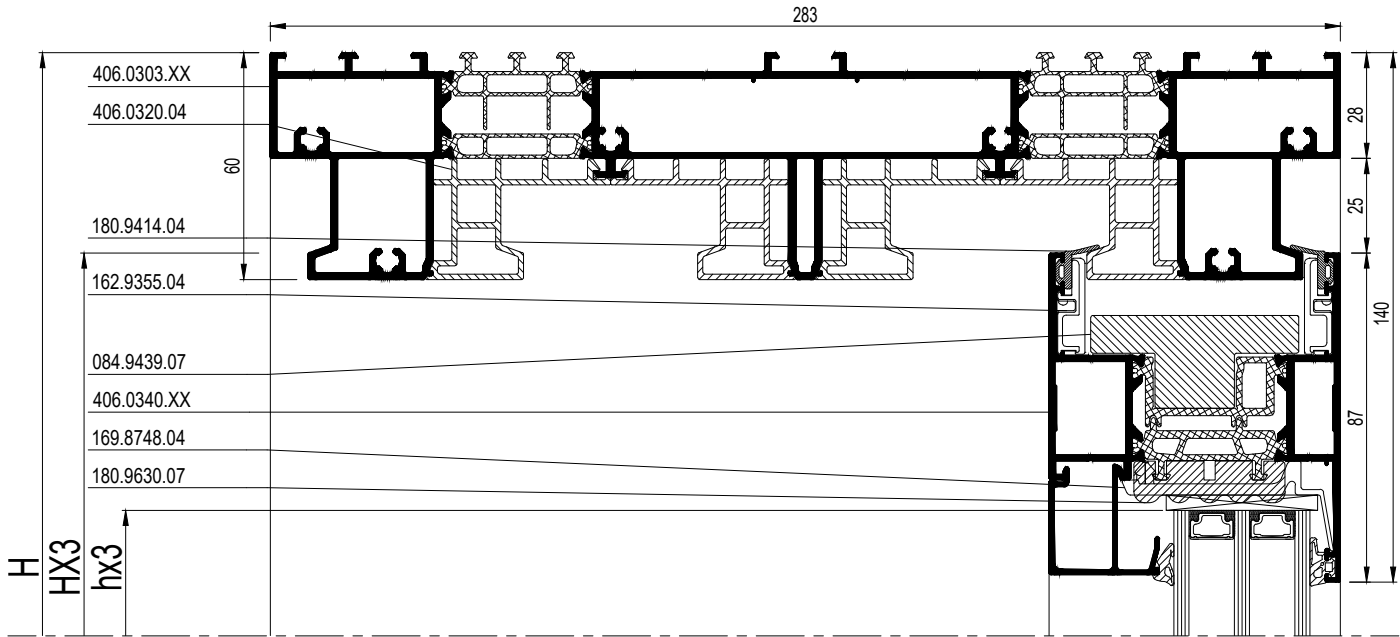

S3LS 18

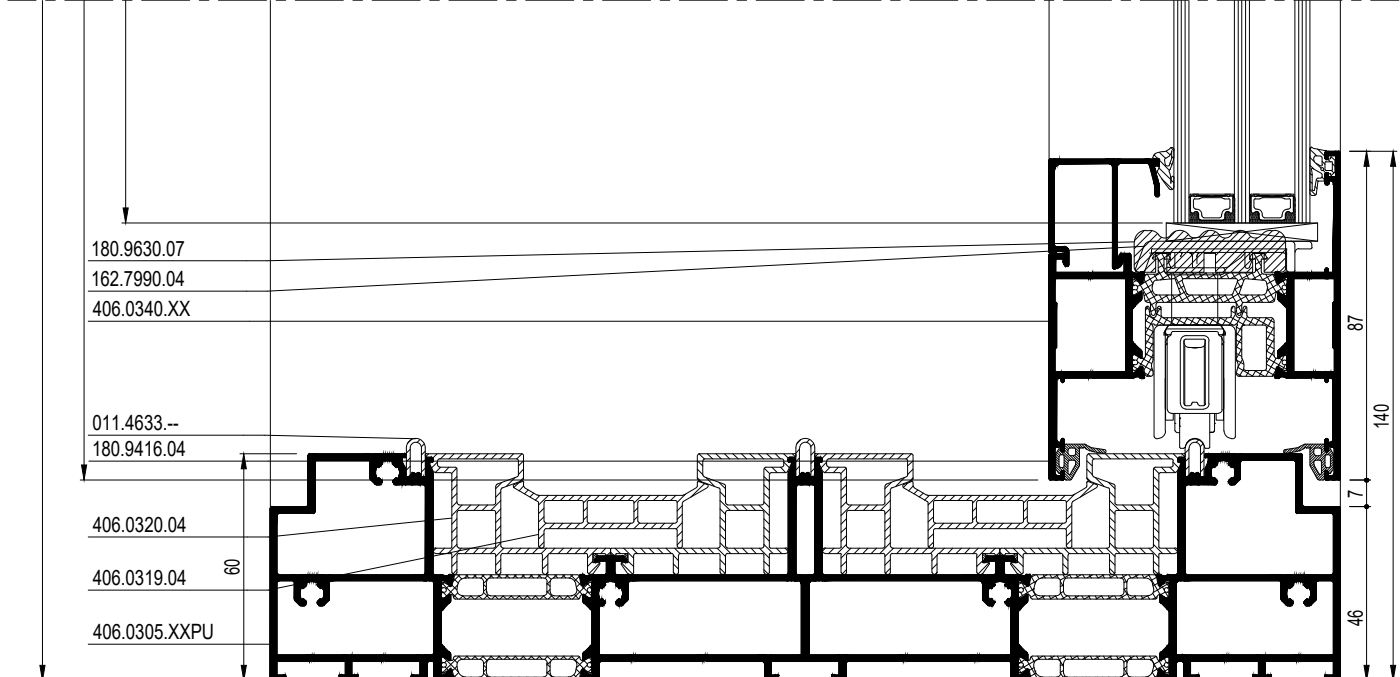

schaal - échelle  
 scale - Maßstab  
 1/2

			#	$L_m$
406.0305.XXPU			1	B - 66
406.0303.XX			1	B - 66
406.0345.XX			2	H
406.0346.XX			2	H
406.0319.04			1	B1 - 73.5
			1	B2 + B3 - 73.5
			1	B1 + B2 - 73.5
			1	B3 - 73.5
406.0320.04			8	B - 66
011.4633.--			2	B - 80
			1	B - 66
406.0326.04			2	H - 120
406.0324.04			2	H - 120 *
406.0340.XX			2	H - 106
			2	B1 + 3.5 (-20)
			2	(-20)B2+87(-20)
			2	B3 + 3.5 (-20)
406.0343.04			2	H - 176
030.3613.XX			6	H - 276
			2	B1 - 116.5
			2	B2 - 33
			2	B3 - 116.5
406.0335.XX			4	H - 146
406.0341.04			4	H - 106
406.0342.XX			4	H - 154
OM0.1505.00			3	34G.F

\* KNIP IN STUKKEN  
\* COUPE EN MORCEAUX  
\* CUT IN PIECES  
\* IN STUCKE SCHNEIDEN

BX1 = B1+3.5
BX2 = B2+87
BQ = B3+3.5
HX = H-106
HQ = H-106
bx1 = BX-136
bx2 = BX-136
bq = BQ-136
hx = HX-136
hq = HQ-136

		#
052.5371.--		24
168.8105.00		12
168.5012.--		12
168.8106.00		12
050.5091.--		24
160.8725.--		8
160.8750.--		12
052.5300.--		4 x (H / 300)
162.7980.04		14
162.7990.04		8
169.8748.04		12
162.9355.04		18
080.9124.SY		2B + 6H
080.9381.04		8H
180.9114.SY		2B + 6H
162.8084.04		4
084.9440.07		3 x (H - 159)
084.9439.07		B1-65
		B2+18.5
		B3-65
087.9853.07		4 x (H - 160)
180.9630.07		2B + 6H
Lock set		3
Wheels set		3
162.7930.--		min. 2
162.8036.04		2
052.5309.--		4
162.9060.SY		4
162.9061.04		4
162.8081.04		4
162.8063.04		4
162.9335.04		2
180.9160.04		3B
180.9412.04		8H
180.9414.04		2B
180.9416.04		2B + 4H
180.9493.04		2
062.7715.XX		34G.F
069.6830.04		34G.F

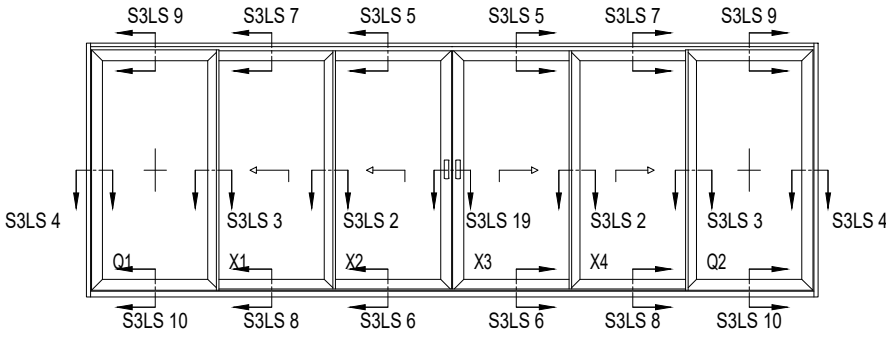

BQ1 = B1+3.5
BX1 = B2+87
BX2 = B3+40
BX3 = B4+54
BX4 = B5+87
BQ2 = B6+3.5
HX = H-106
HQ = H-106
bq1 = BQ1-136
bx1 = BX1-136
bx2 = BX2-136
bx3 = BX3-150
bx4 = BX4-136
bq2 = BQ2-136
hx = HX-136
hq = HQ-136

## S3LS 19

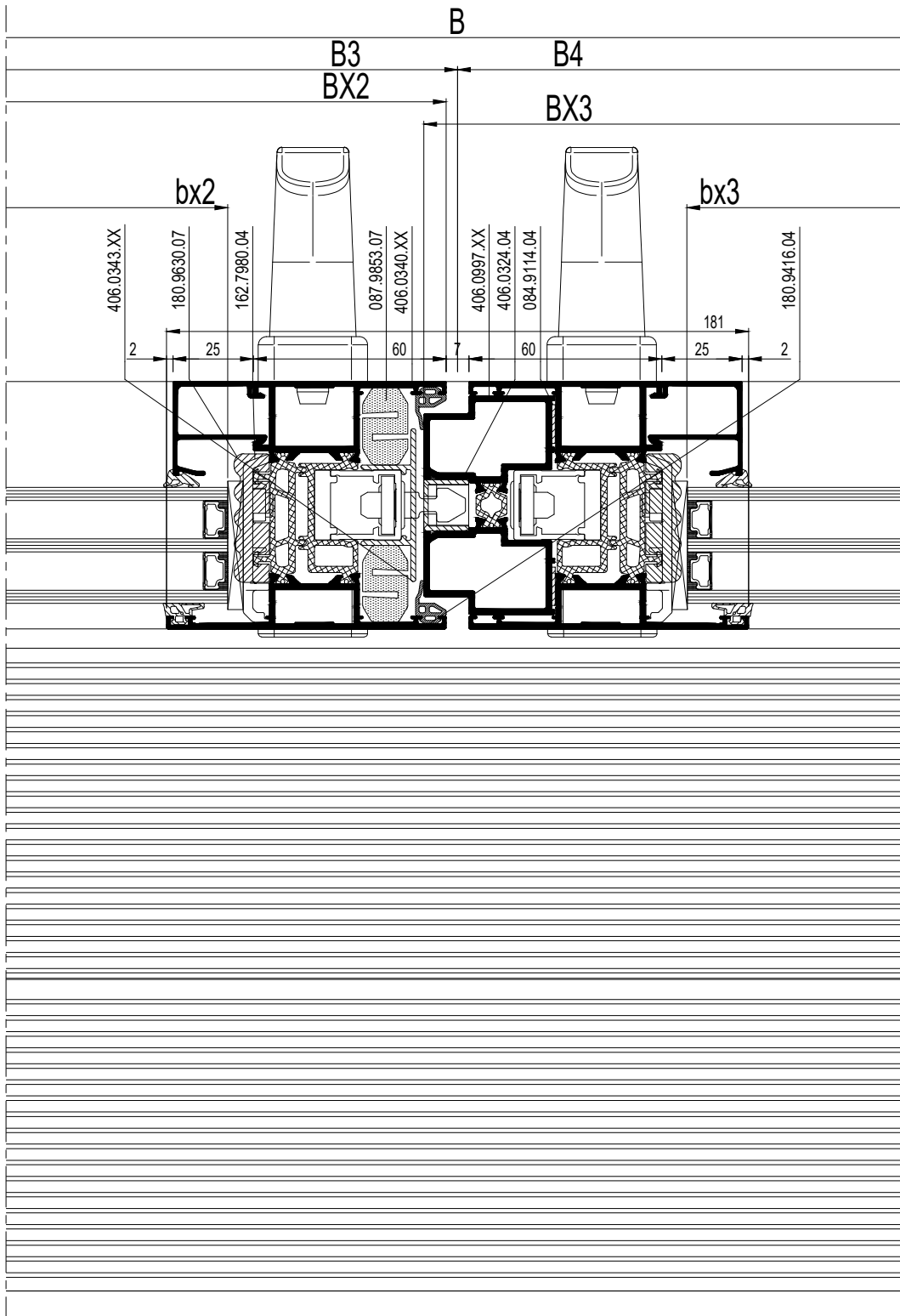

\* KNIP IN STUKKEN  
 \* COUPE EN MORCEAUX  
 \* CUT IN PIECES  
 \* IN STUCKE SCHNEIDEN

schaal - échelle  
 scale - Maßstab  
 1/2

			#	$\leftarrow L_m \rightarrow$				#	$\leftarrow L_m \rightarrow$
406.0305.XXPU			1	B - 66	406.0997.XX			1	H - 192
406.0303.XX			1	B - 66	0M0.1505.00			4	34G.F
406.0345.XX			2	H					
406.0346.XX			2	H					
406.0319.04			1	B1 - 73.5					
			1	B1 + B2 - 73.5					
			1	B5 + B6 - 73.5					
			1	B6 - 73.5					
406.0320.04			8	B - 66					
011.4633.--			1	B1+B2+B3-9.5					
			1	B4+B5+B6-89.5					
			1	B1 + B2 + 10.5					
			1	B5 + B6 + 10.5					
406.0326.04			2	H - 120					
406.0324.04			1	H - 188 *					
406.0363.XX			1	B2 + B3 + B4 + B5 - 87.5					
406.0369.XX			1	B3 + B4 - 95.5					
406.0340.XX			4	H - 106					
			2	B1 + 3.5 (-20)					
			2	(-20)B2+87(-20)					
			2	B3 + 40 (-20)					
			2	B4 + 40 (-20)					
			2	(-20)B5+87(-20)					
			2	B6 + 3.5 (-20)					
406.0343.04			1	H - 176					
030.3613.XX			12	H - 276					
			2	B1 -116.5					
			2	B2 - 33					
			2	B3 - 80					
			2	B4 - 80					
			2	B5 - 33					
			2	B6 - 116.5					
406.0335.XX			8	H - 146					
406.0341.04			8	H - 106					
406.0342.XX			8	H - 154					

		#			#
052.5371.--		24	087.9853.07		2 x (H - 160)
168.8105.00		24	180.9630.07		2B + 12H
168.5012.--		24	Lock set		4
168.8106.00		24	Wheels set		4
050.5091.--		48	162.7930.--		min. 1
160.8725.--		16	162.7940.--		1
160.8750.--		24	162.8036.04		4
052.5300.--		8 x (H / 300)	052.5309.--		8
162.7980.04		18	162.9060.SY		8
162.7990.04		14	162.9061.04		8
169.8748.04		28	162.8081.04		4
162.8170.04		14	162.8062.04		4
050.5081.--		8	162.8063.04		4
052.5305.--		10	162.9335.04		2
162.9355.04		36	180.9160.04		B
162.8172.04		2			(B1+B2)
080.9124.SY		2B + 12H			(B5+B6)
080.9381.04		12H	180.9412.04		(B3+B4)
180.9114.SY		2B + 12H			(B2+B3+B4+B5)
162.8084.04		4			16H
084.9440.07		B1 - 119.5	180.9414.04		2B
		B1 - 254.5 *	180.9416.04		2B + 6H
		B6 - 119.5	180.9493.04		3
		B6 - 254.5 *	062.7715.XX		34G.F
		4 x (H - 159)	069.6830.04		34G.F
		2 x (H - 185)	162.9351.SY		1
		2 x (H - 255) *	162.9361.SY		1
084.9439.07		B2 + 18.5	180.8120.04		1
		B3 - 28.5	050.5074.--		34G.F
		B4 - 28.5	084.9114.04		2H
		B5 + 18.5			

schaal - échelle  
 scale - Maßstab  
 1/2

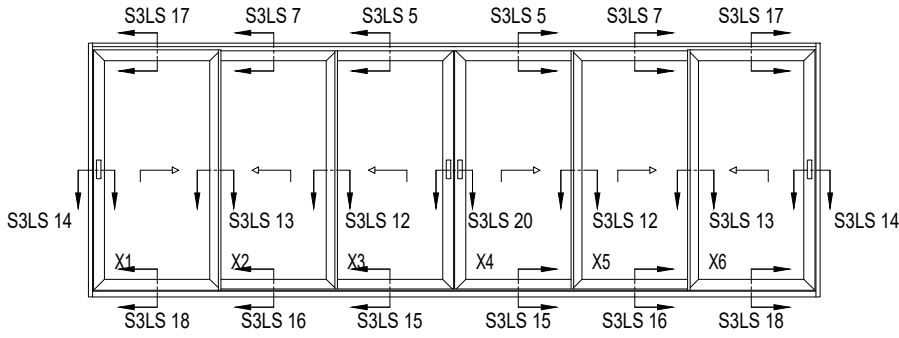

## S3LS 20

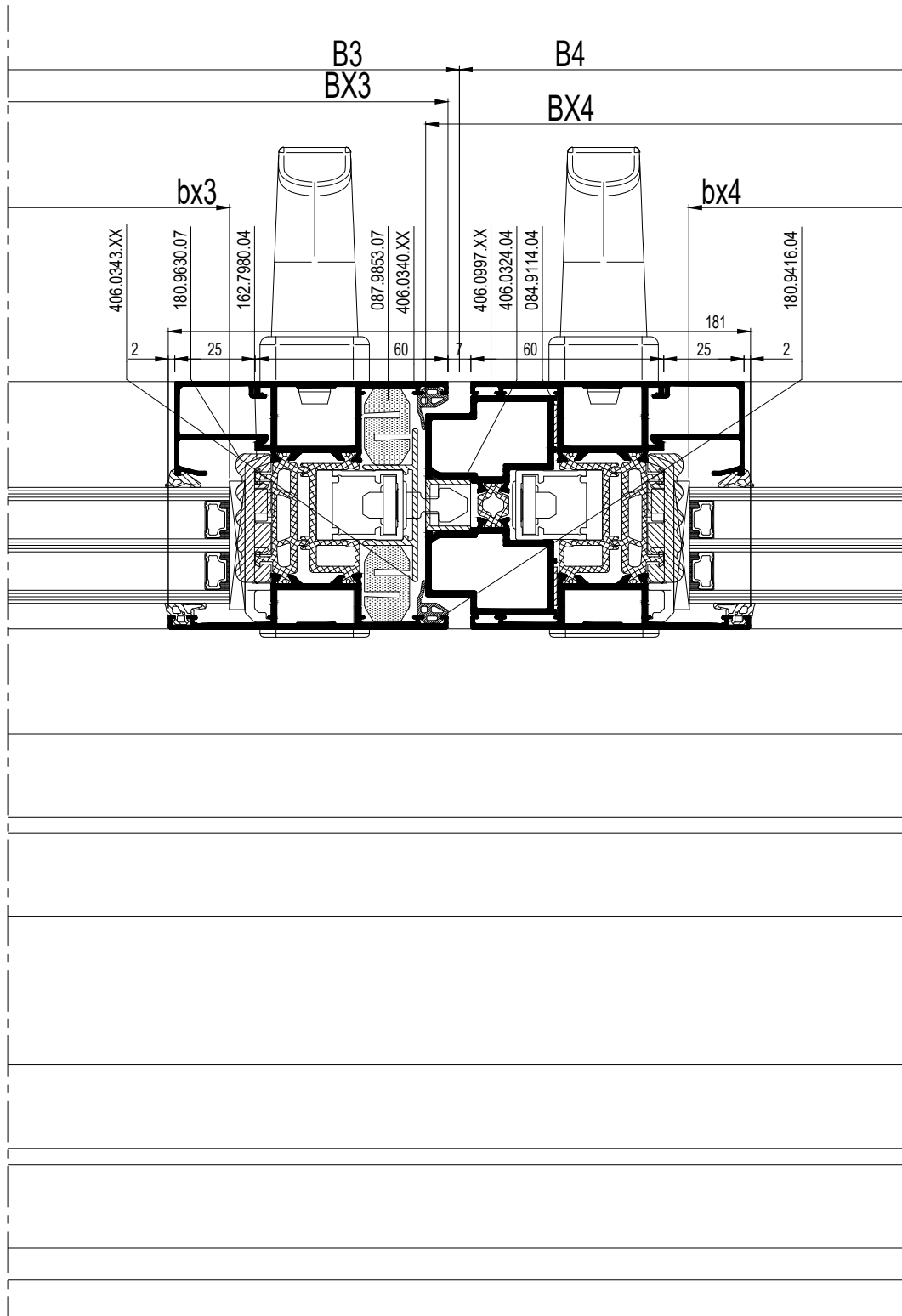

BX1 = B1+3.5
BX2 = B2+87
BX3 = B3+40
BX4 = B4+54
BX5 = B5+87
BX6 = B6+3.5
HX = H-106
bx1 = BX1-136
bx2 = BX2-136
bx3 = BX3-136
bx4 = BX4-150
bx5 = BX5-136
bx6 = BX6-136
hx = HX-136

schaal - échelle  
 scale - Maßstab  
 1/2

			#	$\leftarrow L_m$
406.0305.XXPU			1	B - 66
406.0303.XX			1	B - 66
406.0345.XX			2	H
406.0346.XX			2	H
406.0319.04			1	B1 - 73.5
			1	B1 + B2 - 73.5
			1	B3 + B4 - 81
			1	B2+B3+B4+B5-81
			1	B5 + B6 - 73.5
			1	B6 - 73.5
406.0320.04			8	B - 66
011.4633.--			1	B1+B2+B3-9.5
			1	B4+B5+B6-89.5
			1	B - 66
			1	B - 94
406.0326.04			2	H - 120
406.0324.04			2	H - 120 *
			1	H - 188 *
406.0340.XX			4	H - 106
			2	B1 + 3.5 (-20)
			2	(-20)B2+87(-20)
			2	B3 + 40 (-20)
			2	B4 + 40 (-20)
			2	(-20)B5+87(-20)
406.0343.04			3	H - 176
			12	H - 276
			2	B1 -116.5
			2	B2 - 33
			2	B3 - 80
			2	B4 - 80
			2	B5 - 33
	2	B6 - 116.5		
406.0335.XX			8	H - 146
406.0341.04			8	H - 106
406.0342.XX			8	H - 154
406.0997.XX			1	H - 192

		#			#	
052.5371.--		24	087.9853.07		6 x (H - 160)	
168.8105.00		24	180.9630.07		2B + 12H	
168.5012.--		24	Lock set		6	
168.8106.00		24	Wheels set		6	
050.5091.--		48	162.7930.--		min. 3	
160.8725.--		16	162.7940.--		1	
160.8750.--		24	162.8036.04		4	
052.5300.--		8 x (H / 300)	052.5309.--		8	
162.7980.04		27	162.9060.SY		8	
162.7990.04		15	162.9061.04		8	
169.8748.04		24	162.8081.04		4	
162.9355.04		36	162.8062.04		4	
080.9124.SY		2B + 12H	162.8063.04		4	
080.9381.04		12H	162.9335.04		2	
180.9114.SY		2B + 12H	180.9160.04		3B	
162.8084.04		4	180.9412.04		16H	
084.9440.07		6 x (H -159)	180.9414.04		2B	
084.9439.07		B1 - 65	180.9416.04		2B + 6H	
		B2 + 18.5	180.9493.04		3	
		B3 - 28.5	062.7715.XX			34G.F
		B4 - 28.5	069.6830.04			34G.F
		B5 + 18.5	180.8120.04			1
		B6 - 65	050.5074.--			34G.F
			084.9114.04		2H	

0M0.1505.00			6		34G.F
-------------	--	--	---	--	-------

MONORAIL BG VERBORGEN ONTWERING  
 MONORAIL VE DRAINAGE CACHE

MONORAIL OG HIDDEN DRAINAGE  
 MONORAIL AG VERSTECKTE ENTWÄSSERUNG

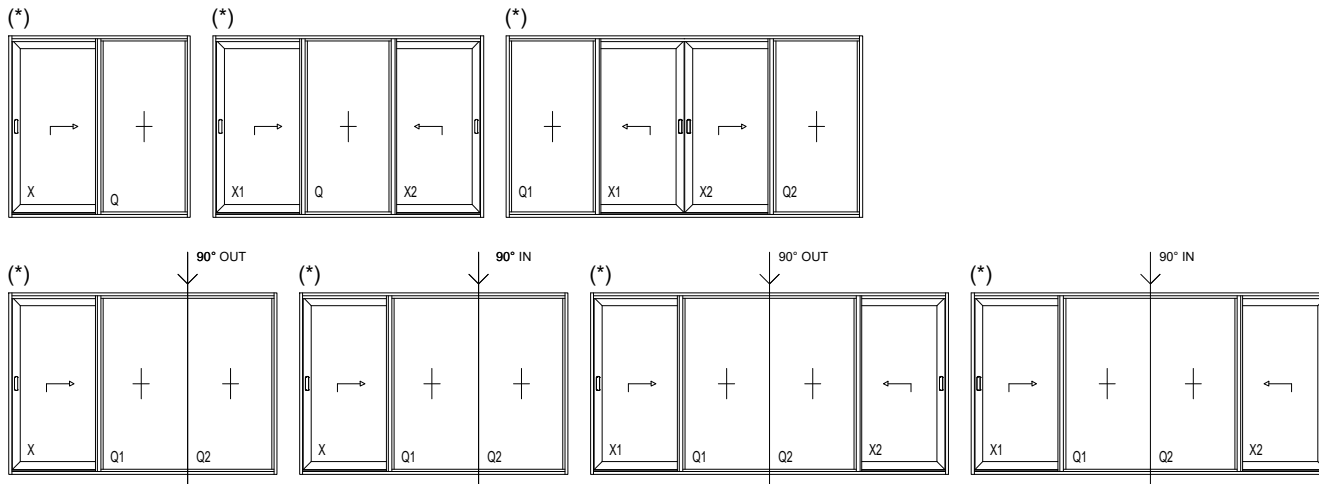

X : PRIMAIRE VLEUGEL  
 Q : VASTE VLEUGEL  
 O : SECONDAIRE VLEUGEL  
 V : HOEKOPLOSSING

X : OUVRANT PRIMAIRE  
 Q : OUVRANT FIXE  
 O : OUVRANT SECONDAIRE  
 V : SOLUTION ANGULAIRE

X : PRIMARY SLIDING VENT  
 Q : FIXED VENT  
 O : SECONDARY SLIDING VENT  
 V : CORNER SOLUTION

X : GANGFLUEGEL  
 Q : FENSTER FLUEGEL  
 O : STANDFLUEGEL  
 V : ECKLÖSUNG

(\*)  
 SMALLE CHICANE MOGELIJK (406.0330.XX)  
 CHICANE ETROITE POSSIBLE (406.0330.XX)  
 SLIM CHICANE POSSIBLE (406.0330.XX)  
 SCHMALE SCHIKANE MÖGLICH (406.0330.XX)

### STANDARD MONORAIL OG

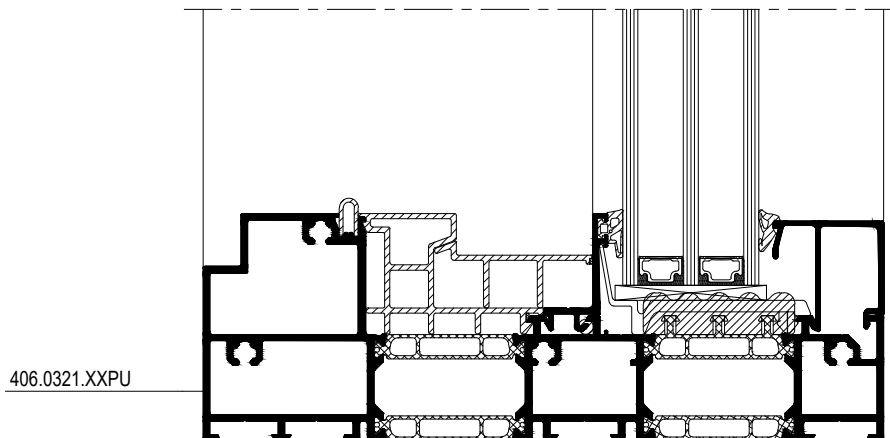



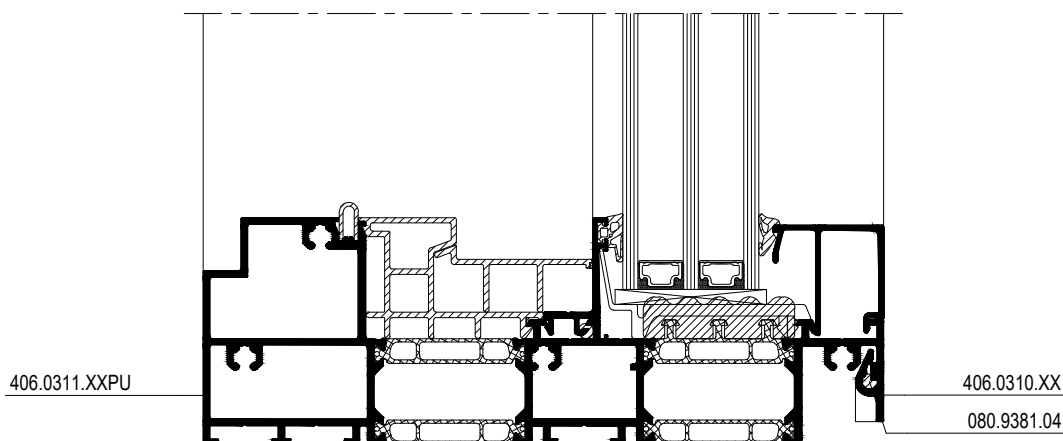



### MONORAIL OG HIDDEN DRAINAGE











schaal - échelle  
 scale - Maßstab  
 1/2



## STANDARD MONORAIL OG

			#	
406.0321.XXPU			1	B-66



## MONORAIL OG HIDDEN DRAINAGE

			#	
406.0311.XXPU			1	B-66
+ 406.0310.XX			1	B-66

		#
080.9381.04		B



**STANDARD MONORAIL OG**

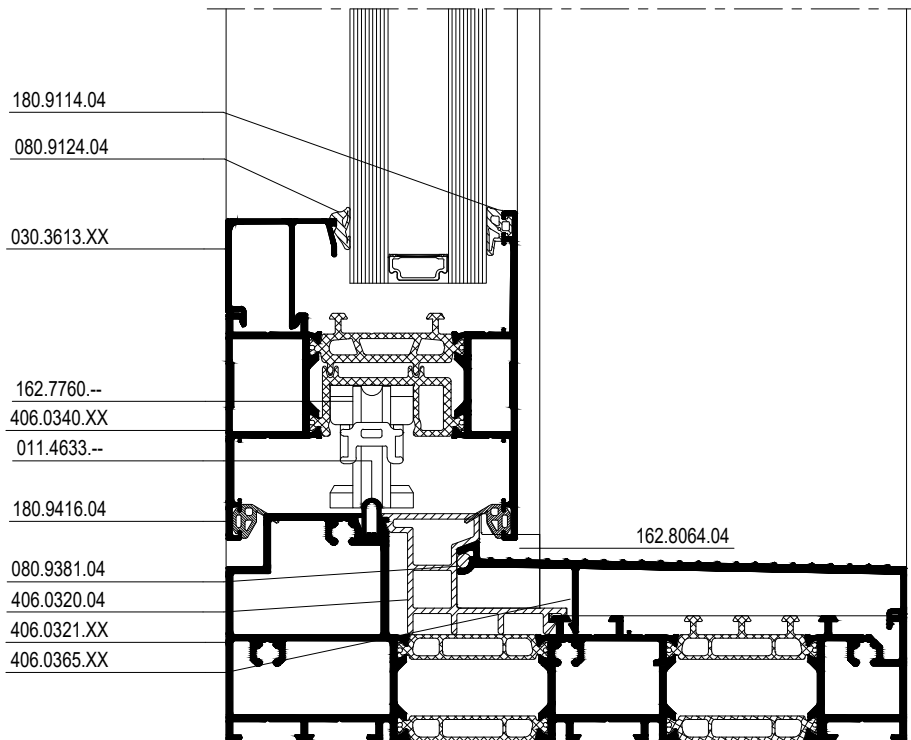

**MONORAIL OG REVERSED VENT**

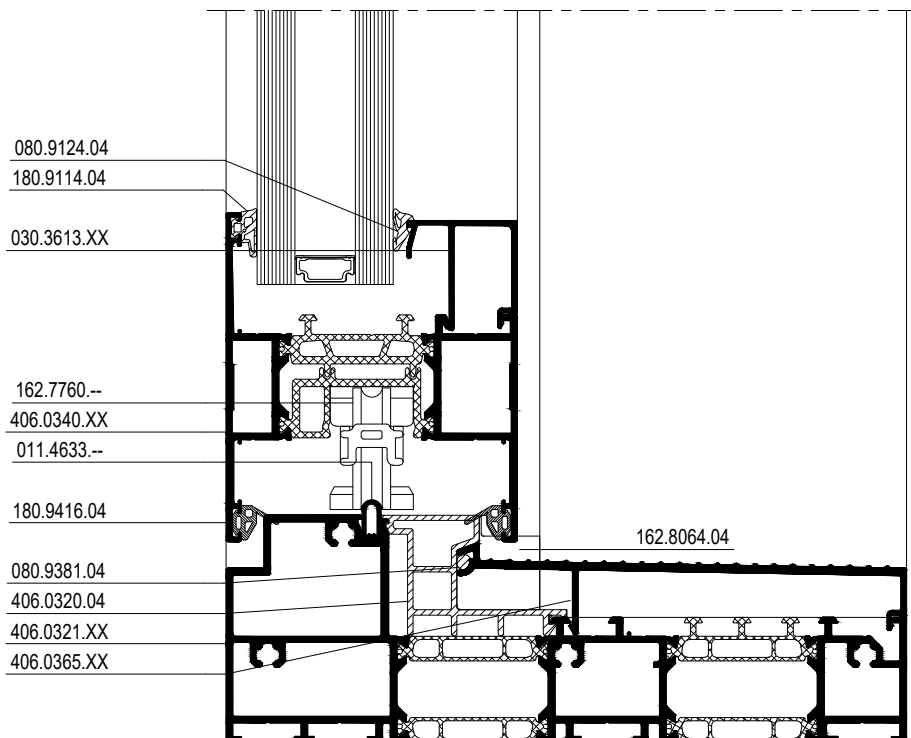

\* CONFIGURATIE NIET MOGELIJK IN REYNAPRO  
 \* CONFIGURATION IMPOSSIBLE DANS REYNAPRO  
 \* CONFIGURATION NOT POSSIBLE IN REYNAPRO  
 \* KONFIGURATION NICHT MÖGLICH IN REYNAPRO



schaal - échelle  
 scale - Maßstab  
 1/2



E



**F**

**R**

Reynaers  
Aluminium

**Montagetekeningen**  
**Fabrication et montage**  
**Assembly drawings**  
**Montagezeichnungen**





①

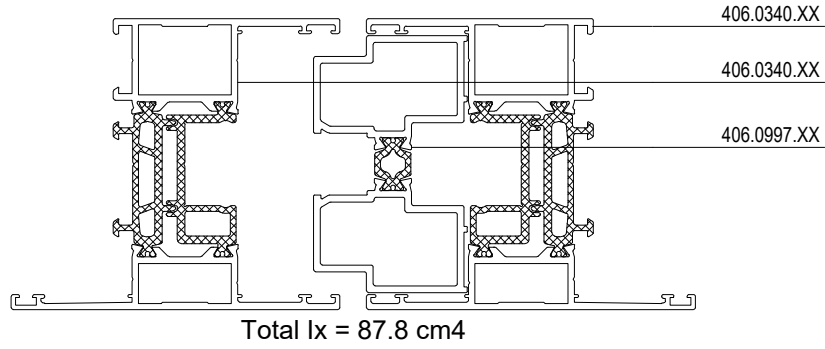

②  
OG

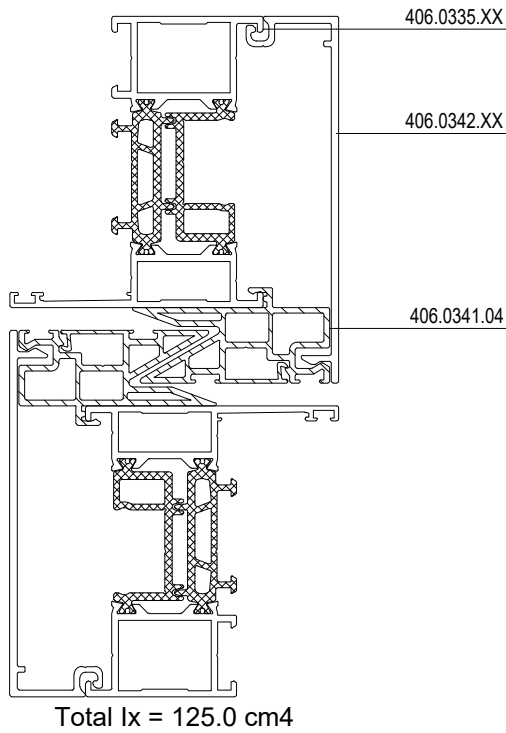

②  
IG

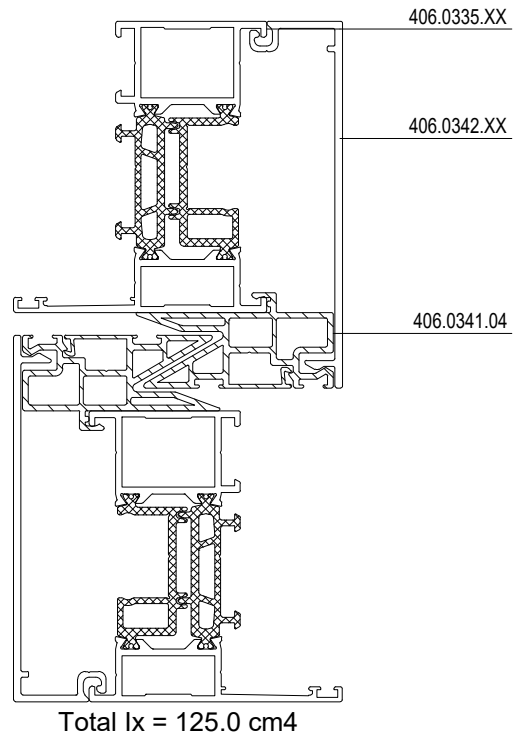

③

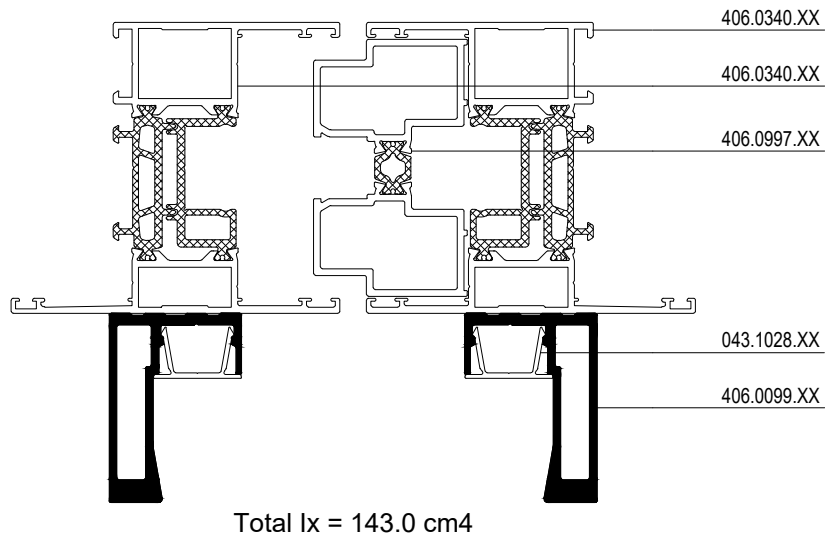

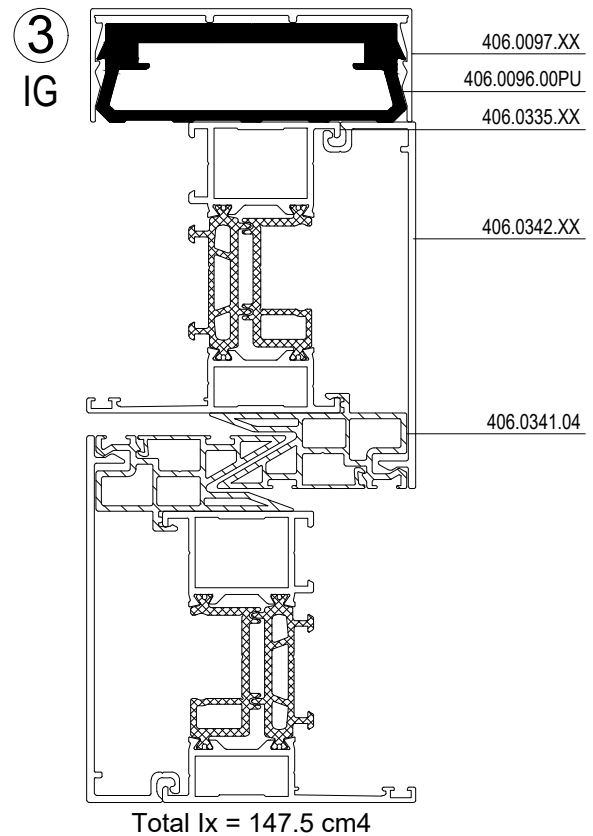
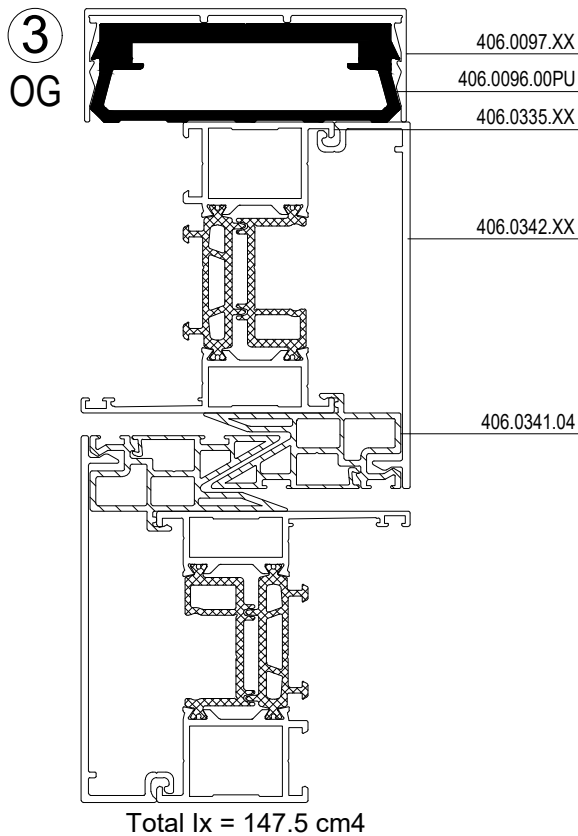
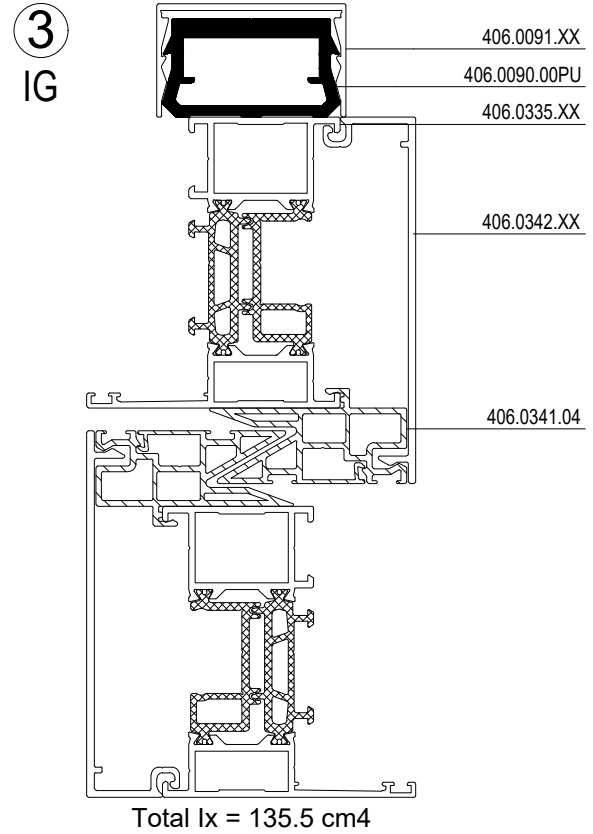
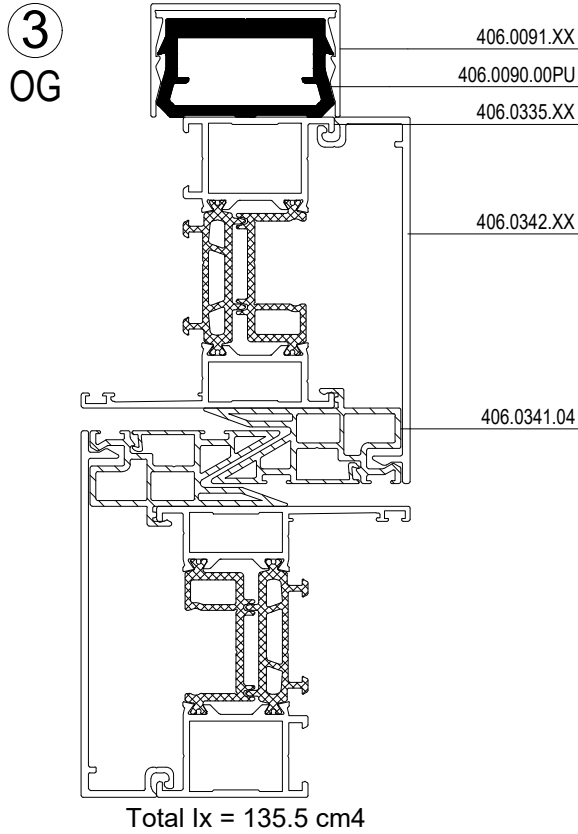

4

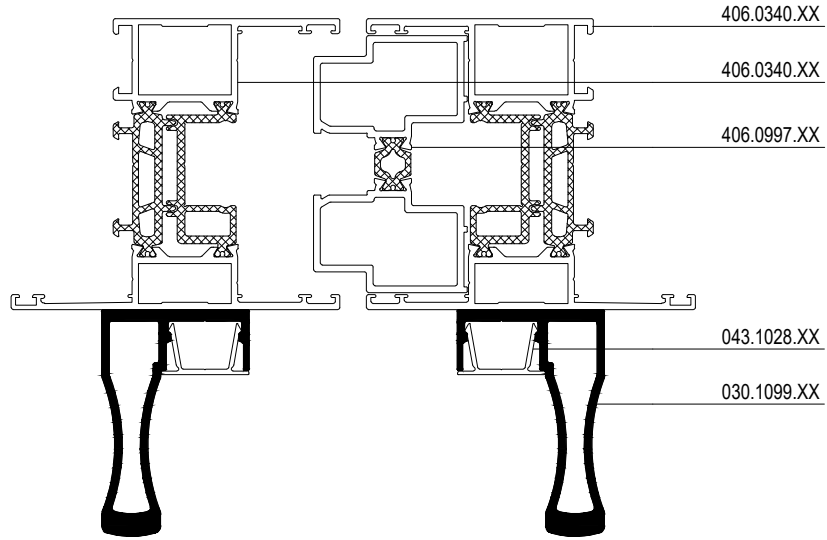

Total Ix = 166.8 cm<sup>4</sup>

④  
OG

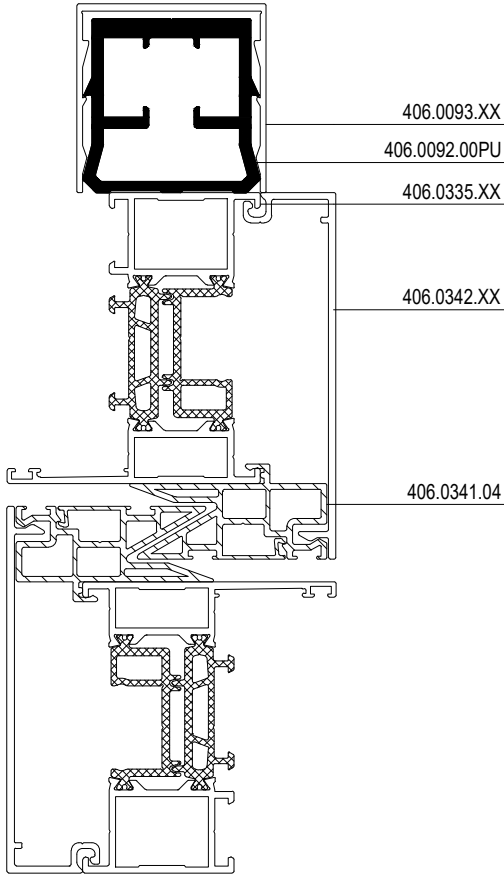

Total lx = 168.5 cm4

④  
IG

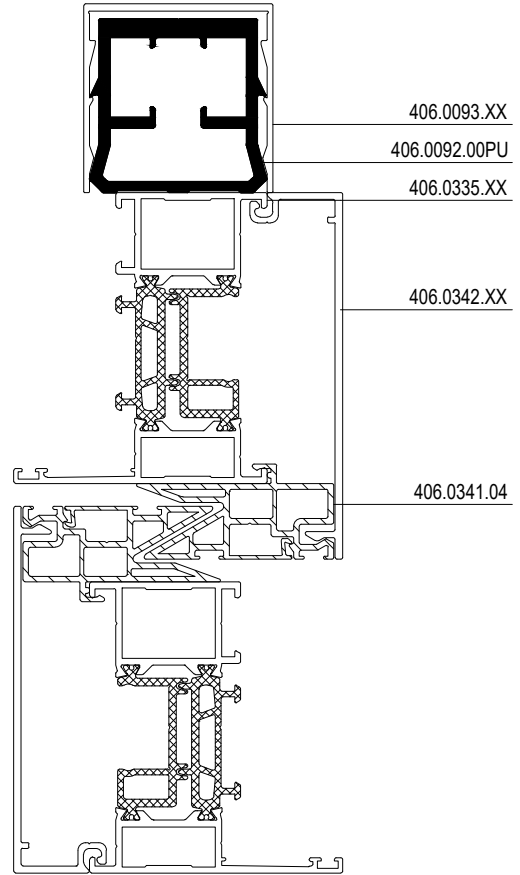

Total lx = 168.5 cm4

④  
OG

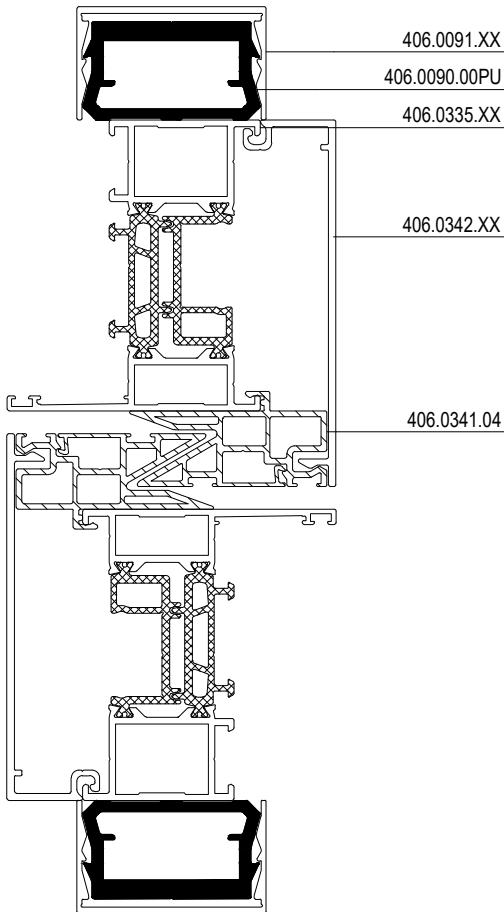

Total lx = 170.4 cm4

④  
IG

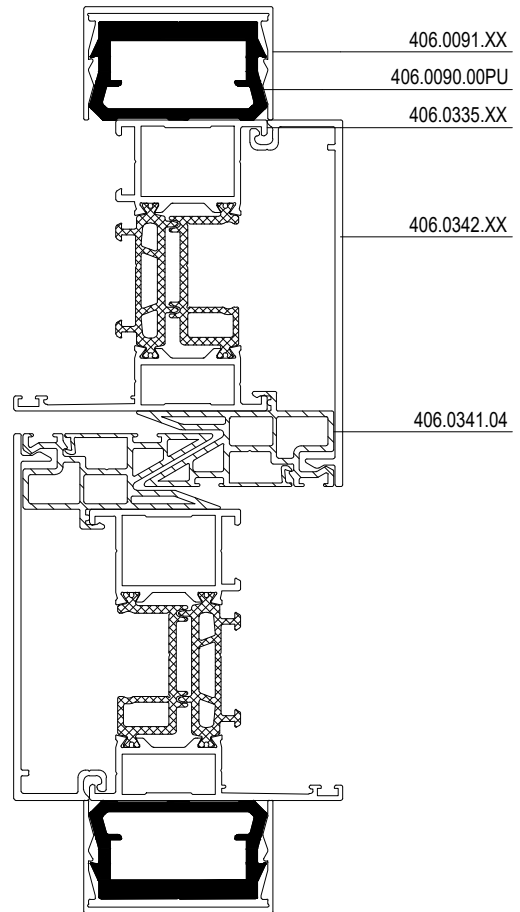

Total lx = 162.3 cm4

schaal - échelle  
 scale - Maßstab  
 1/2

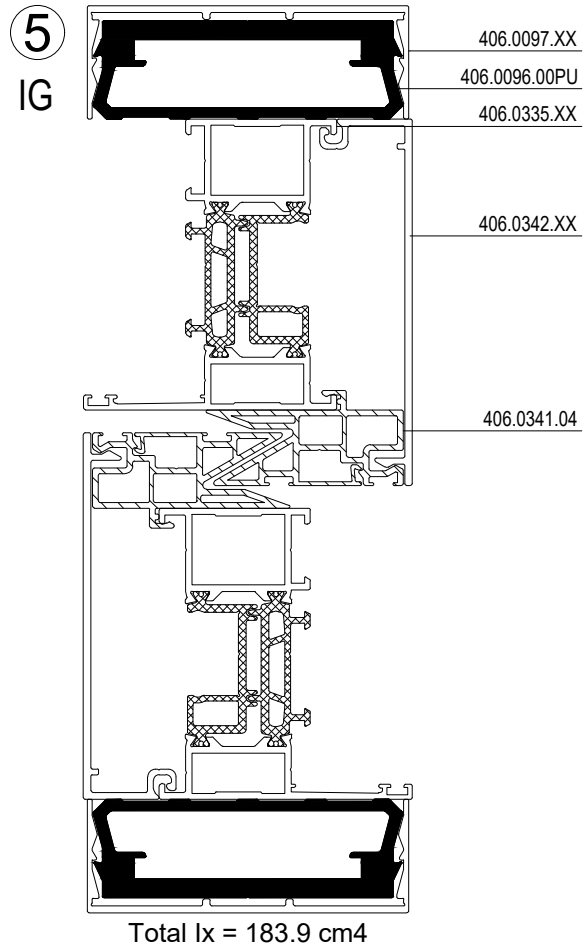
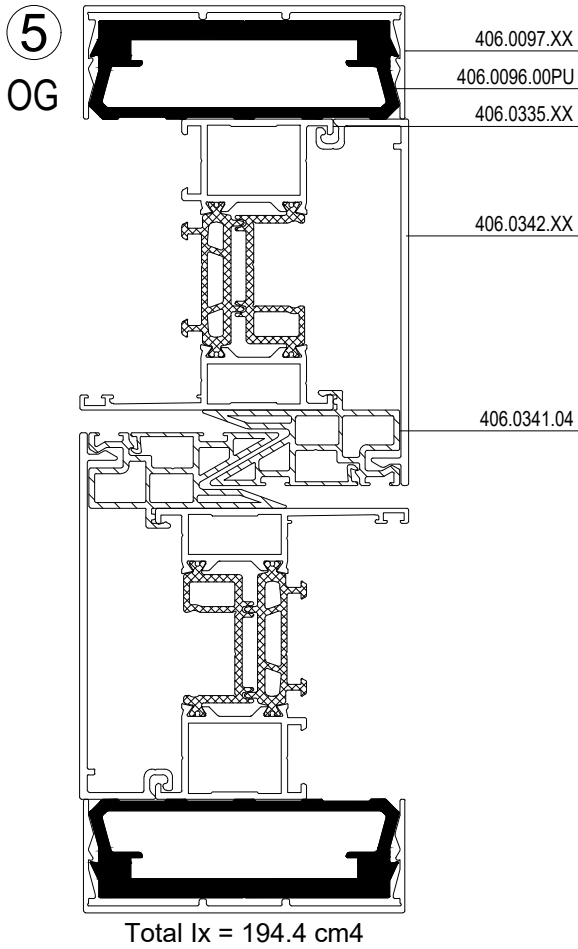

5  
OG

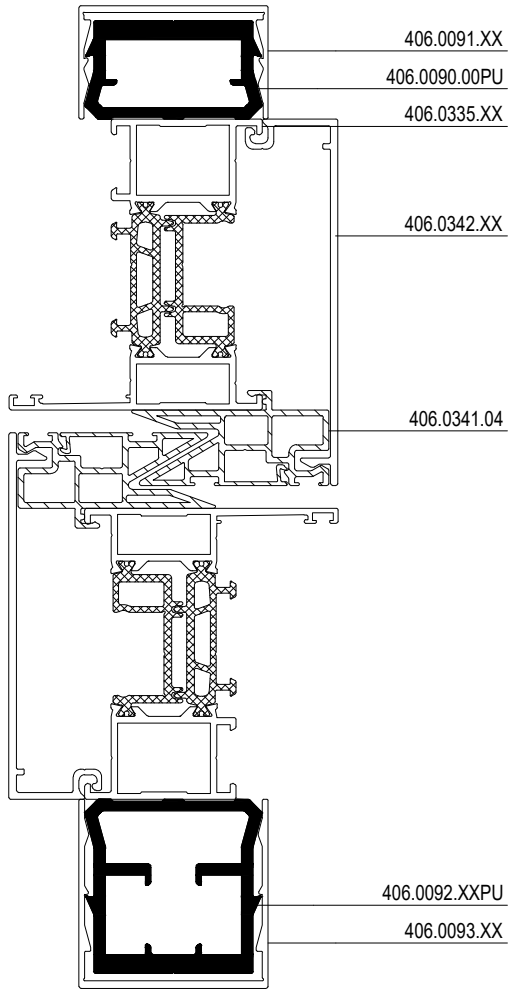

Total lx = 203.4 cm4

5  
IG

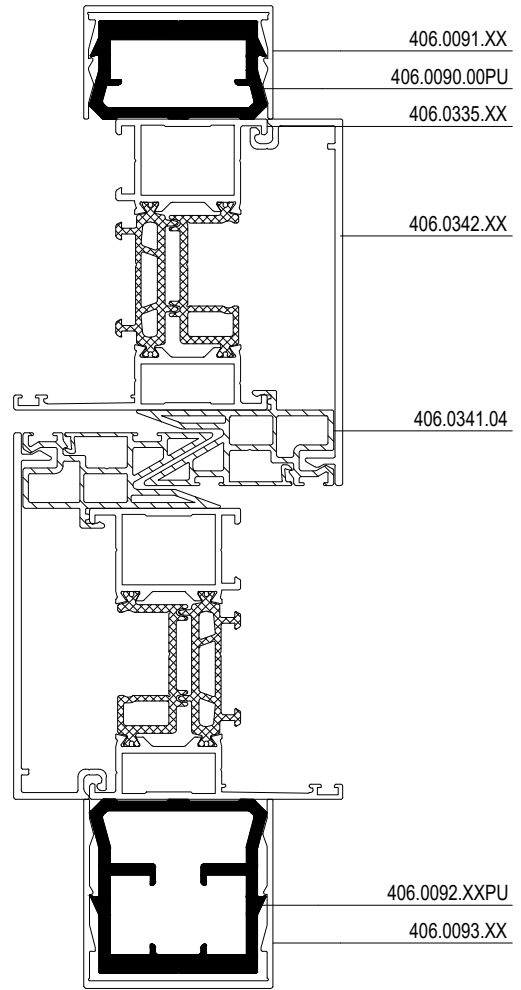

Total lx = 192.0 cm4

F

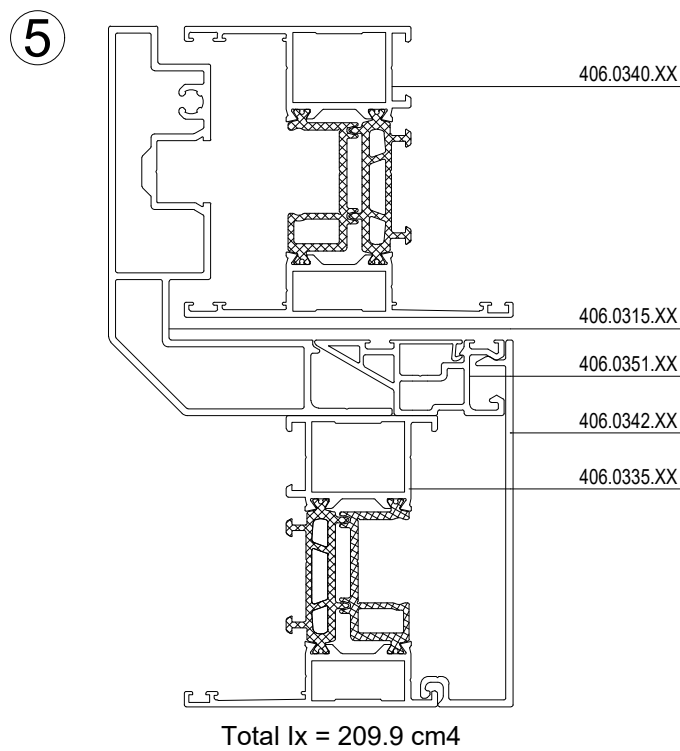
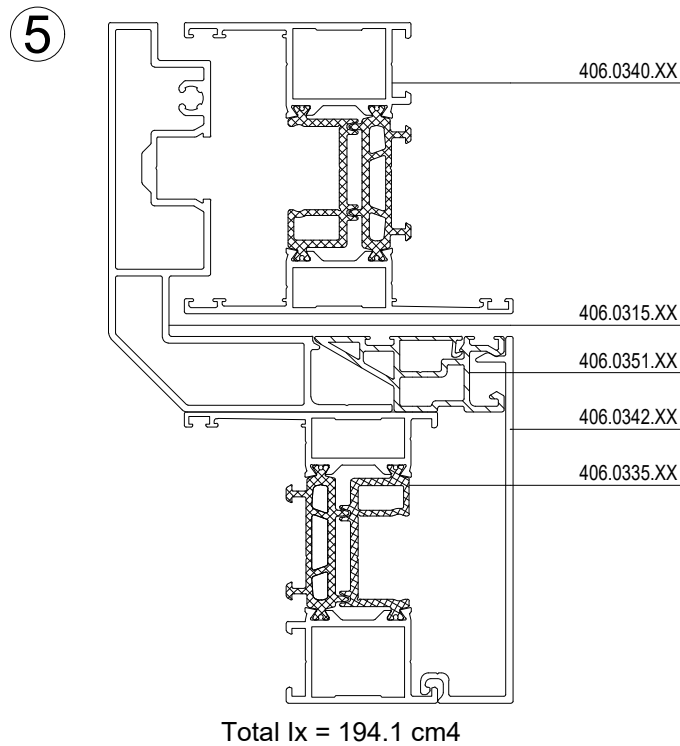

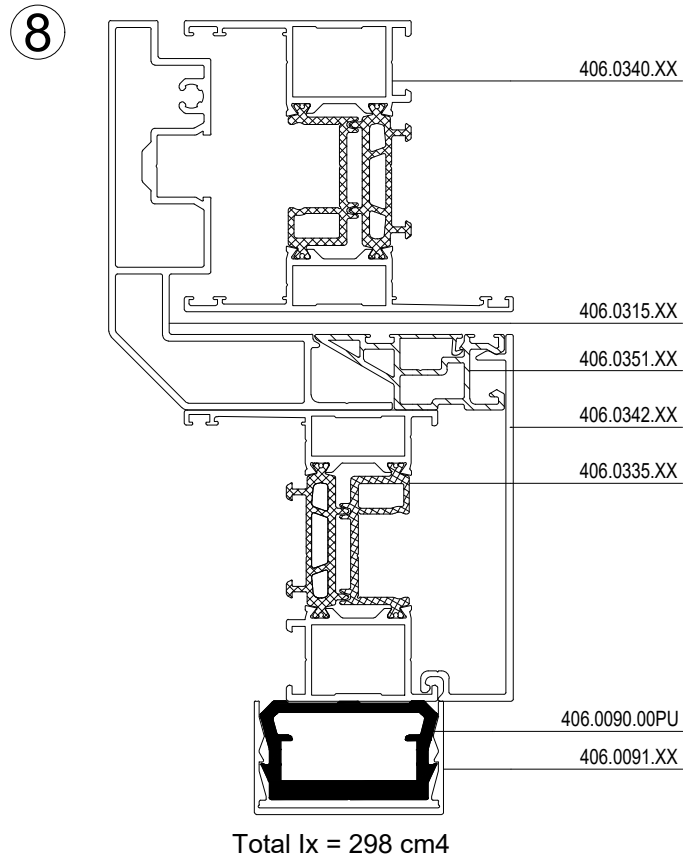

6  
OG

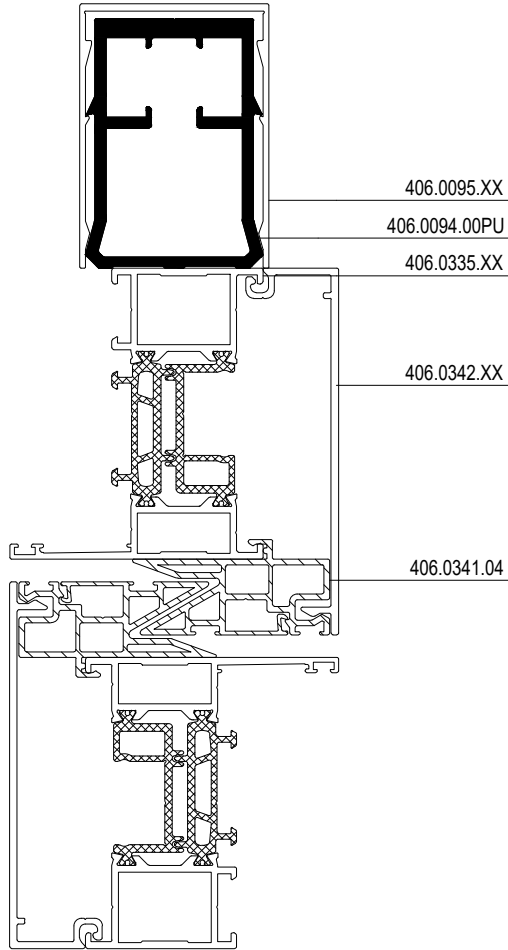

Total Ix = 216.1 cm<sup>4</sup>

6  
IG

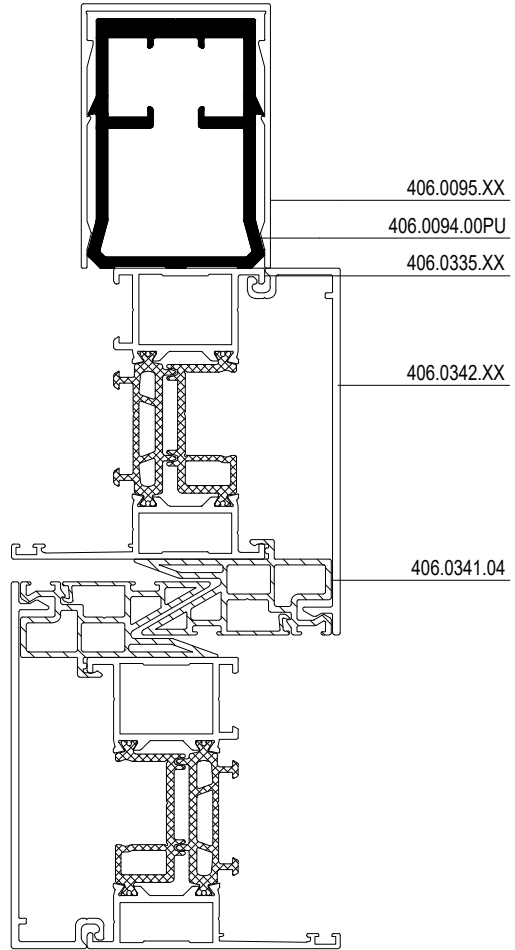

Total Ix = 216.1 cm<sup>4</sup>

⑥  
OG

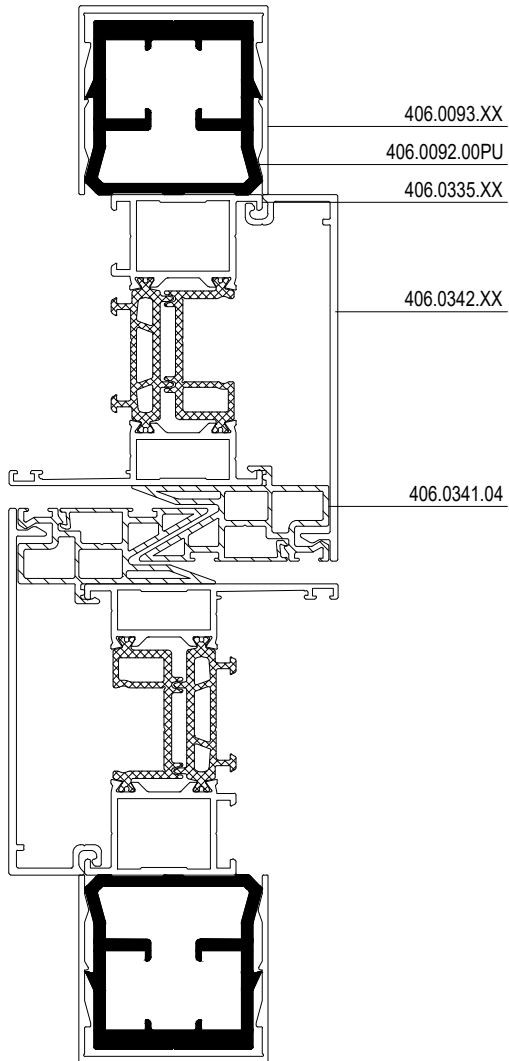

Total Ix = 236.4 cm<sup>4</sup>

⑥  
IG

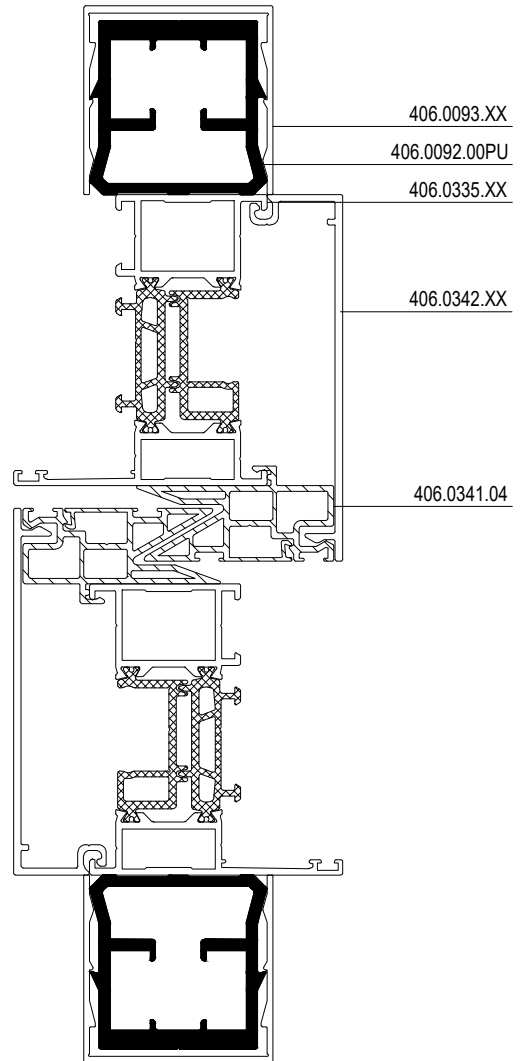

Total Ix = 225.0 cm<sup>4</sup>

F

7  
OG

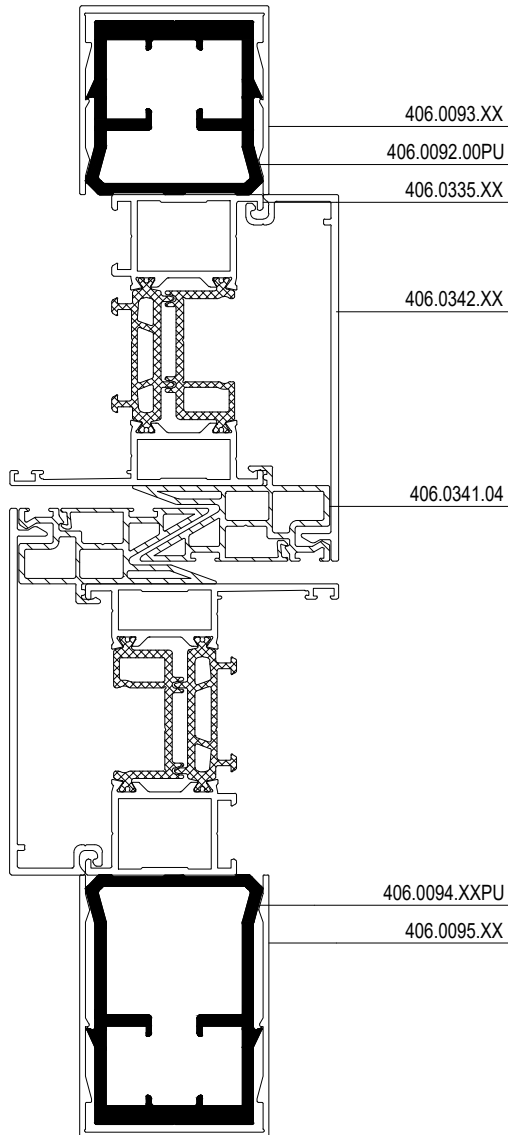

Total Ix = 255.6 cm<sup>4</sup>

7  
IG

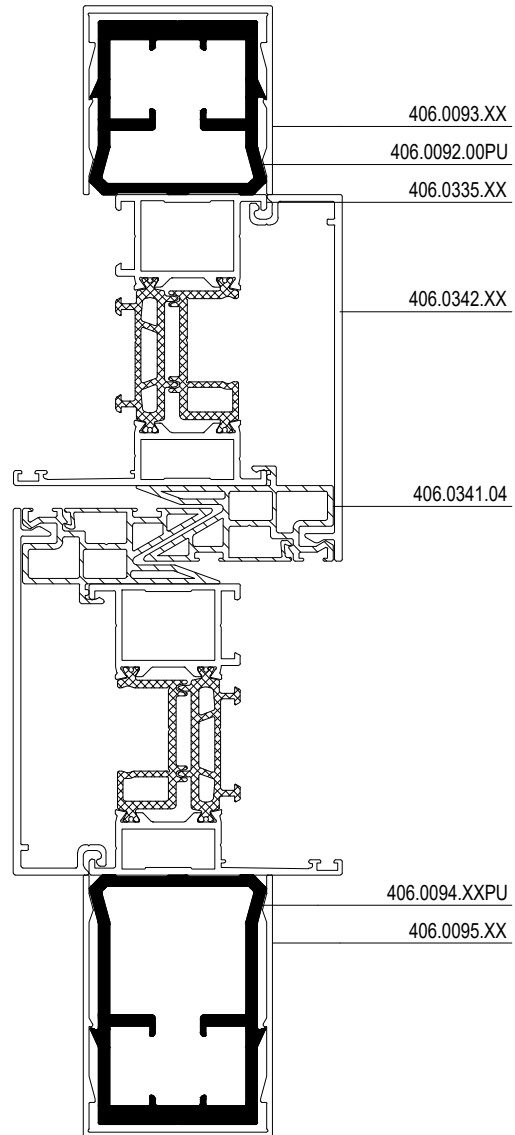

Total Ix = 242.5 cm<sup>4</sup>

8  
OG

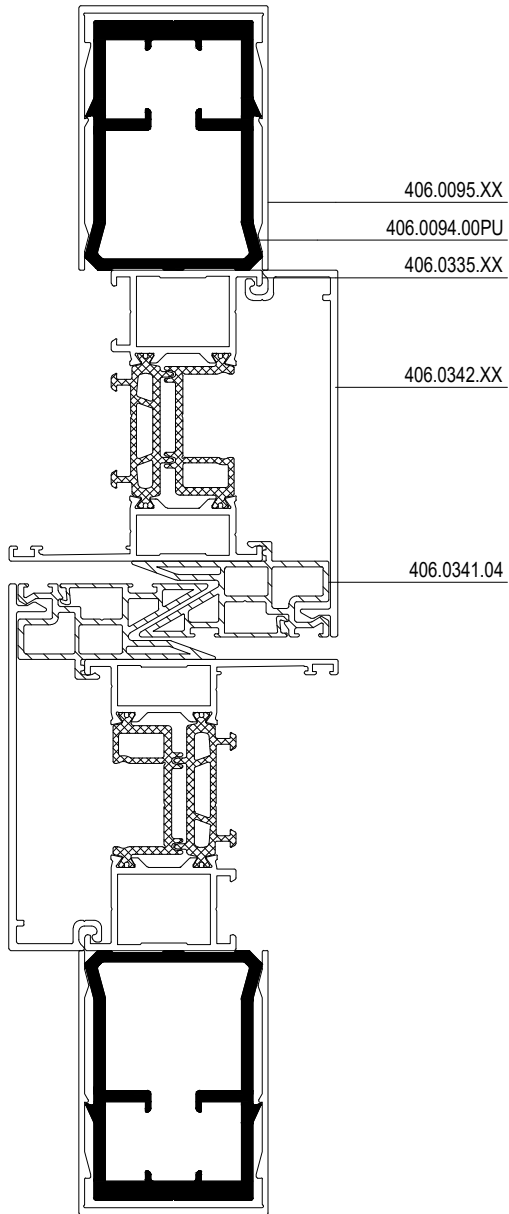

Total Ix = 298.4 cm4

8  
IG

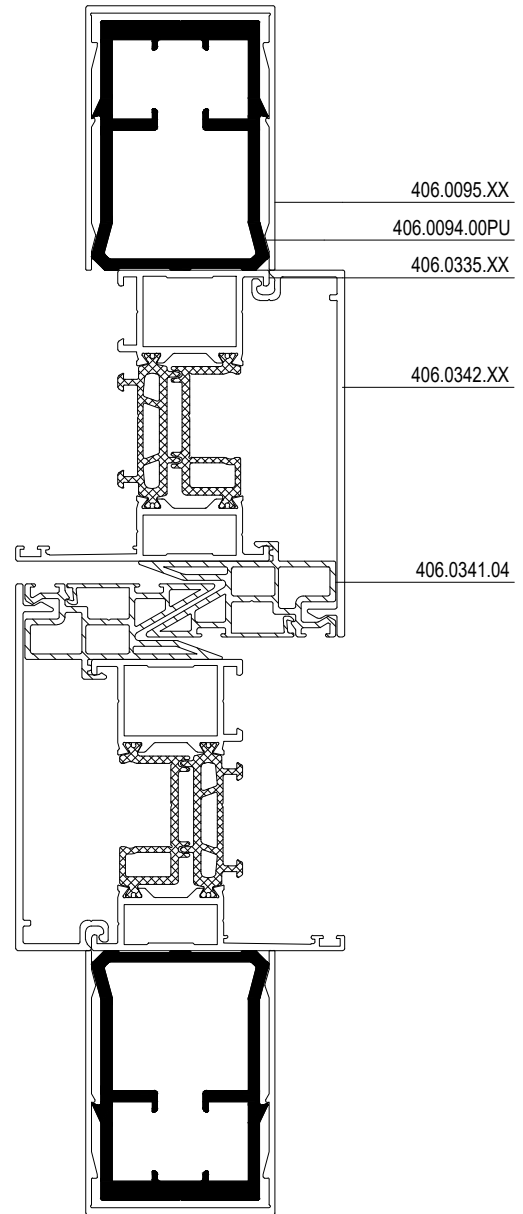

Total Ix = 285.4 cm4

PROFIELCOMBINATIES DIE KUNNEN GEBRUIKT WORDEN TOT DE EERST VOLGENDE GRENSLIJN  
 COMBINAISON DES PROFILES QUI PEUT ETRE UTILISE JUSQU'A LA PROCHAINE FRONTIERE  
 PROFILE COMBINATIONS WHICH CAN BE USED UNTIL FIRST FOLLOWING BOUNDARIE  
 PROFILKOMBINATIONEN DAS KANN BIS VERWENDET WERDEN BIS ZUM NACHSTEN GRENZE

GRENSLIJNEN HOOGTE/BREEDTE VERHOUDING  
 FRONTIERES HAUTEUR/LARGEUR RATIO  
 BOUNDARIES HEIGHT/WIDTH RATIO  
 GRENZEN HOHE/BREITE VERHALTNIS

GRENSLIJNEN MAXIMAAL GLASGEWICHT  
 FRONTIERES POIDS DE VERRE MAXIMUM  
 BOUNDARIES MAXIMUM GLASS WEIGHT  
 GRENZEN MAXIMUM GLASGEWICHT

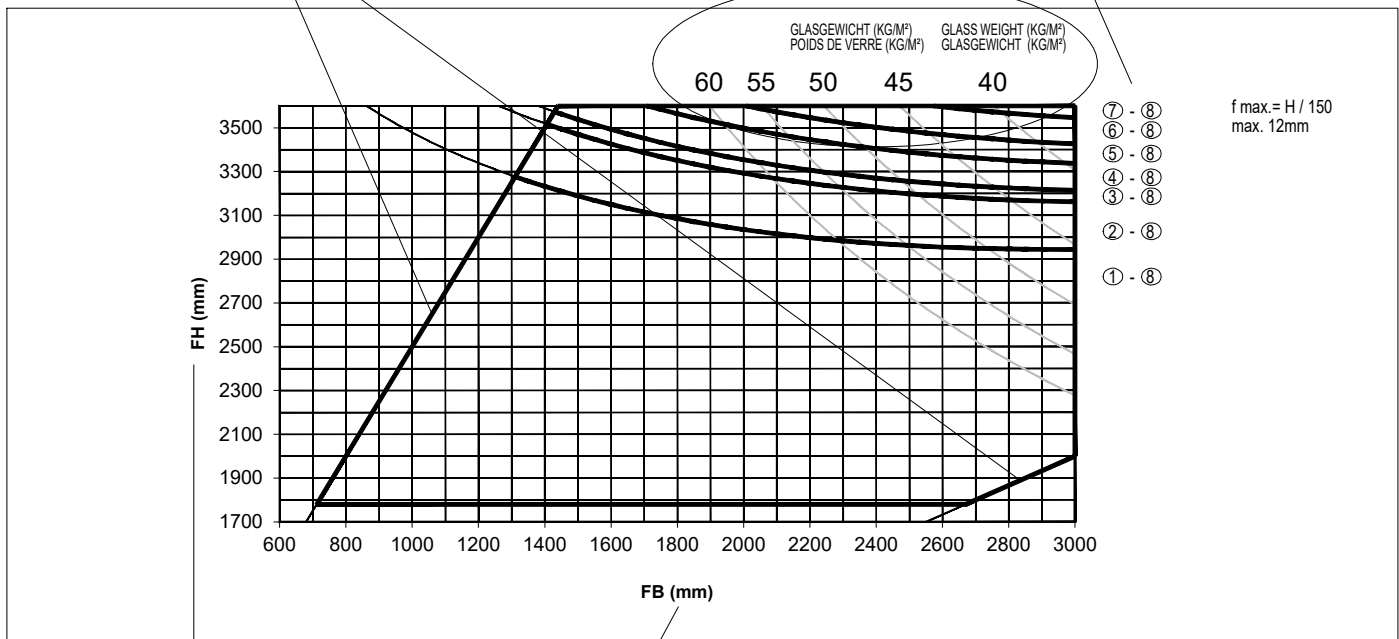

$f_{max} = H / 150$   
 max. 12mm

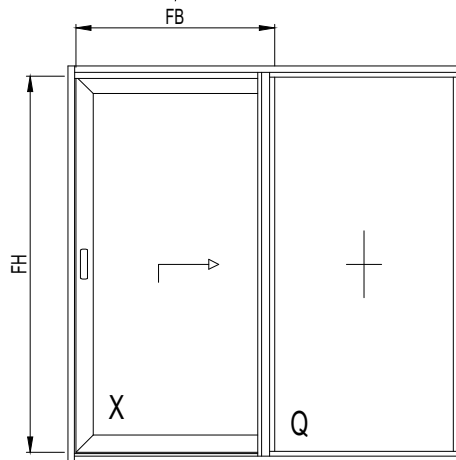

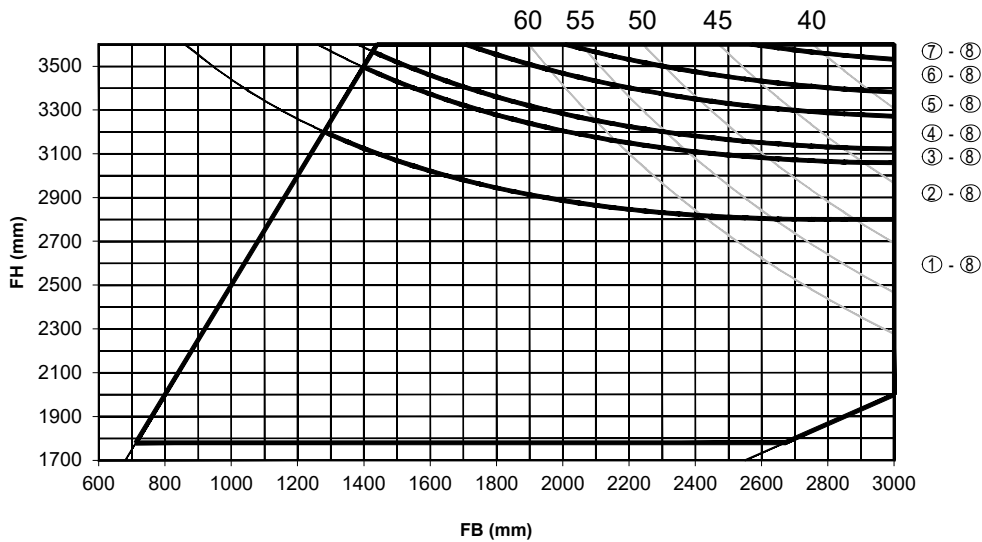
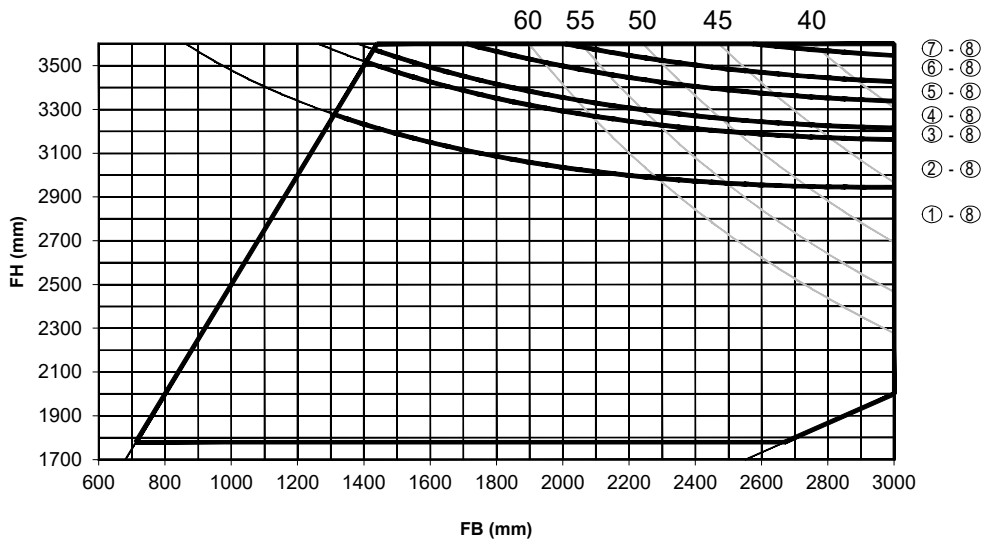
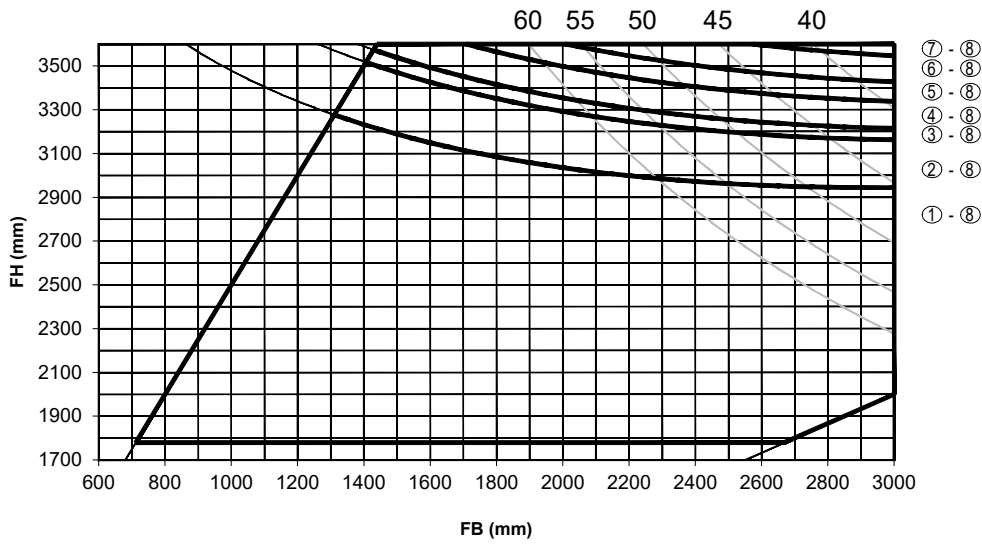

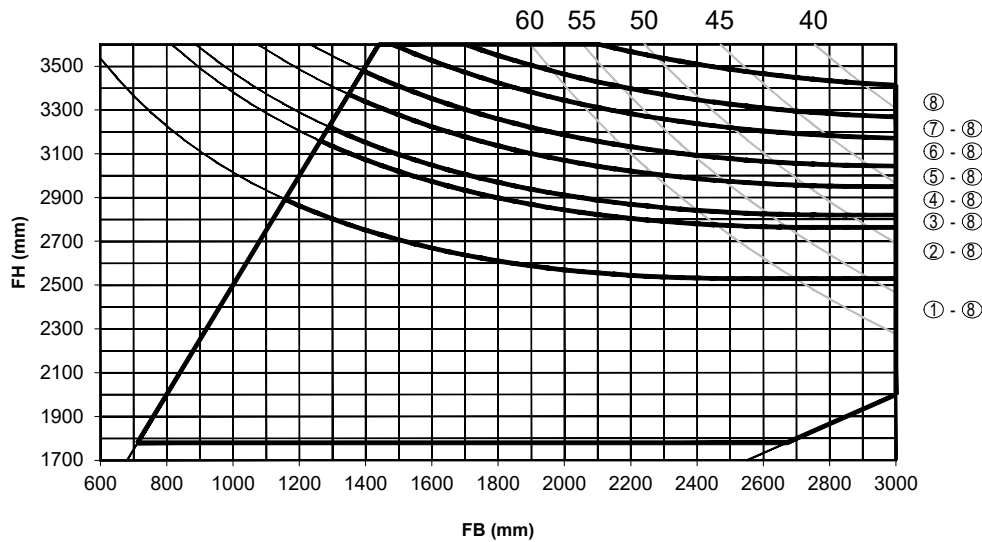
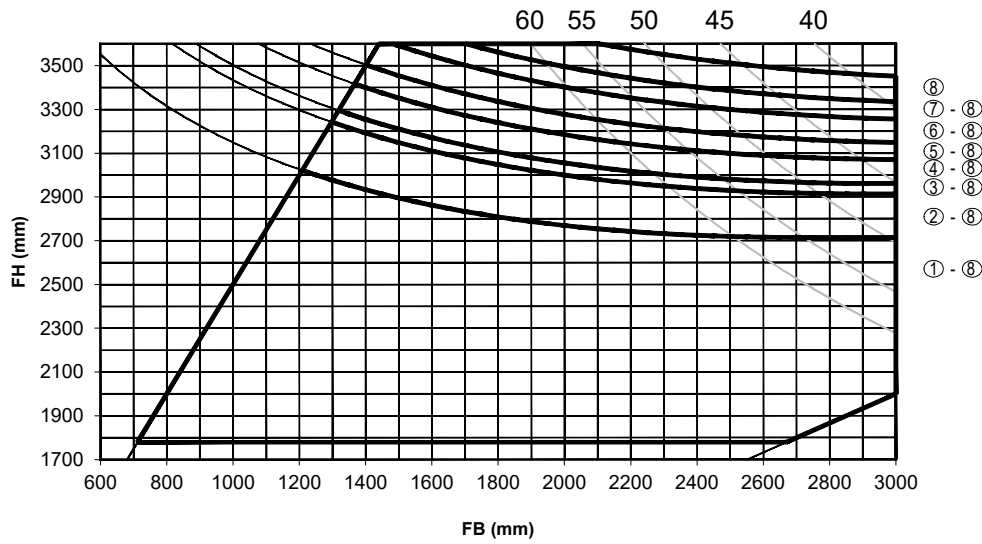
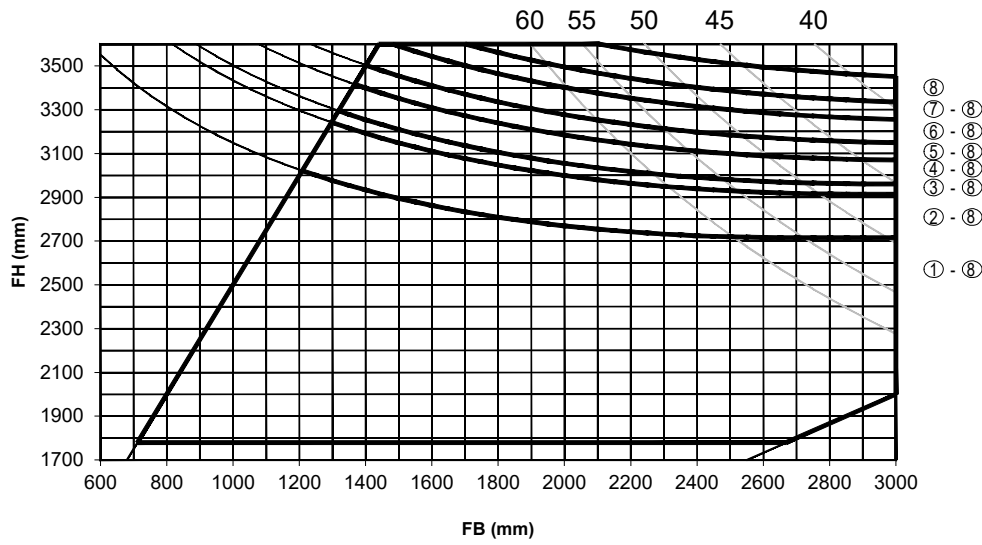

P = 600Pa  
 FG max = 400kg

P = WINDDRUK  
 P = PRESSION DU VENT  
 P = WINDDRUCK  
 P = WIND PRESSURE  
 FG = VLEUGELGEWICHT  
 FG = POIDS DU VANTAIL  
 FG = FLÜGELGEWICHT  
 FG = WEIGHT OF THE VENT  
 f = DOORBUIGING  
 f = FLEXION  
 f = DURCHBIEGUNG  
 f = DEFLECTION

schaal - échelle  
 scale - Maßstab  
 1/2

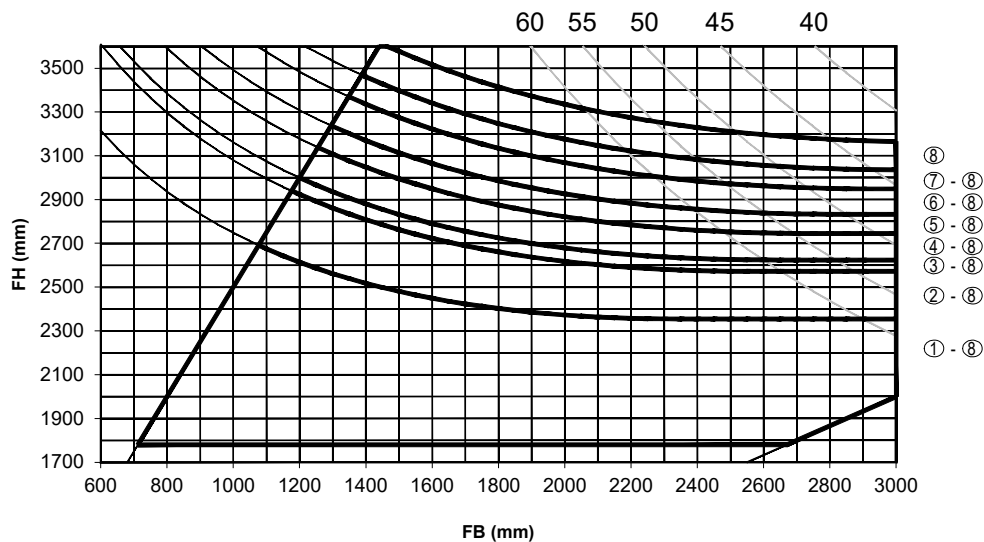
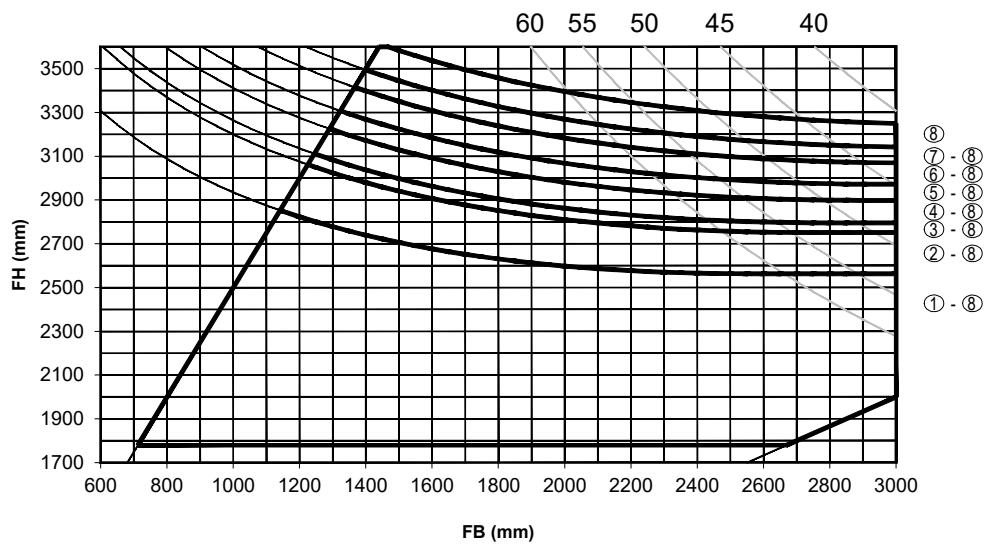
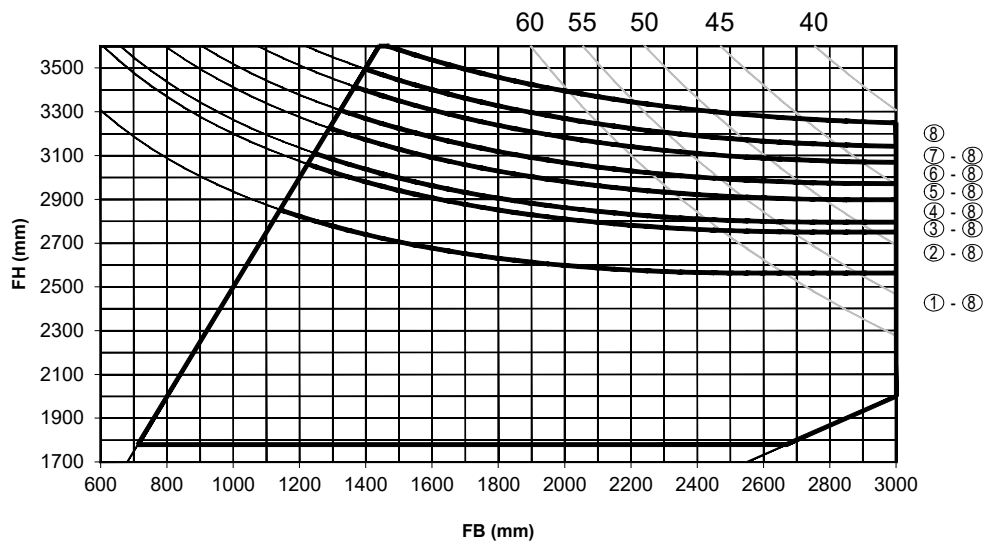

schaal - échelle  
 scale - Maßstab  
 1/2

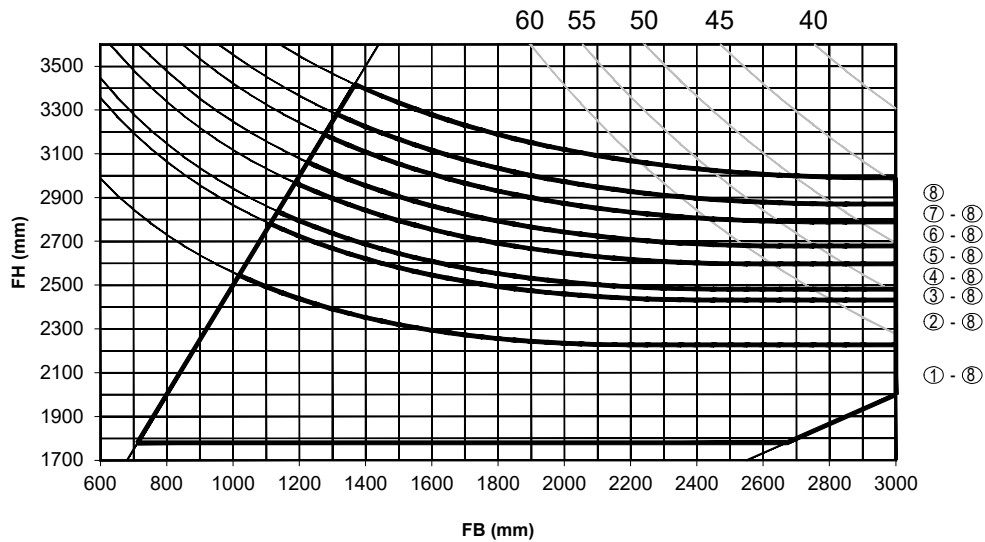
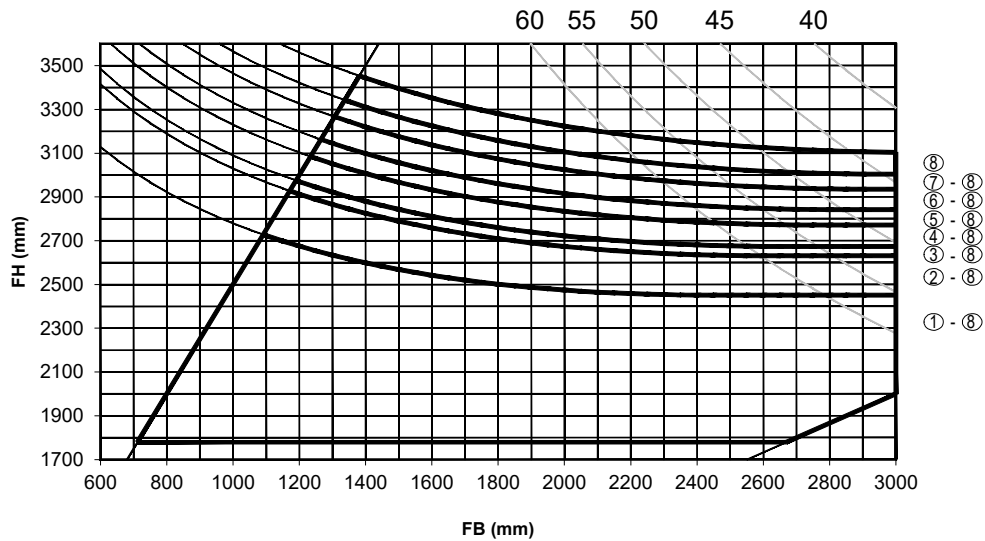
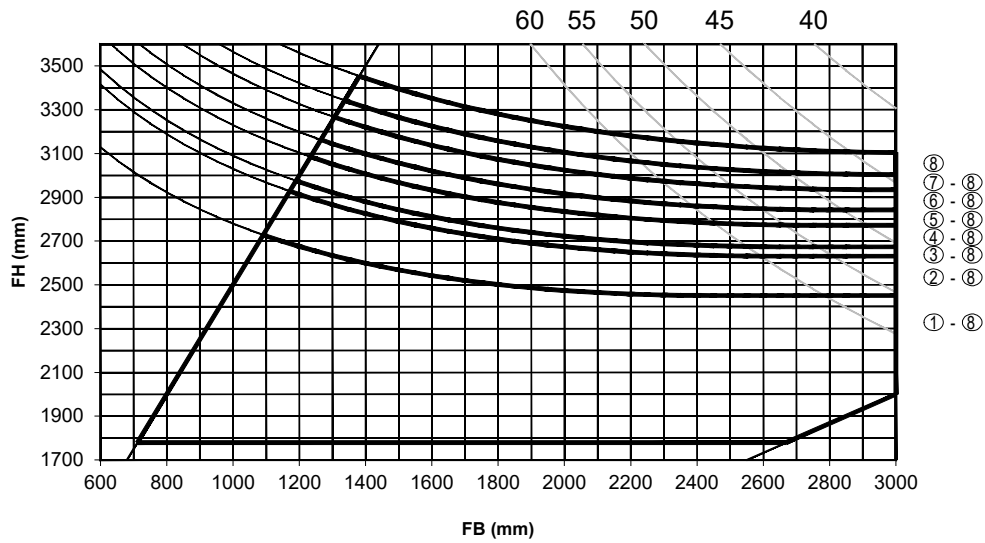

schaal - échelle  
 scale - Maßstab  
 1/2

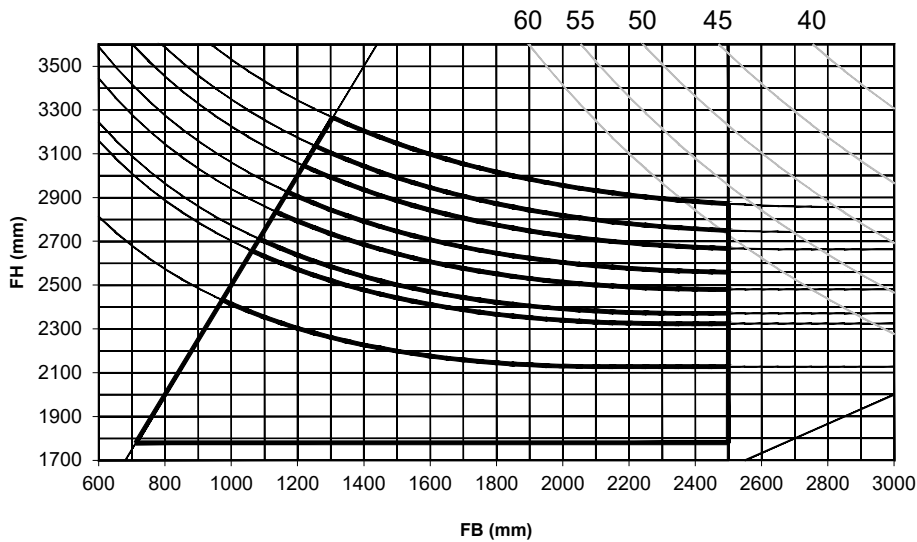
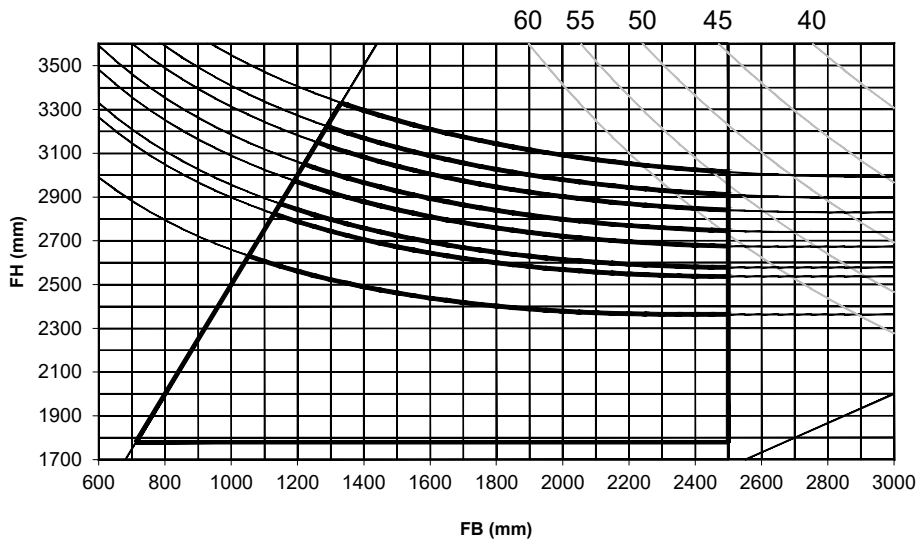
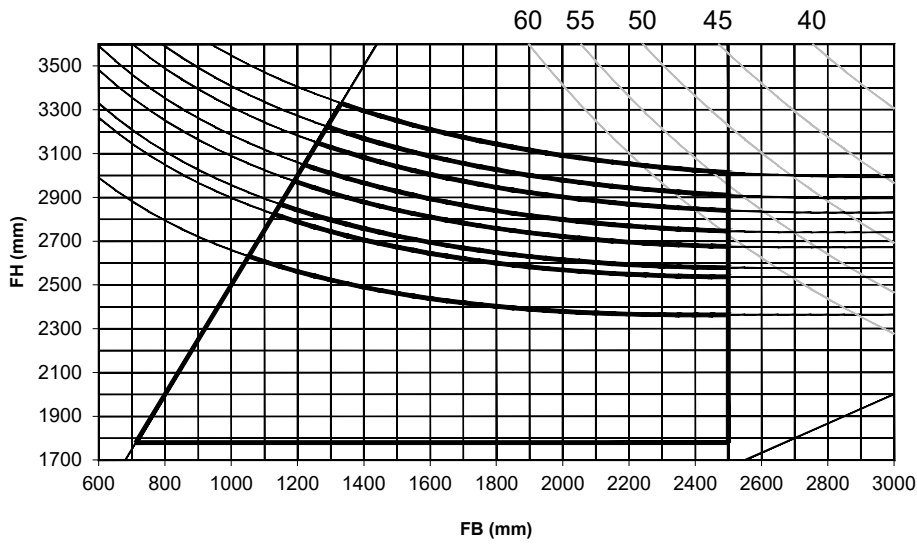

P = 1200Pa  
FG max = 400kg

P = WINDDRUK  
 P = PRESSION DU VENT  
 P = WINDDRUCK  
 P = WIND PRESSURE  
 FG = VLEUGELGEWICHT  
 FG = POIDS DU VANTAIL  
 FG = FLÜGELGEWICHT  
 FG = WEIGHT OF THE VENT  
 f = DOORBUIGING  
 f = FLEXION  
 f = DURCHBIEGUNG  
 f = DEFLECTION

schaal - échelle  
 scale - Maßstab  
 1/2

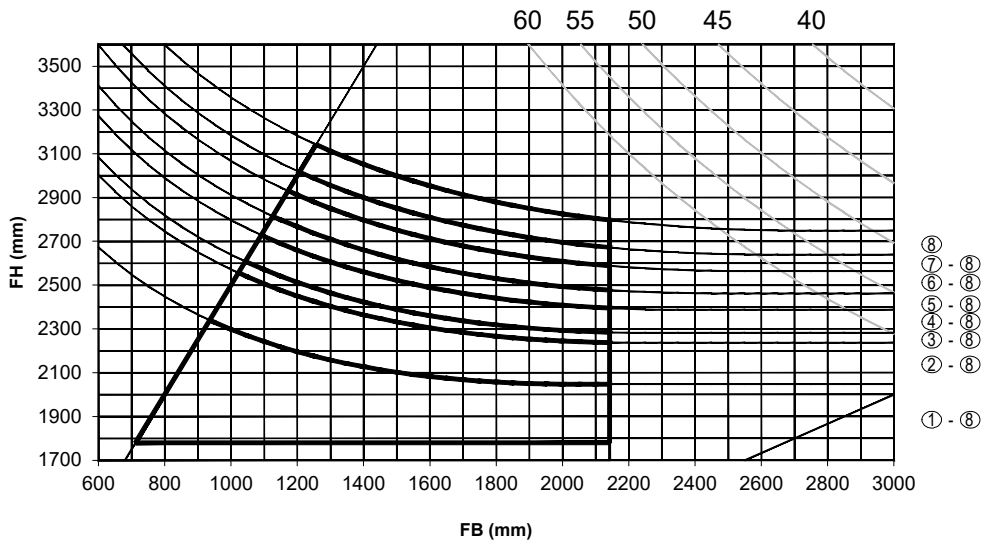
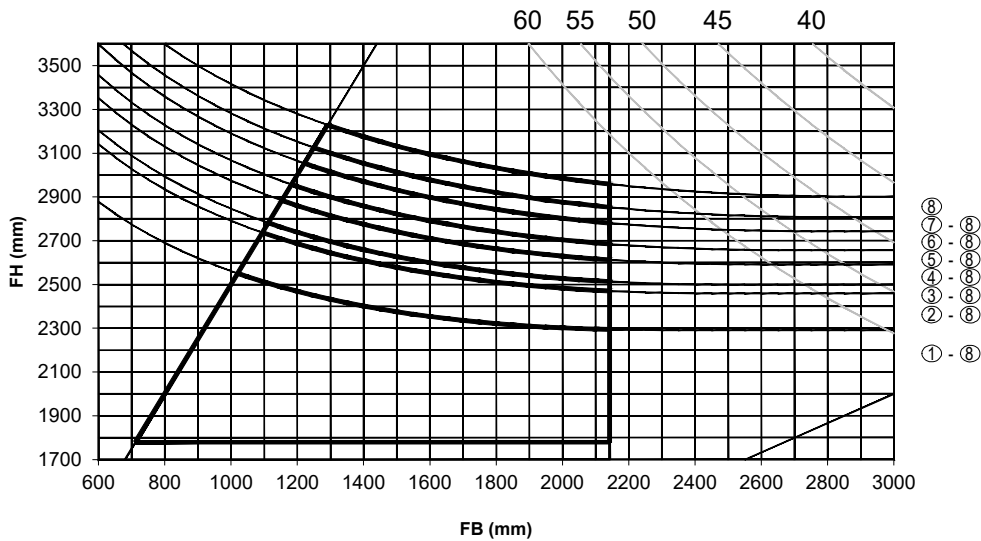
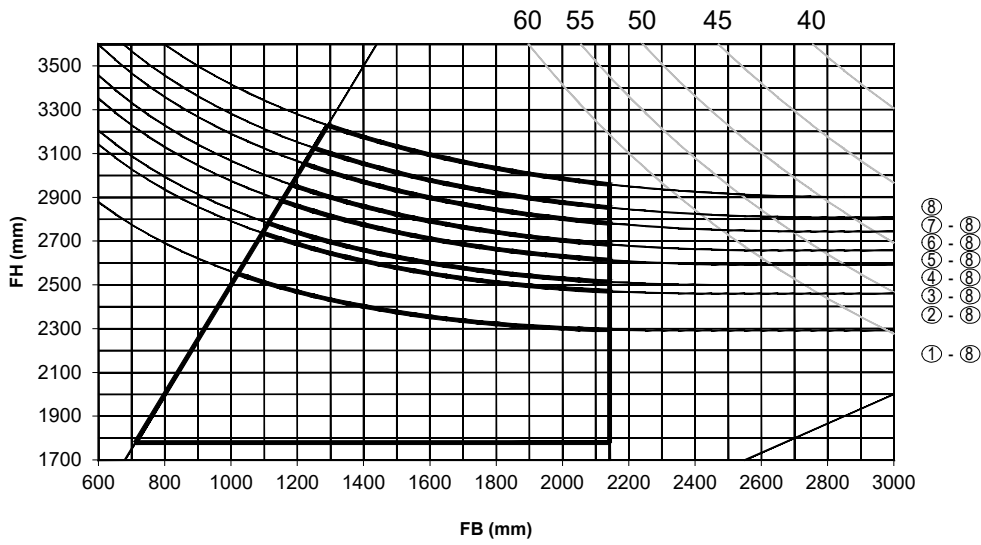

P = 1400Pa  
FG max = 400kg

P = WINDDRUK  
 P = PRESSION DU VENT  
 P = WINDDRUCK  
 P = WIND PRESSURE  
 FG = VLEUGELGEWICHT  
 FG = POIDS DU VAINTAIL  
 FG = FLÜGELGEWICHT  
 FG = WEIGHT OF THE VENT  
 f = DOORBUIGING  
 f = FLEXION  
 f = DURCHBIEGUNG  
 f = DEFLECTION

schaal - échelle  
 scale - Maßstab  
 1/2

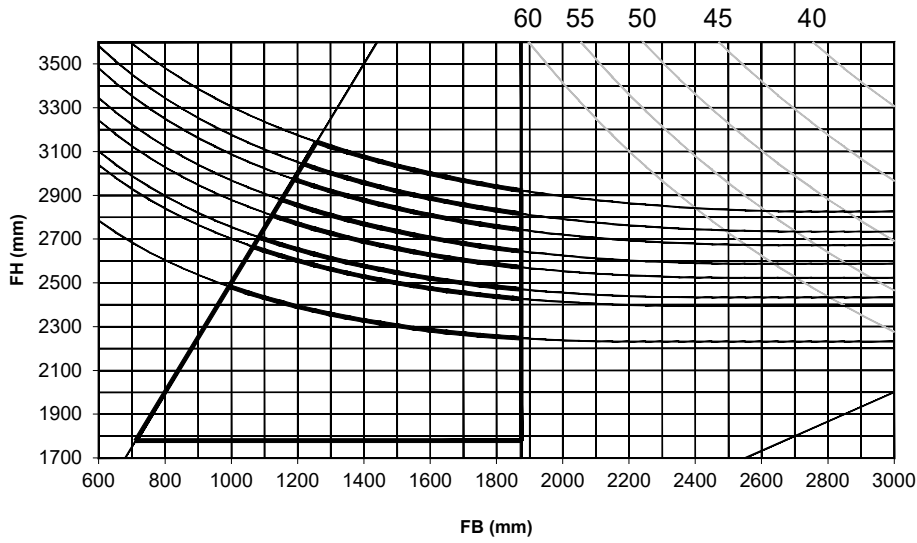

$f_{max} = H / 150$   
 max. 12mm

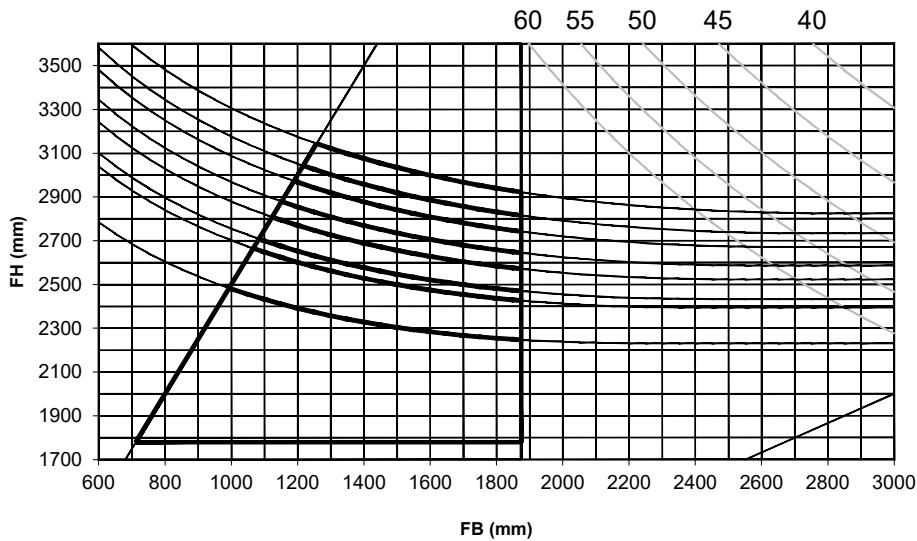

$f_{max} = H / 200$   
 max. 12mm

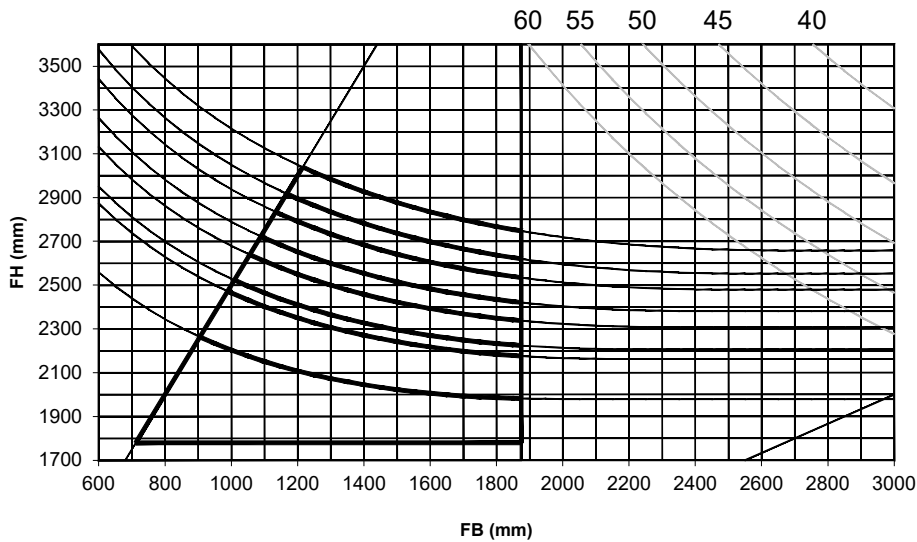

$f_{max} = H / 300$   
 max. 12mm

$P = 1600Pa$   
 $FG_{max} = 400kg$

P = WINDDRUK  
 P = PRESSION DU VENT  
 P = WINDRUCK  
 P = WIND PRESSURE  
 FG = VLEUGELGEWICHT  
 FG = POIDS DU VANTAIL  
 FG = FLÜGELGEWICHT  
 FG = WEIGHT OF THE VENT  
 f = DOORBUIGING  
 f = FLEXION  
 f = DURCHBIEGUNG  
 f = DEFLECTION

schaal - échelle  
 scale - Maßstab  
 1/2

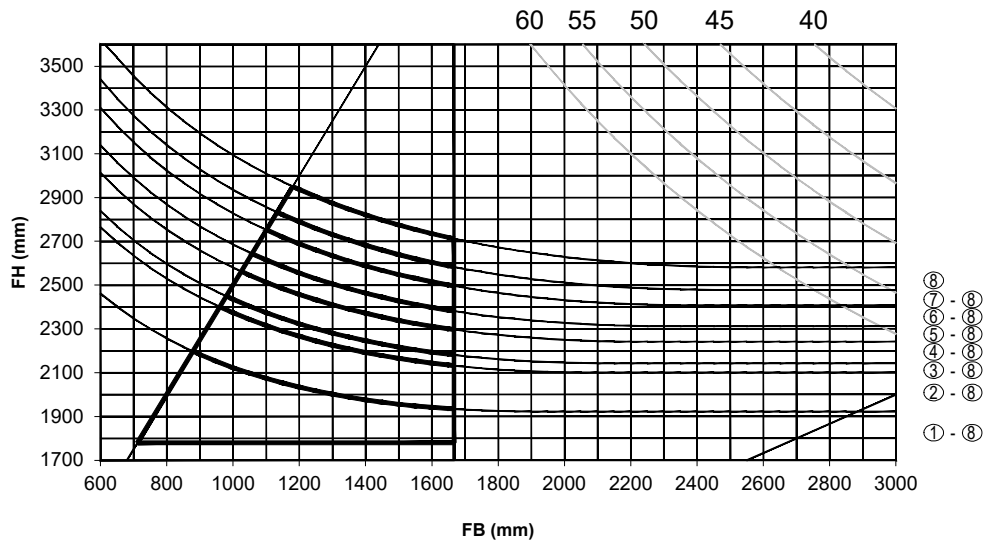
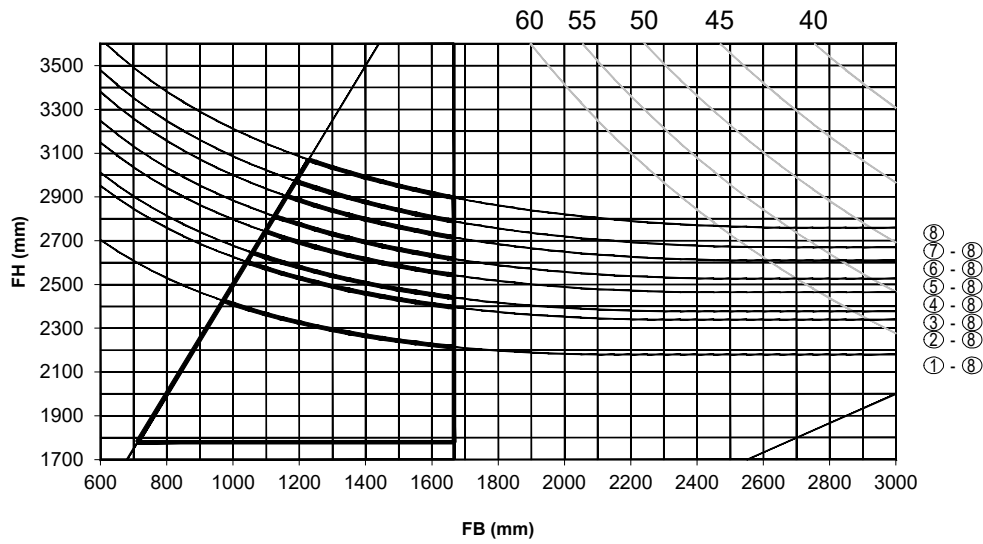
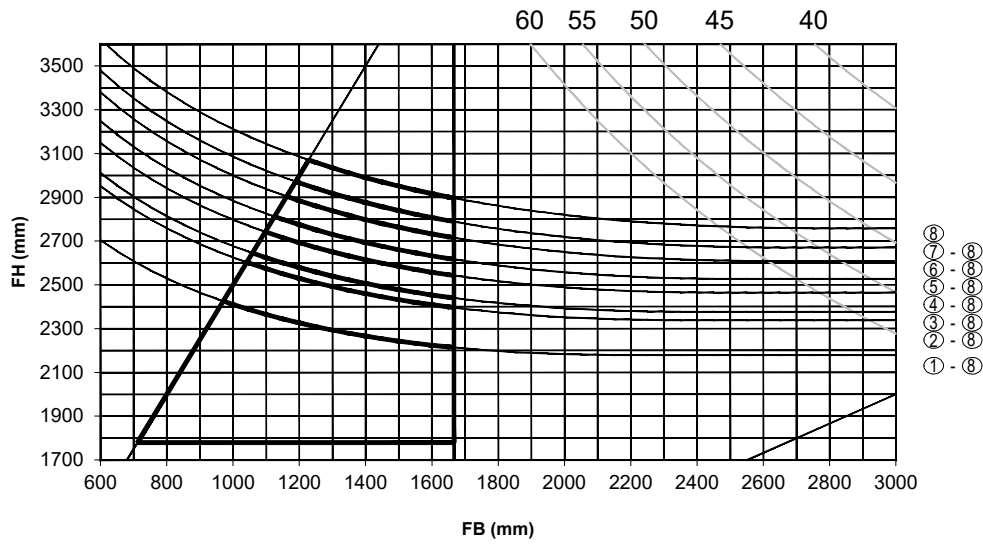

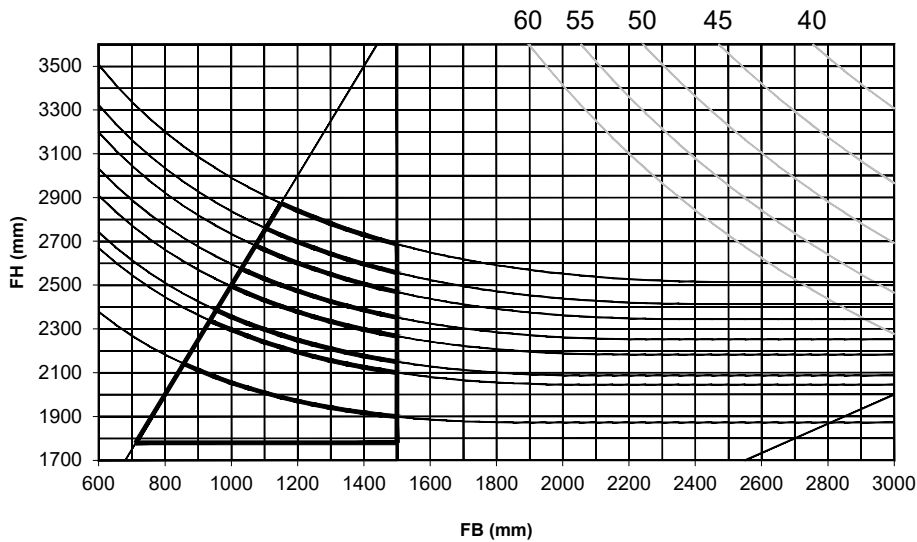
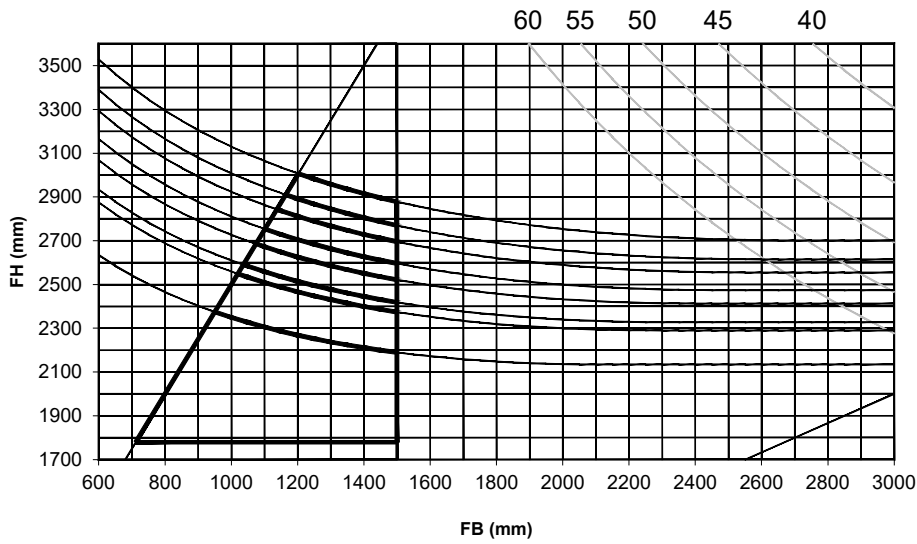
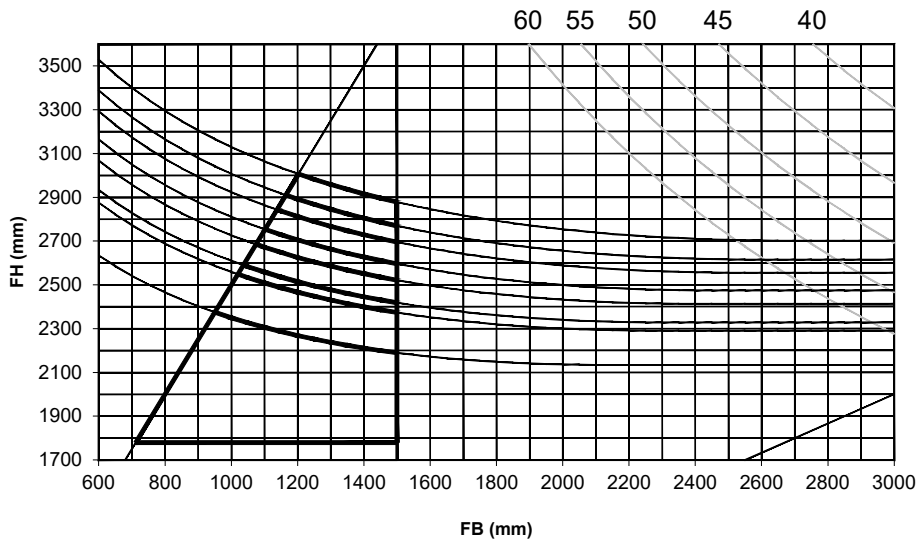

P = 2000Pa  
FG max = 400kg

P = WINDDRUK  
 P = PRESSION DU VENT  
 P = WINDRUCK  
 P = WIND PRESSURE  
 FG = VLEUGELGEWICHT  
 FG = POIDS DU VANTAIL  
 FG = FLÜGELGEWICHT  
 FG = WEIGHT OF THE VENT  
 f = DOORBUIGING  
 f = FLEXION  
 f = DURCHBIEGUNG  
 f = DEFLECTION

schaal - échelle  
 scale - Maßstab  
 1/2

①  
OG

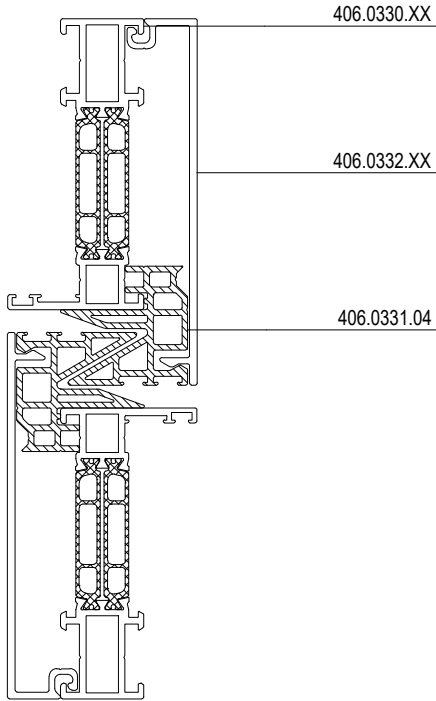

Total Ix = 116.4 cm<sup>4</sup>

①  
IG

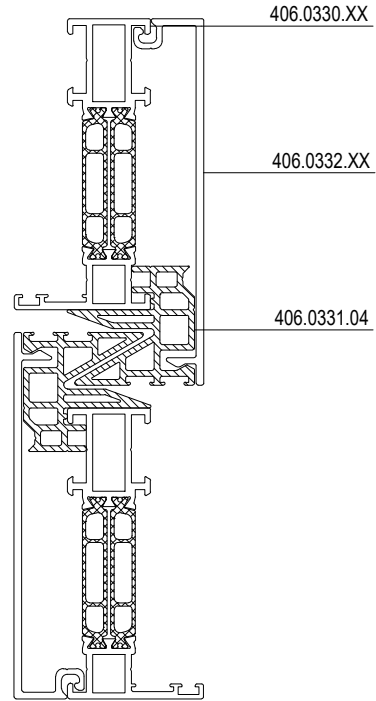

Total Ix = 116.4 cm<sup>4</sup>

①  
OG

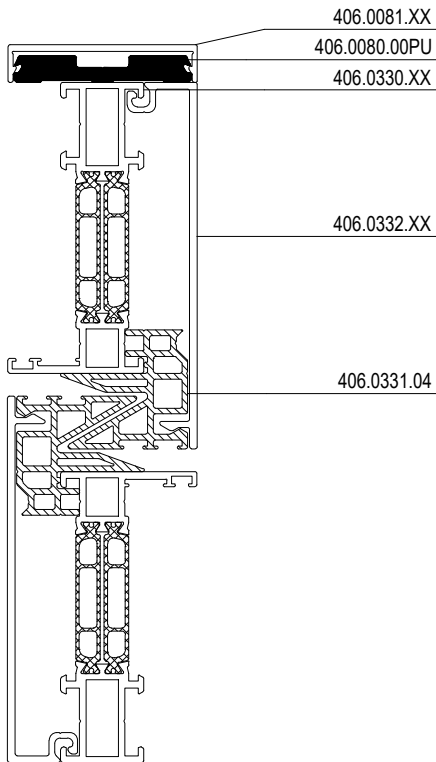

Total Ix = 120.0 cm<sup>4</sup>

①  
IG

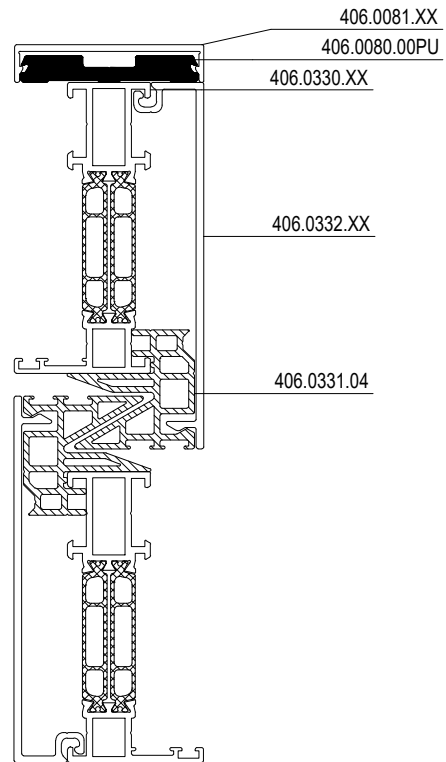

Total Ix = 120.0 cm<sup>4</sup>

②  
OG

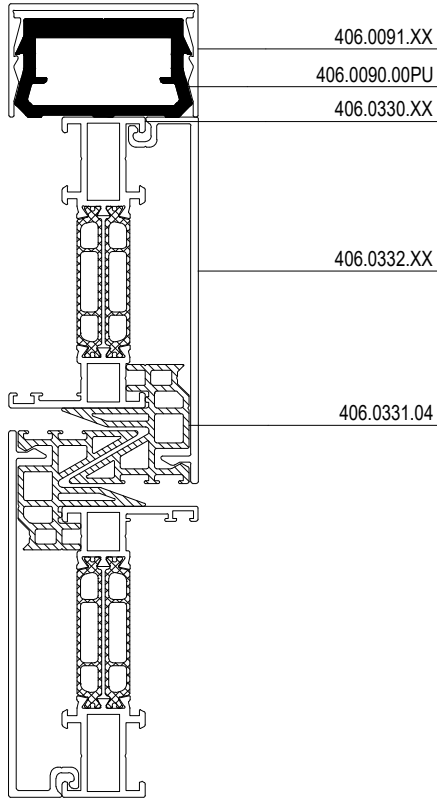

Total lx = 124.0 cm4

②  
IG

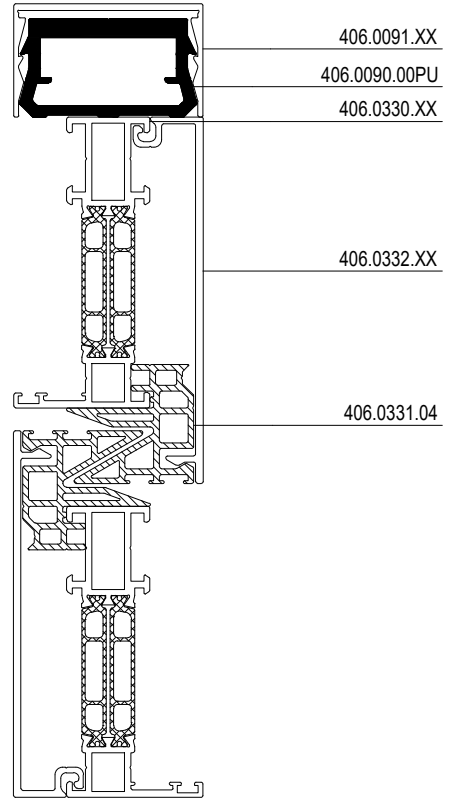

Total lx = 124.0 cm4

②  
OG

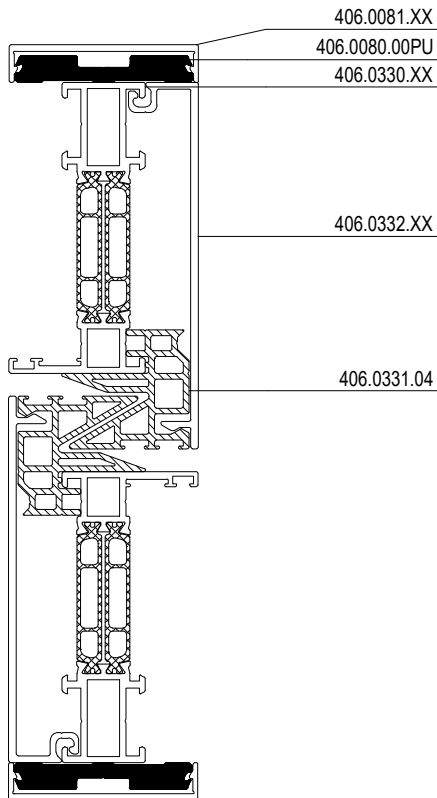

Total lx = 124.0 cm4

②  
IG

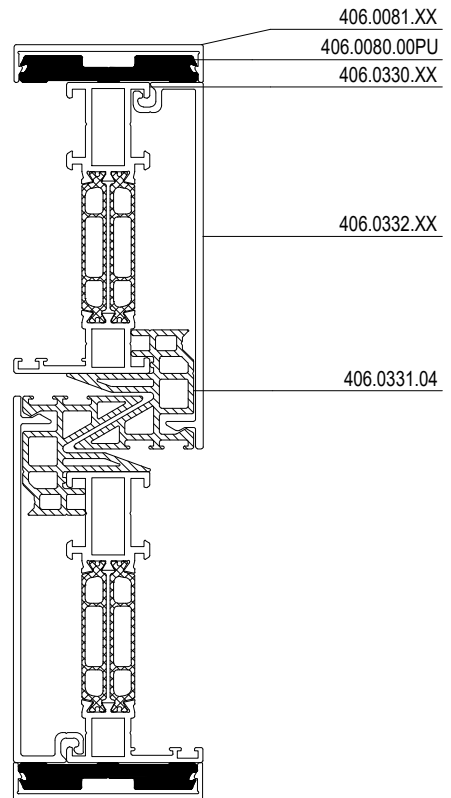

Total lx = 124.0 cm4

③  
OG

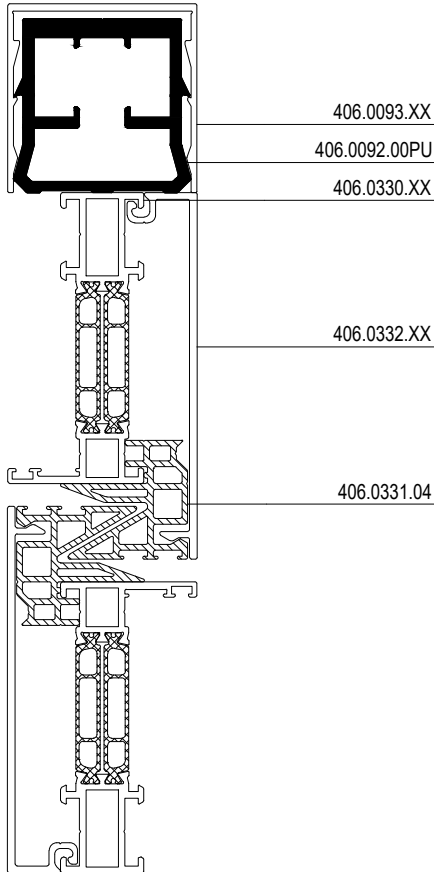

Total lx = 156.1 cm4

③  
IG

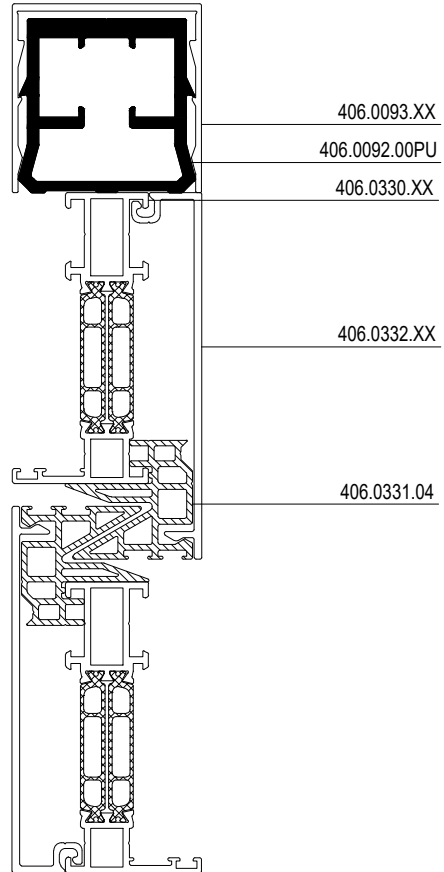

Total lx = 156.1 cm4

③  
OG

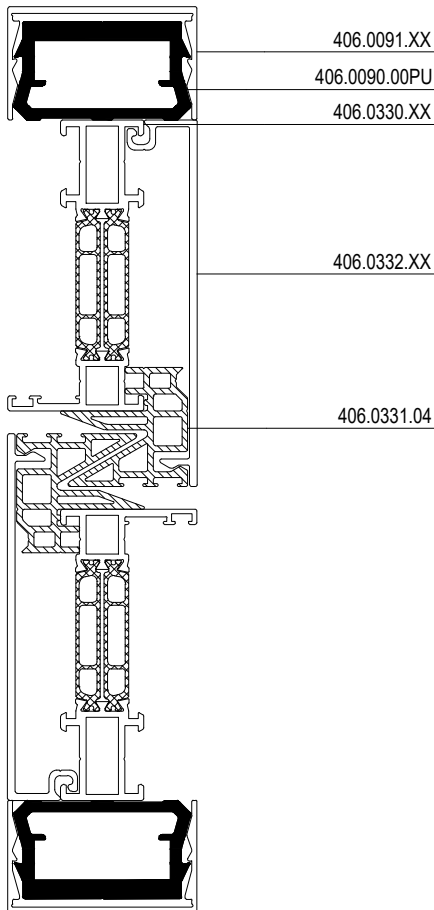

Total lx = 155.0 cm4

③  
IG

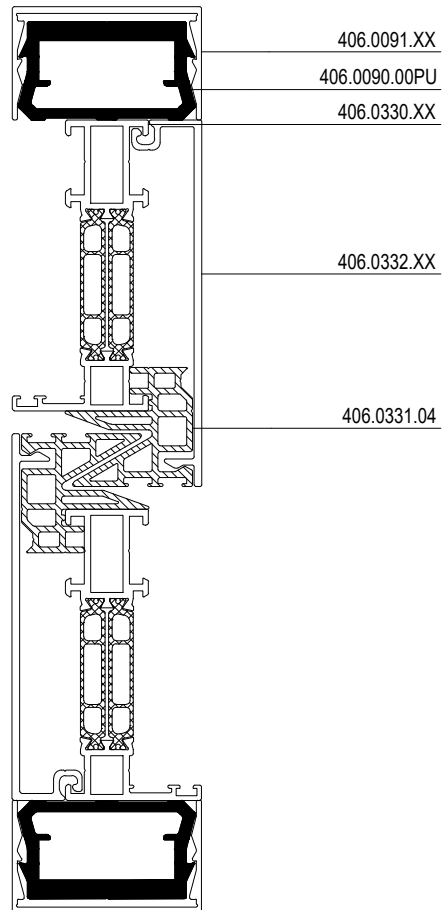

Total lx = 153.2 cm4

schaal - échelle  
 scale - Maßstab  
 1/2

④  
OG

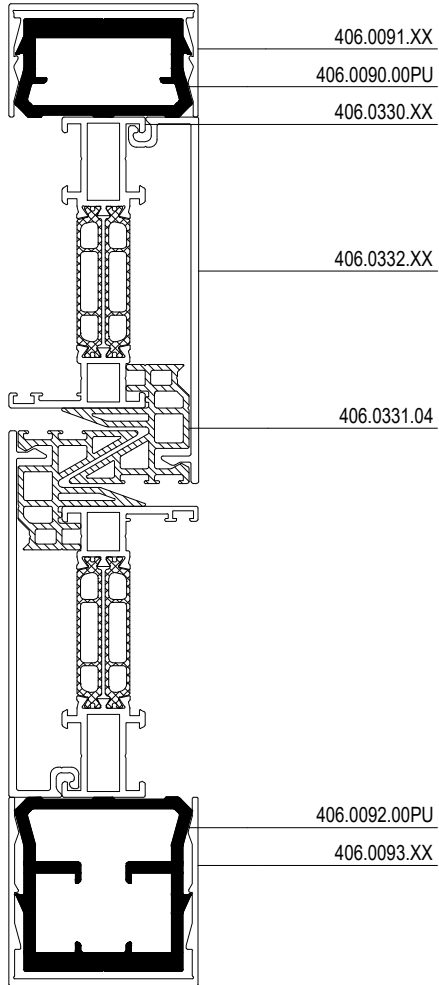

Total Ix = 187.1 cm<sup>4</sup>

④  
IG

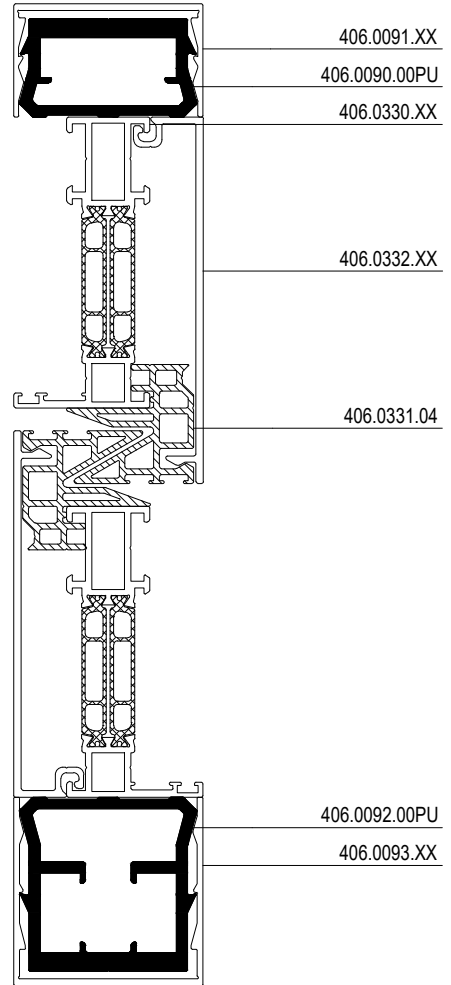

Total Ix = 184.6 cm<sup>4</sup>

F

5  
OG

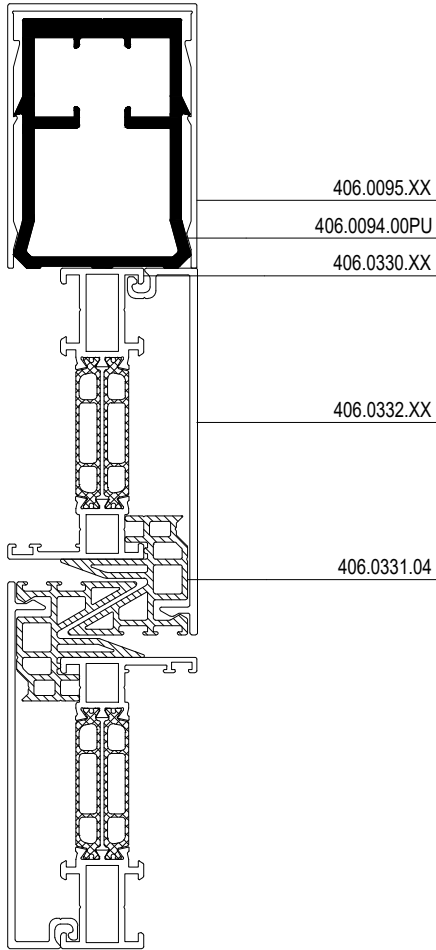

Total Ix = 203.9 cm<sup>4</sup>

5  
IG

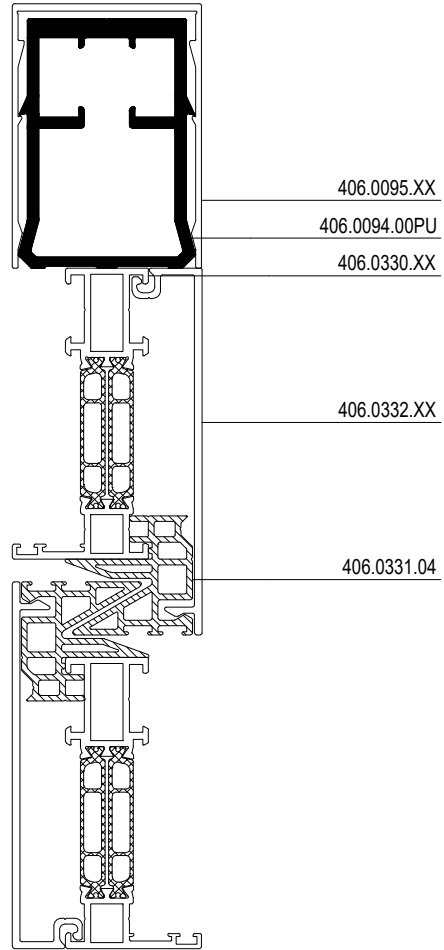

Total Ix = 203.9 cm<sup>4</sup>

⑥  
OG

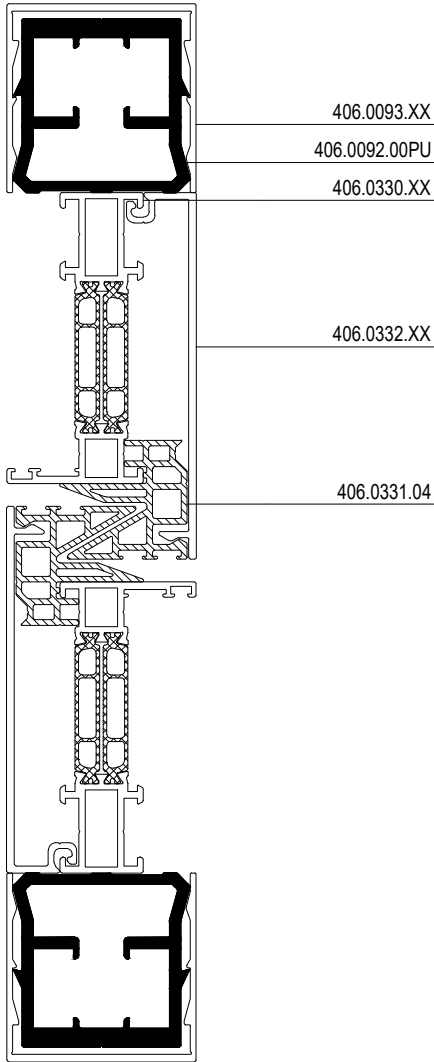

Total Ix = 219.2 cm<sup>4</sup>

⑥  
IG

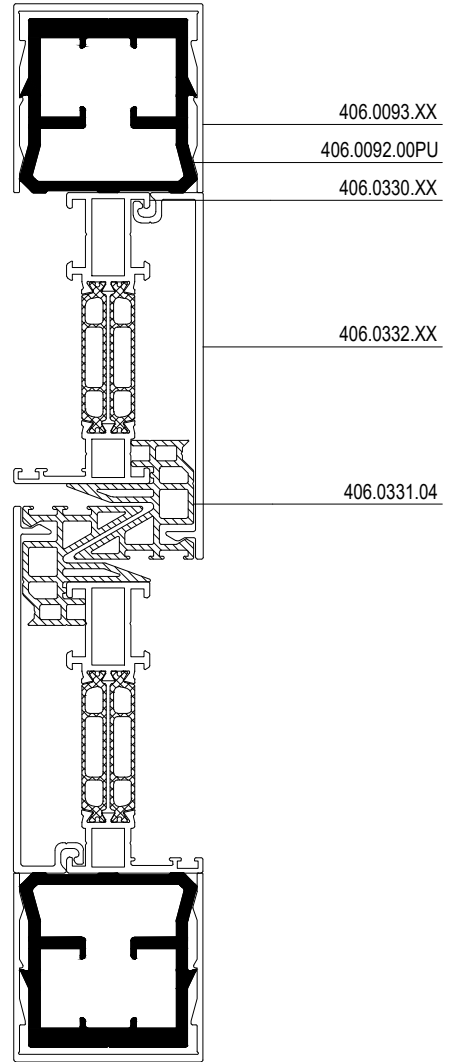

Total Ix = 216.7 cm<sup>4</sup>

F

7  
OG

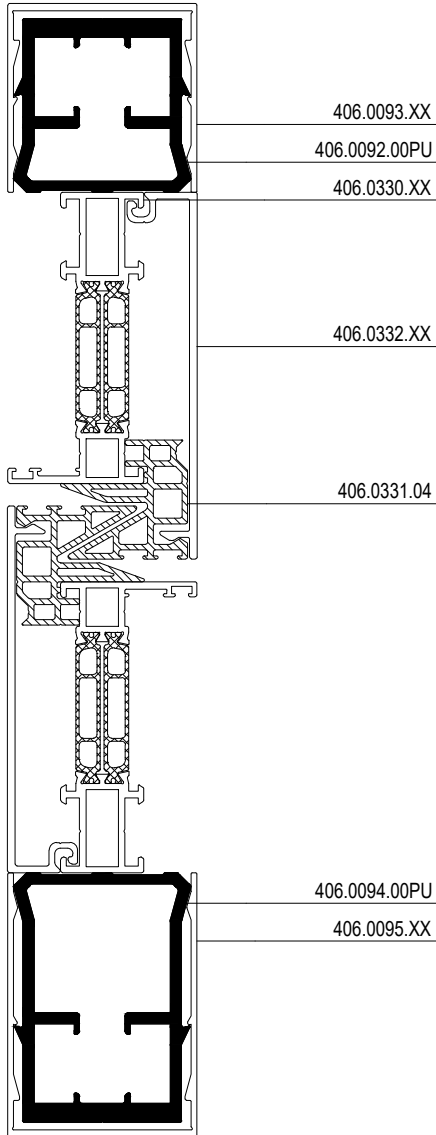

Total Ix = 240.3 cm<sup>4</sup>

7  
IG

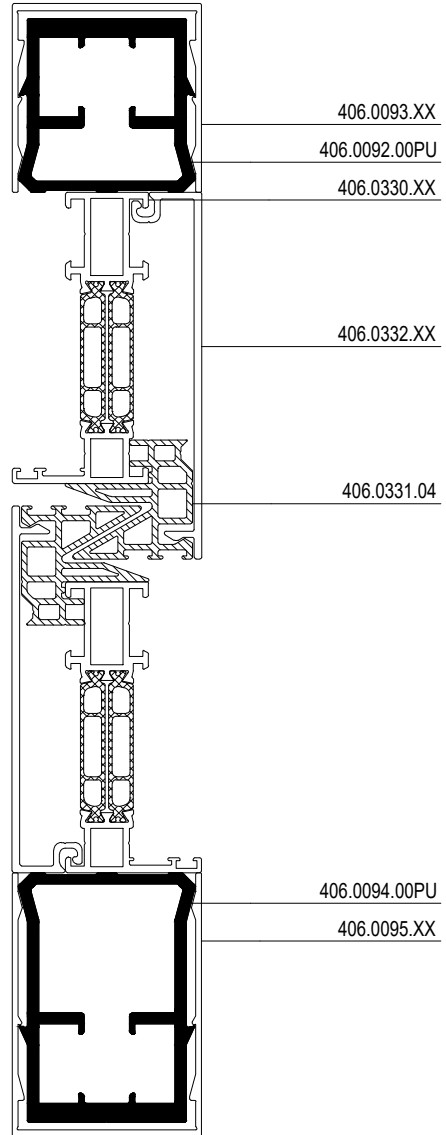

Total Ix = 237.5 cm<sup>4</sup>

8  
OG

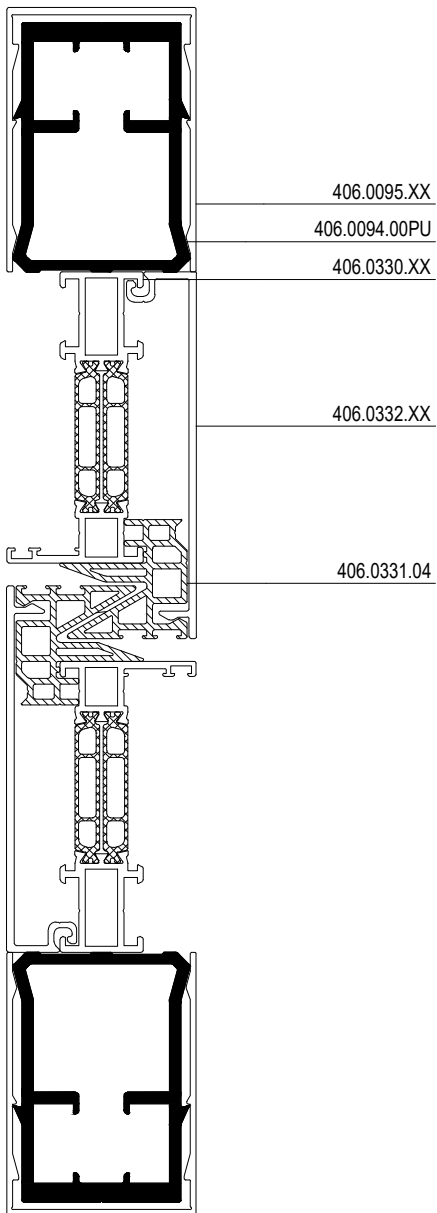

Total Ix = 283.3 cm<sup>4</sup>

8  
IG

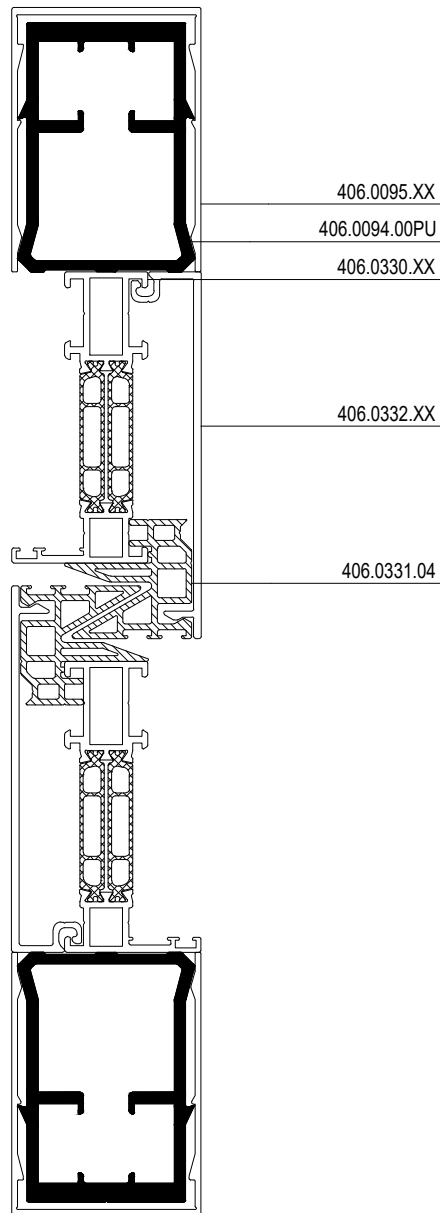

Total Ix = 280.5 cm<sup>4</sup>

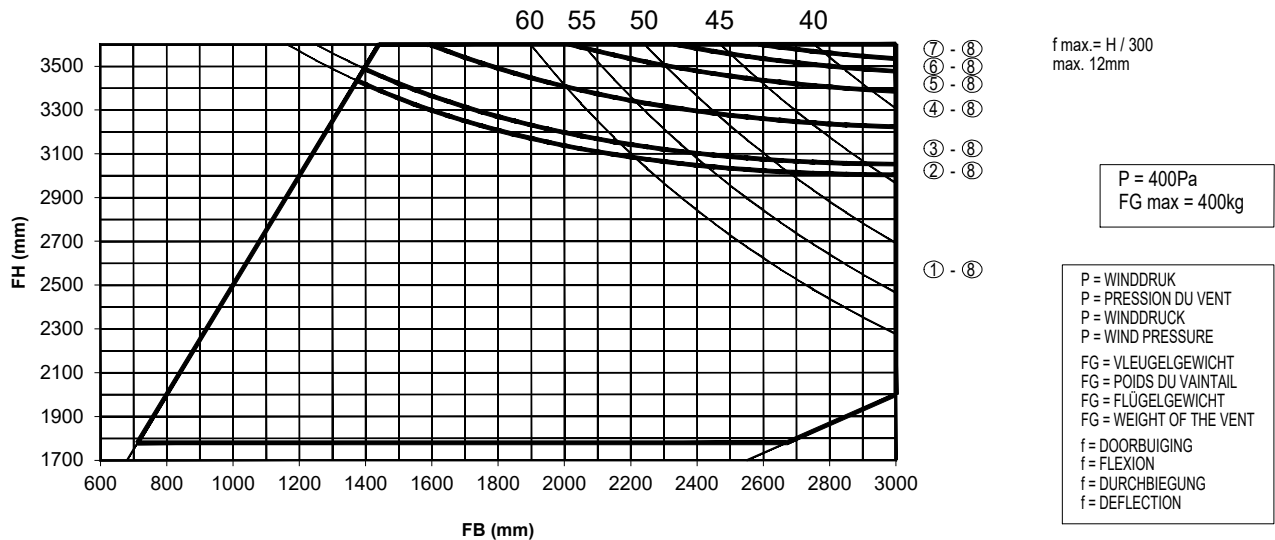
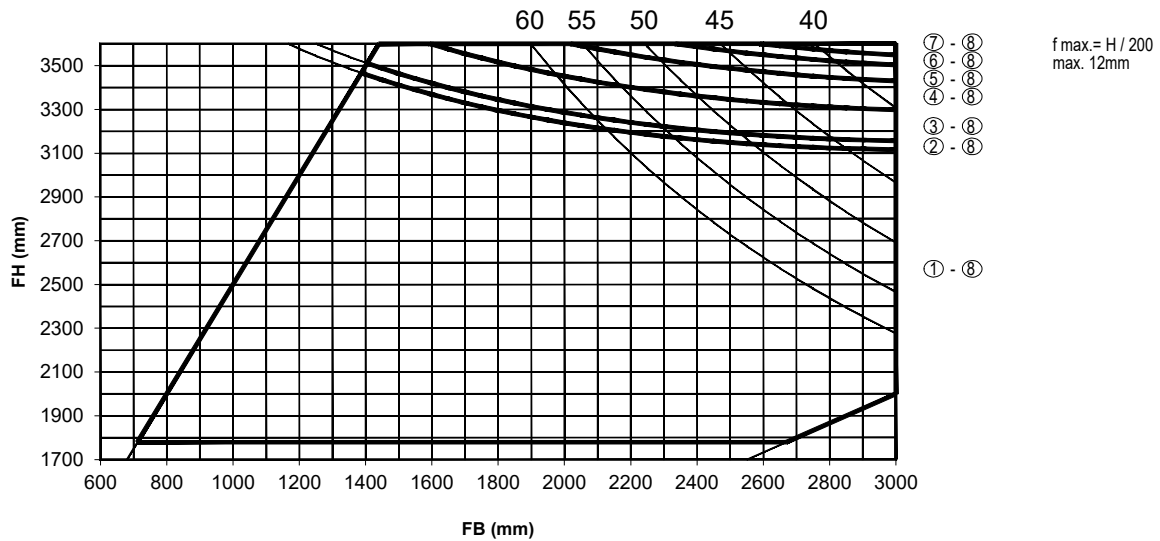
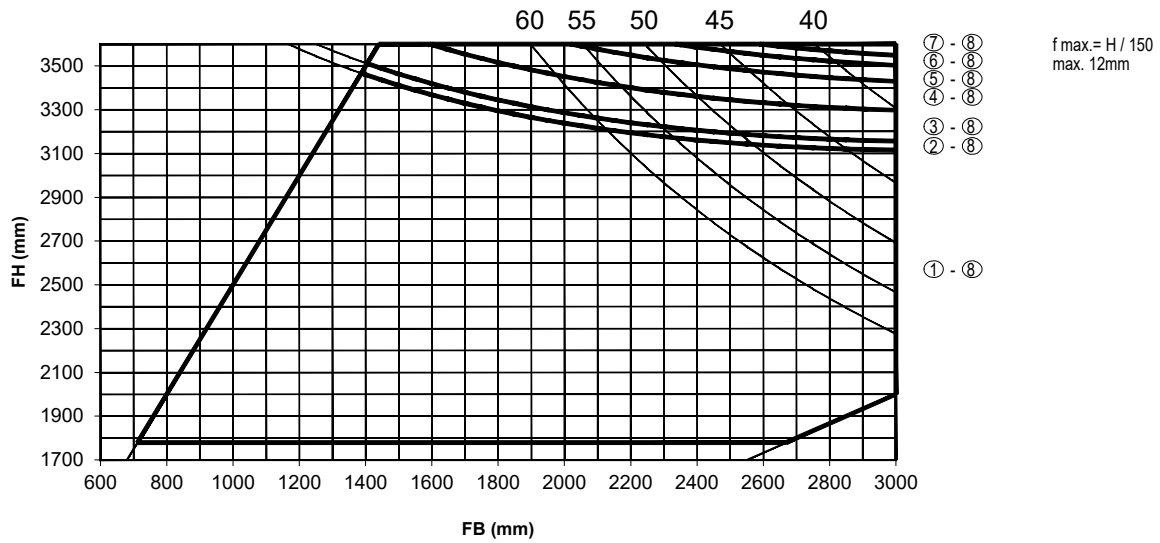

schaal - échelle  
 scale - Maßstab  
 1/2

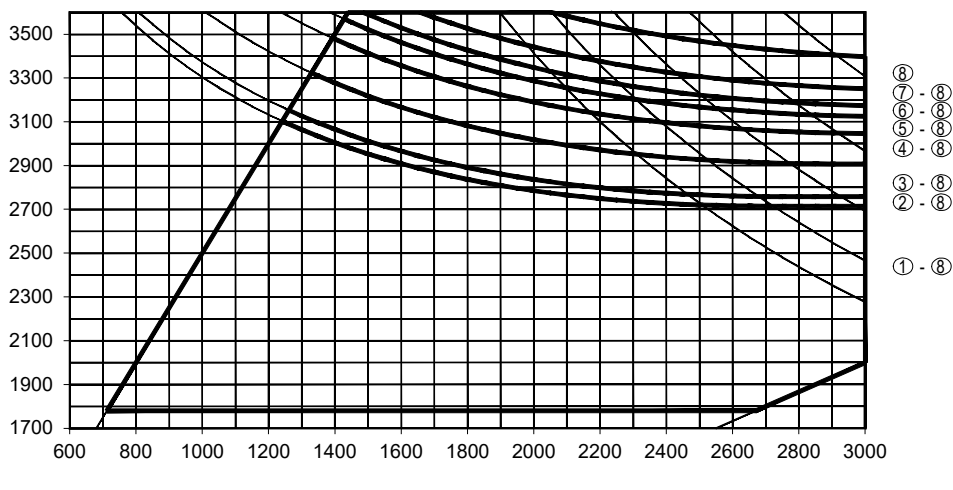
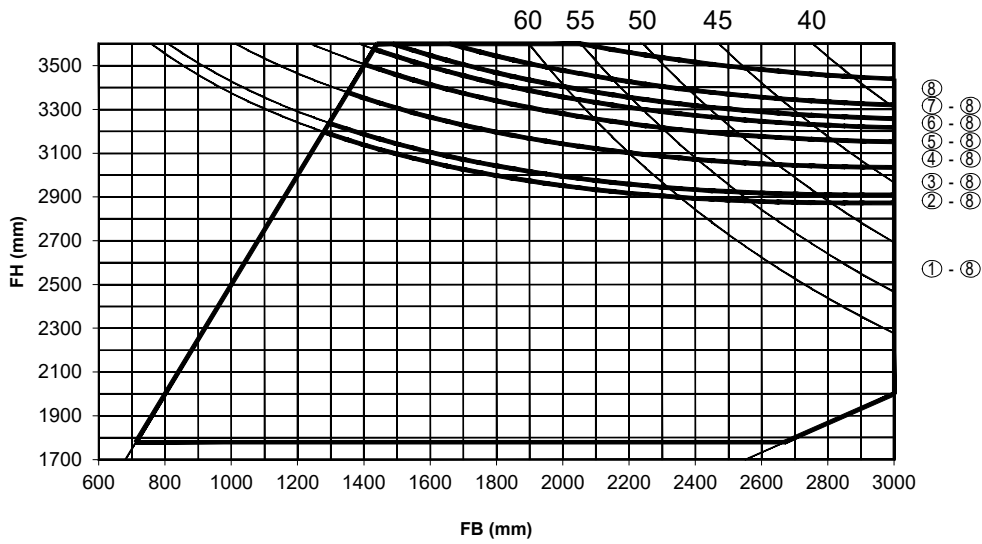
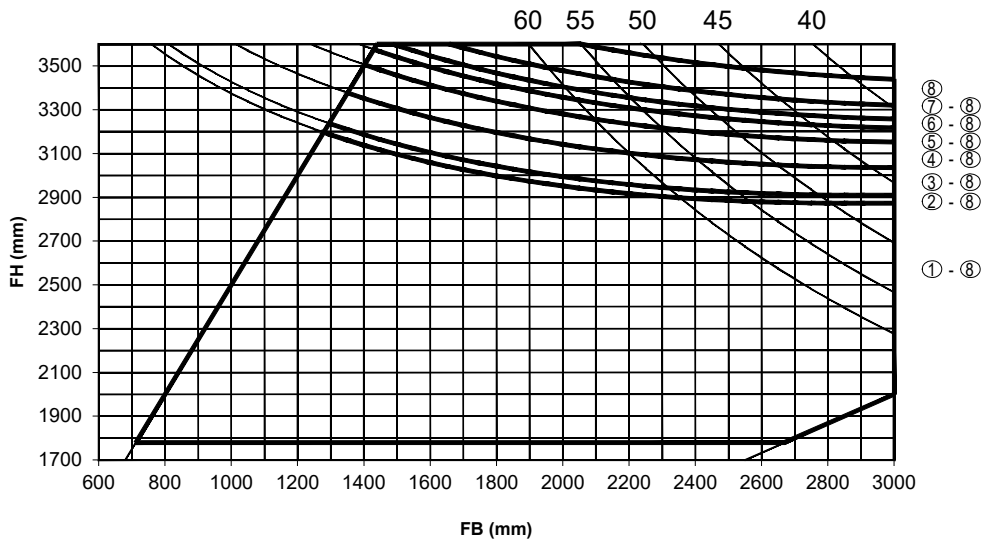

P = 600Pa  
 FG max = 400kg

P = WINDDRUK  
 P = PRESSION DU VENT  
 P = WINDDRUCK  
 P = WIND PRESSURE  
 FG = VLEUGELGEWICHT  
 FG = POIDS DU VANTAIL  
 FG = FLÜGELGEWICHT  
 FG = WEIGHT OF THE VENT  
 f = DOORBUIGING  
 f = FLEXION  
 f = DURCHBIEGUNG  
 f = DEFLECTION

schaal - échelle  
 scale - Maßstab  
 1/2

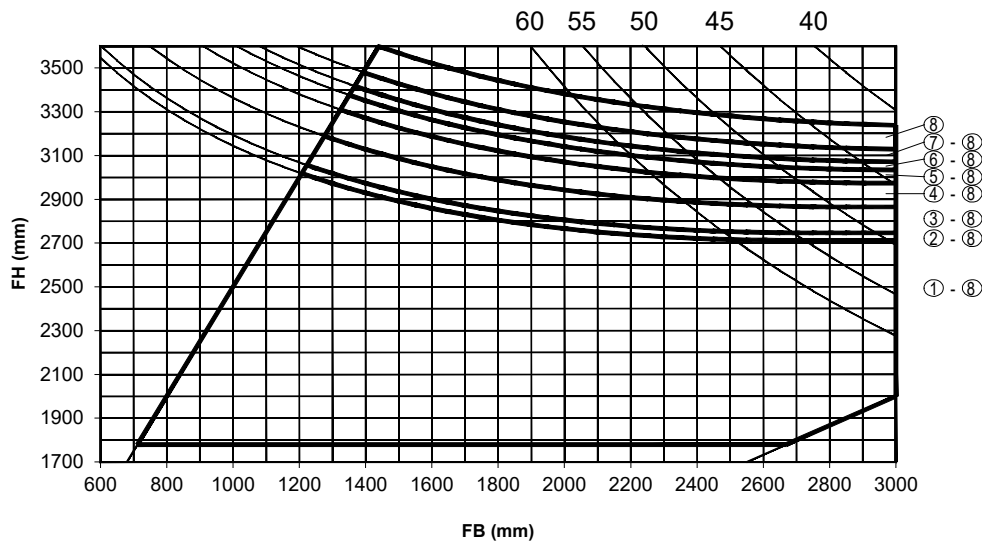

$f_{max} = H / 150$   
max. 12mm

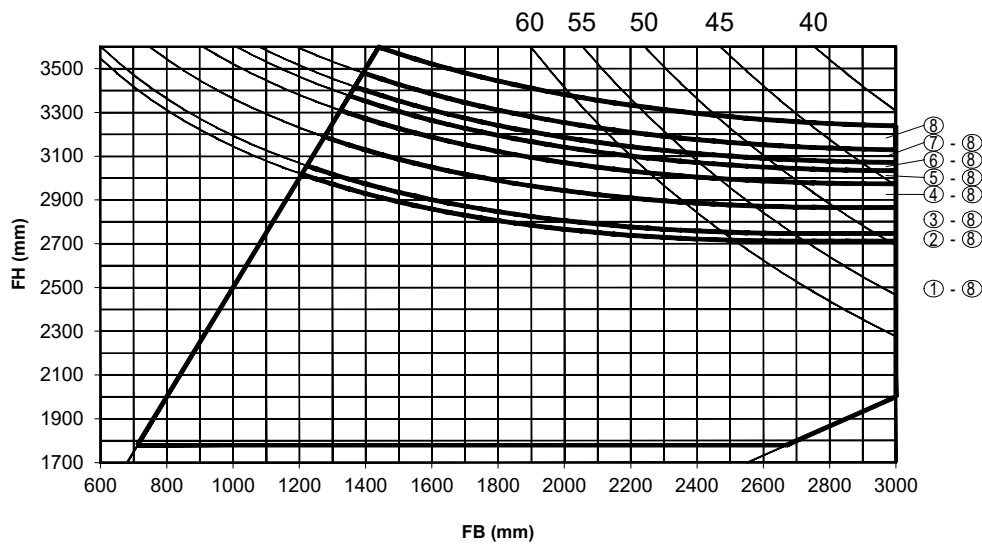

$f_{max} = H / 200$   
max. 12mm

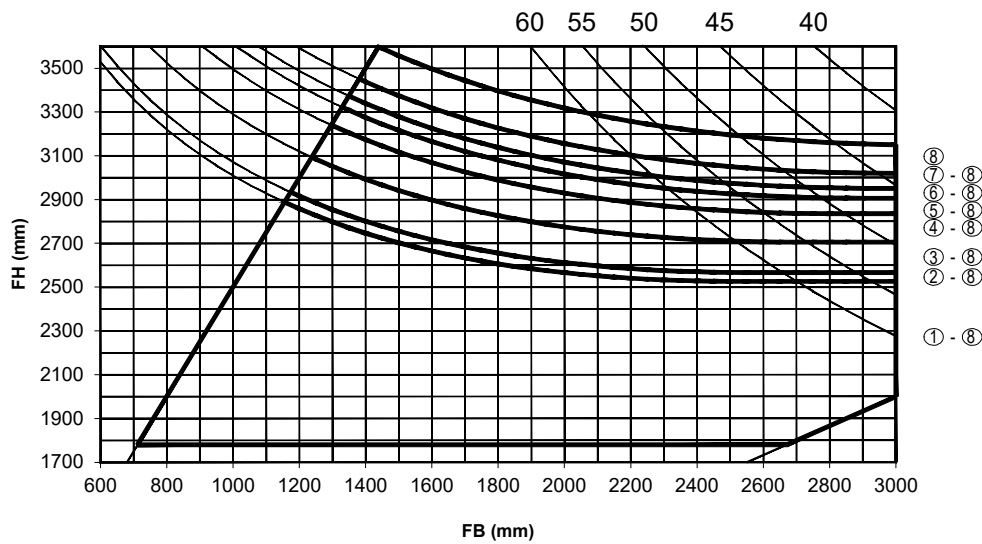

$f_{max} = H / 300$   
max. 12mm

P = 800Pa  
FG max = 400kg

P = WINDDRUK  
 P = PRESSION DU VENT  
 P = WINDDRUCK  
 P = WIND PRESSURE  
 FG = VLEUGELGEWICHT  
 FG = POIDS DU VAINTAIL  
 FG = FLÜGELGEWICHT  
 FG = WEIGHT OF THE VENT  
 f = DOORBUIGING  
 f = FLEXION  
 f = DURCHBIEGUNG  
 f = DEFLECTION

schaal - échelle  
 scale - Maßstab  
 1/2

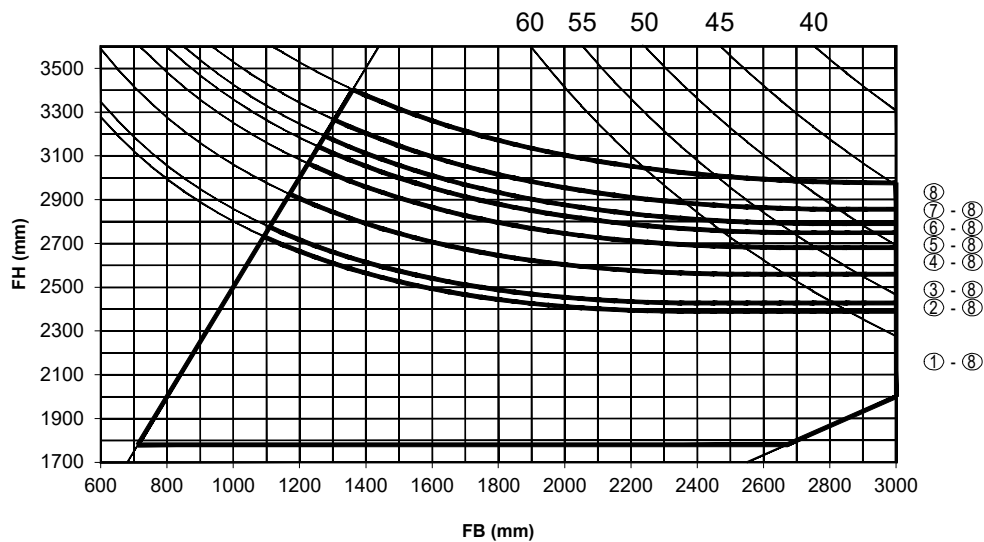
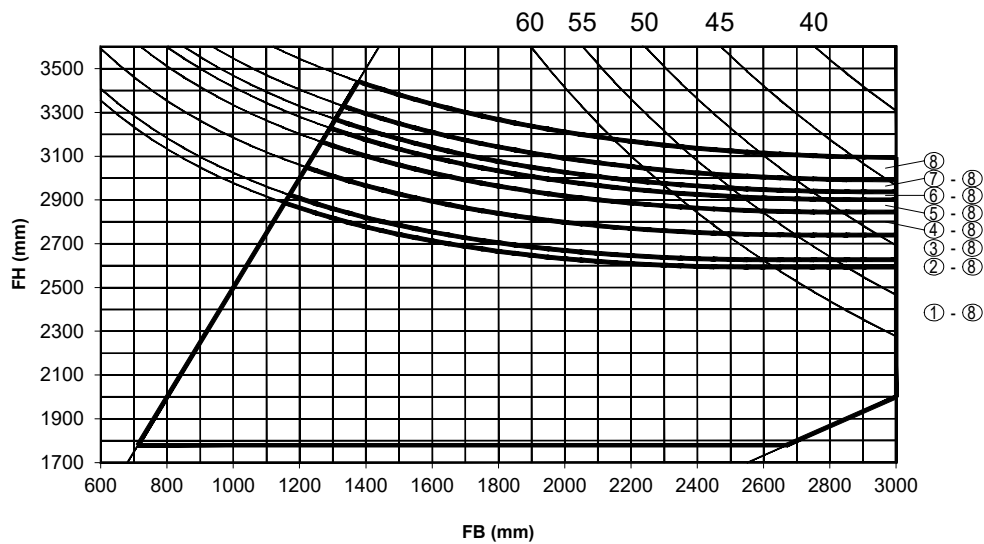
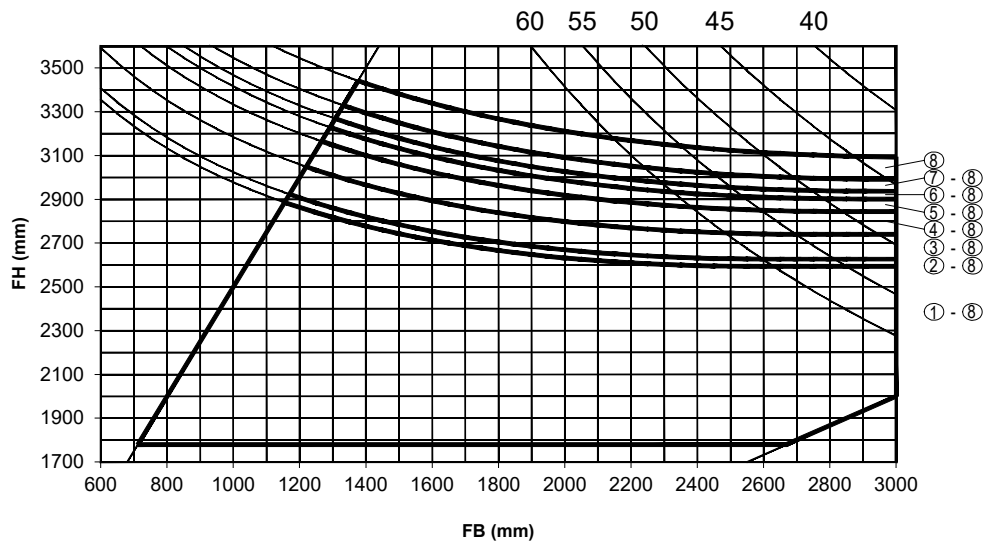

P = 1000Pa  
FG max = 400kg

P = WINDDRUK  
 P = PRESSION DU VENT  
 P = WINDRUCK  
 P = WIND PRESSURE  
 FG = VLEUGELGEWICHT  
 FG = POIDS DU VANTAIL  
 FG = FLÜGELGEWICHT  
 FG = WEIGHT OF THE VENT  
 f = DOORBUIGING  
 f = FLEXION  
 f = DURCHBIEGUNG  
 f = DEFLECTION

schaal - échelle  
 scale - Maßstab  
 1/2

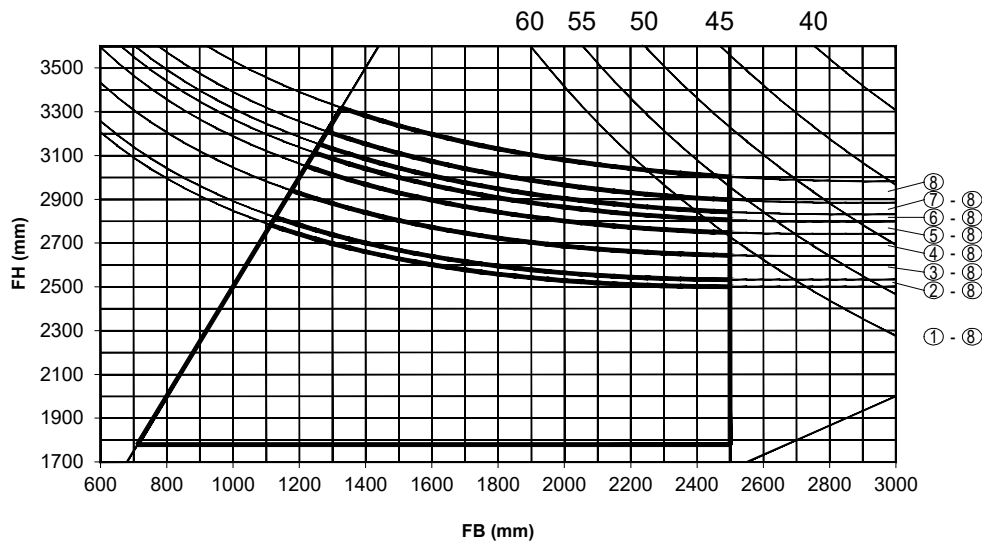

$f_{max} = H / 150$   
 max. 12mm

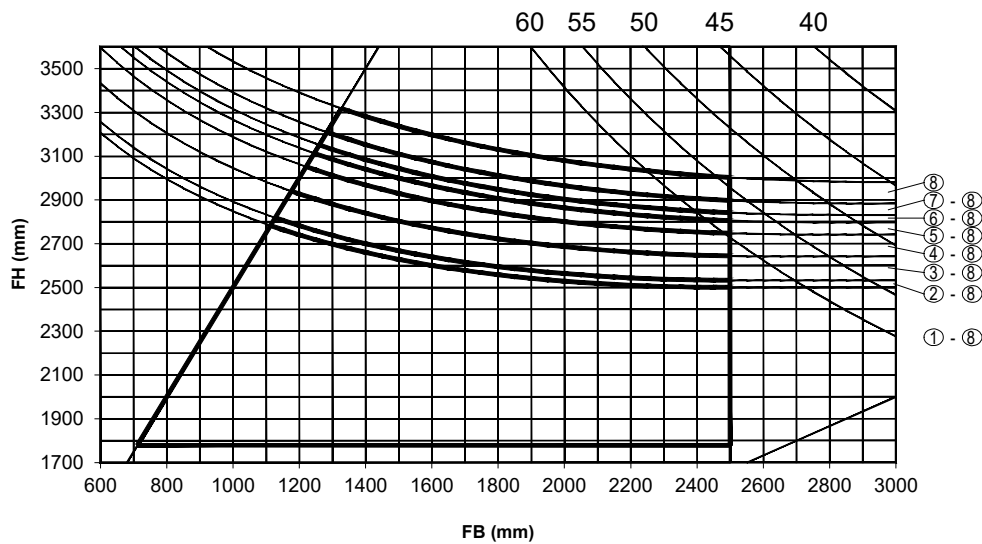

$f_{max} = H / 200$   
 max. 12mm

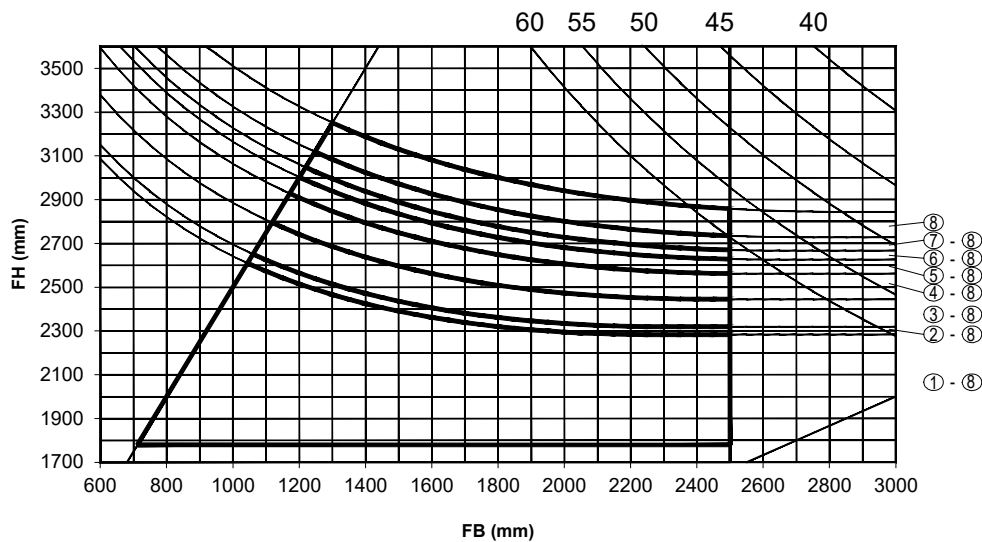

$f_{max} = H / 300$   
 max. 12mm

$P = 1200Pa$   
 $FG_{max} = 400kg$

P = WINDDRUK  
 P = PRESSION DU VENT  
 P = WINDDRUCK  
 P = WIND PRESSURE  
 FG = VLEUGELGEWICHT  
 FG = POIDS DU VANTAIL  
 FG = FLÜGELGEWICHT  
 FG = WEIGHT OF THE VENT  
 f = DOORBUIGING  
 f = FLEXION  
 f = DURCHBIEGUNG  
 f = DEFLECTION

schaal - échelle  
 scale - Maßstab  
 1/2

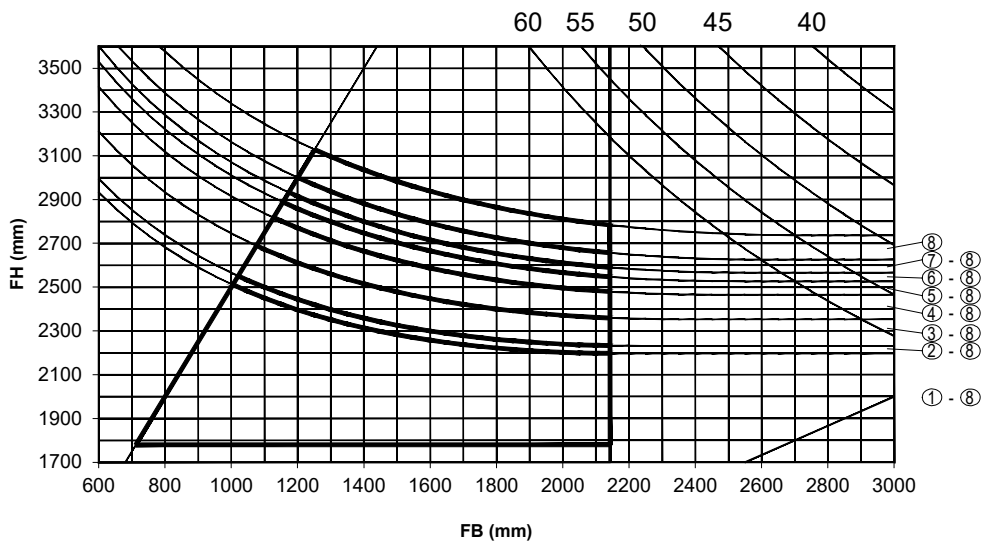
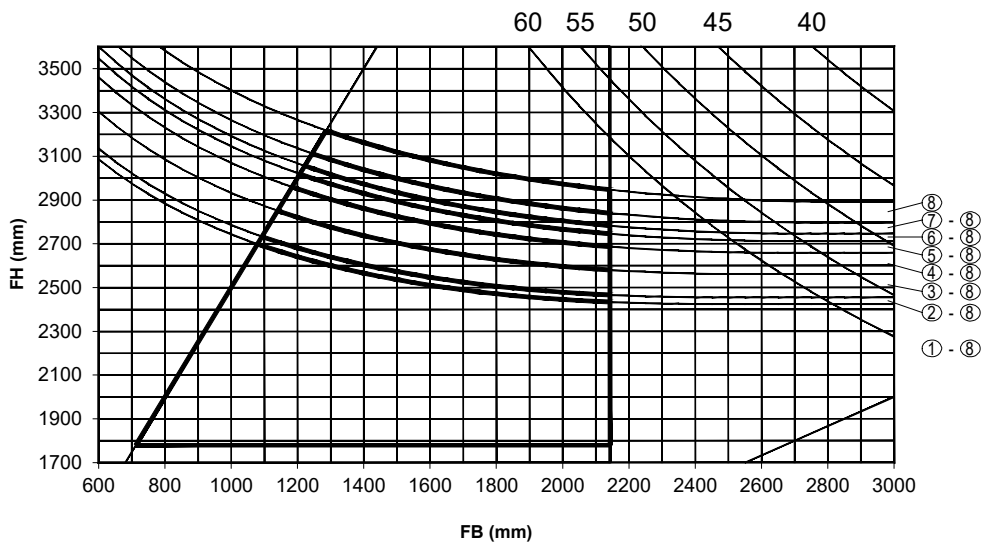
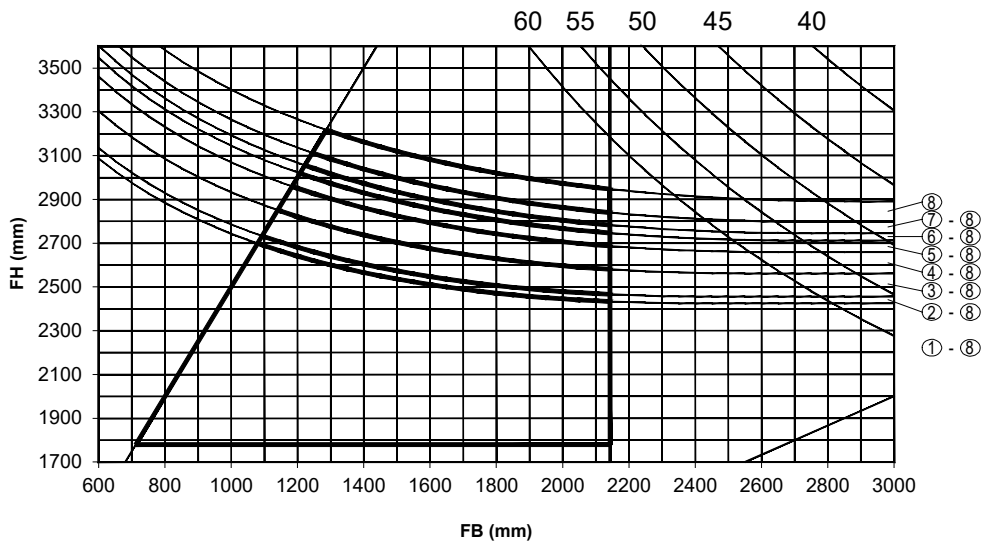

P = 1400Pa  
FG max = 400kg

P = WINDDRUK  
 P = PRESSION DU VENT  
 P = WINDRUCK  
 P = WIND PRESSURE  
 FG = VLEUGELGEWICHT  
 FG = POIDS DU VANTAIL  
 FG = FLÜGELGEWICHT  
 FG = WEIGHT OF THE VENT  
 f = DOORBUIGING  
 f = FLEXION  
 f = DURCHBIEGUNG  
 f = DEFLECTION

schaal - échelle  
 scale - Maßstab  
 1/2

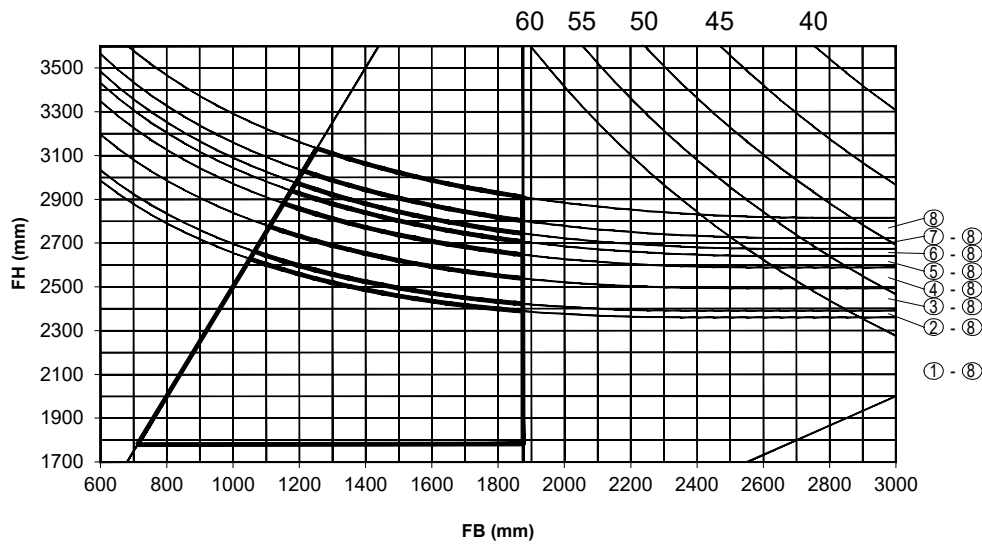

$f_{max} = H / 150$   
max. 12mm

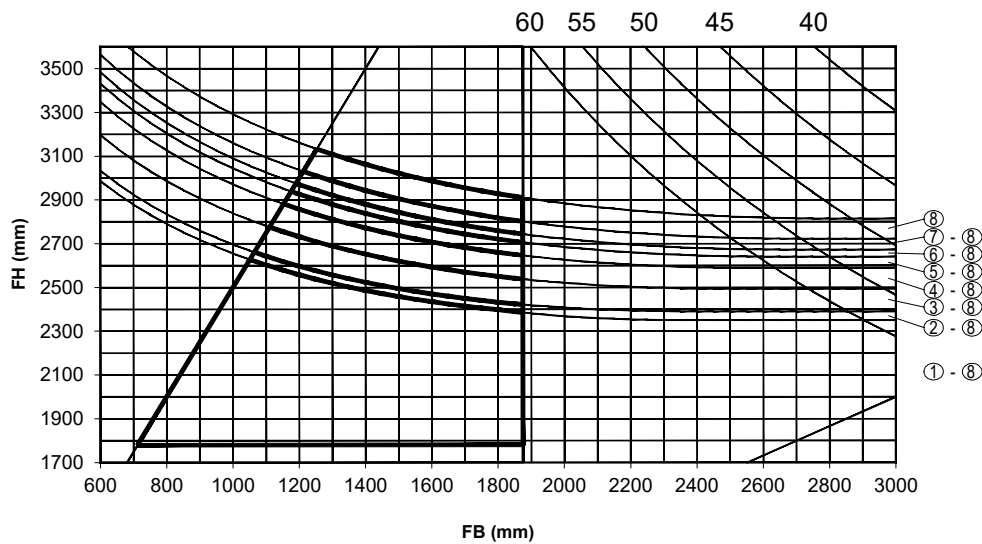

$f_{max} = H / 200$   
max. 12mm

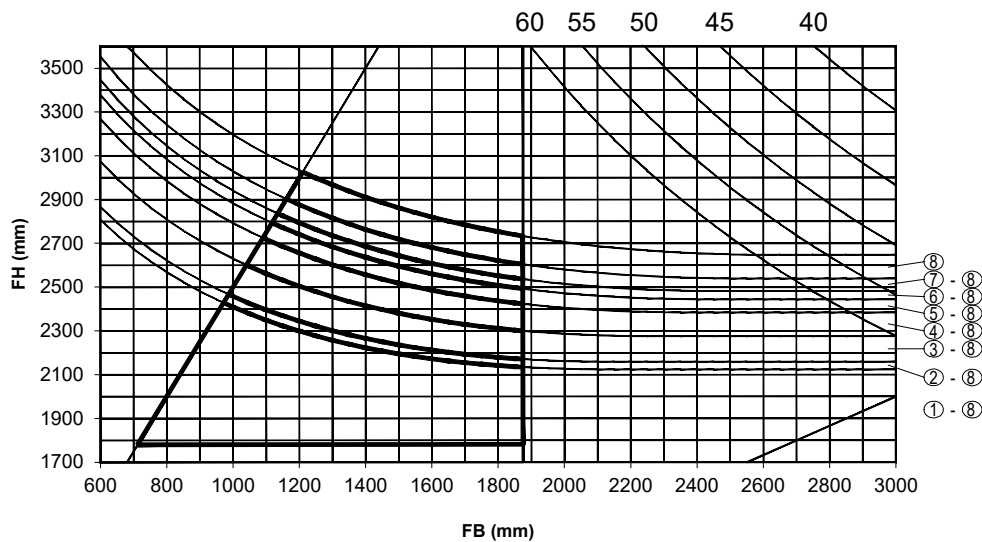

$f_{max} = H / 300$   
max. 12mm

P = 1600Pa  
FG max = 400kg

P = WINDDRUK  
 P = PRESSION DU VENT  
 P = WINDDRUCK  
 P = WIND PRESSURE  
 FG = VLEUGELGEWICHT  
 FG = POIDS DU VAINTAIL  
 FG = FLÜGELGEWICHT  
 FG = WEIGHT OF THE VENT  
 f = DOORBUIGING  
 f = FLEXION  
 f = DURCHBIEGUNG  
 f = DEFLECTION

schaal - échelle  
 scale - Maßstab  
 1/2

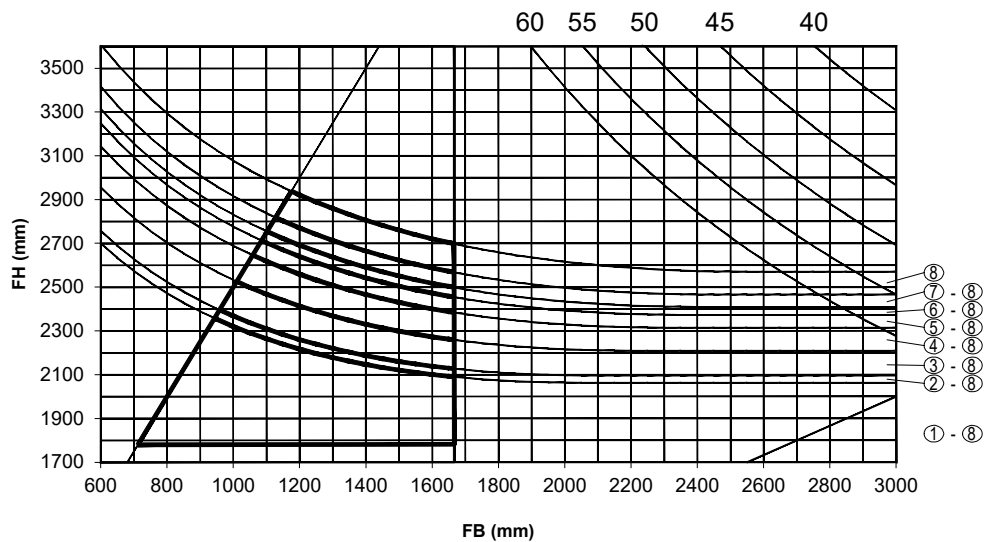
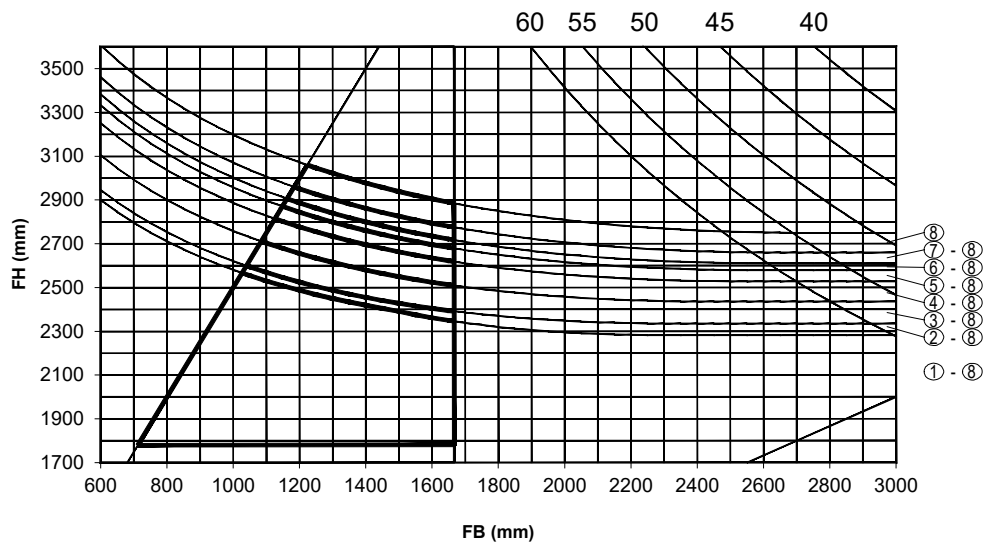
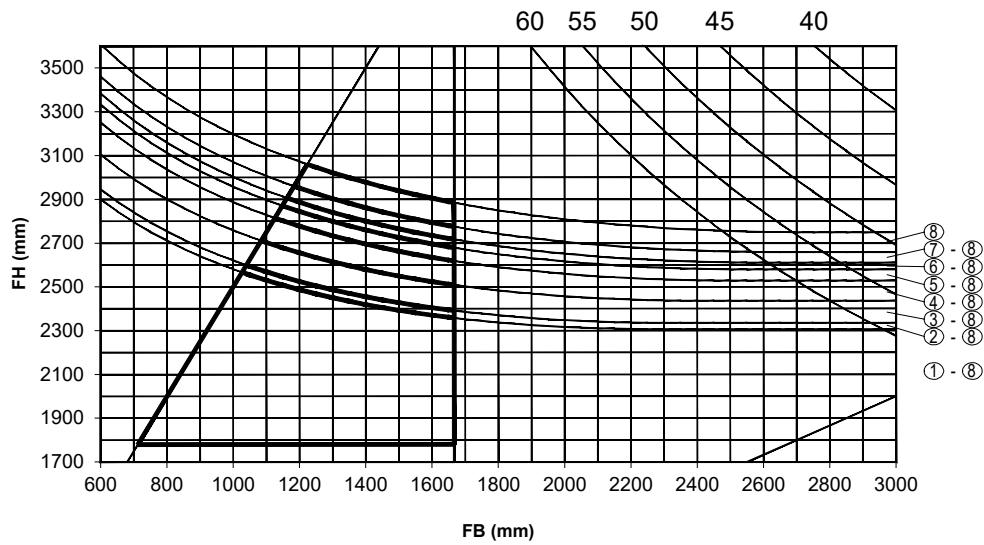

P = 1800Pa  
FG max = 400kg

P = WINDDRUK  
 P = PRESSION DU VENT  
 P = WINDRUCK  
 P = WIND PRESSURE  
 FG = VLEUGELGEWICHT  
 FG = POIDS DU VANTAIL  
 FG = FLÜGELGEWICHT  
 FG = WEIGHT OF THE VENT  
 f = DOORBUIGING  
 f = FLEXION  
 f = DURCHBIEGUNG  
 f = DEFLECTION

schaal - échelle  
 scale - Maßstab  
 1/2

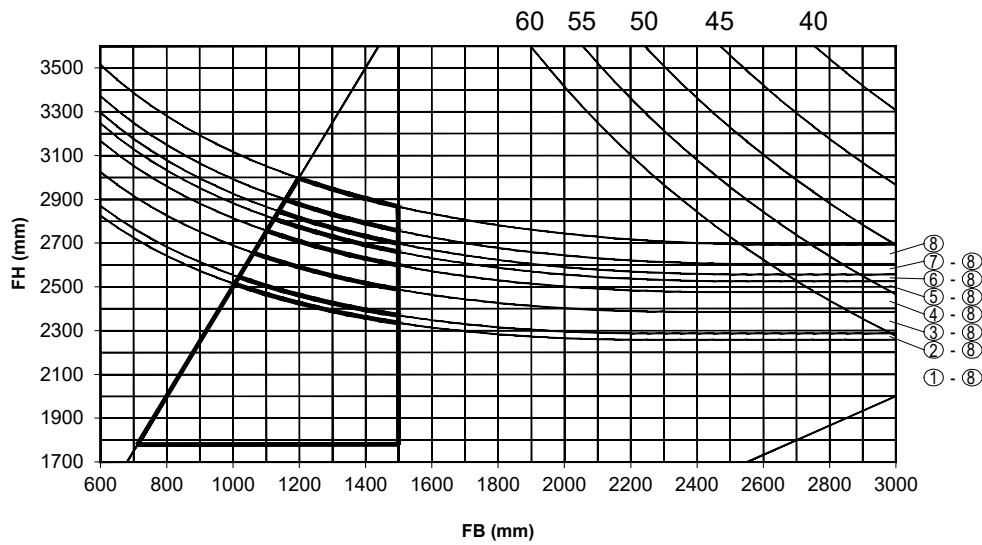

$f_{max} = H / 150$   
max. 12mm

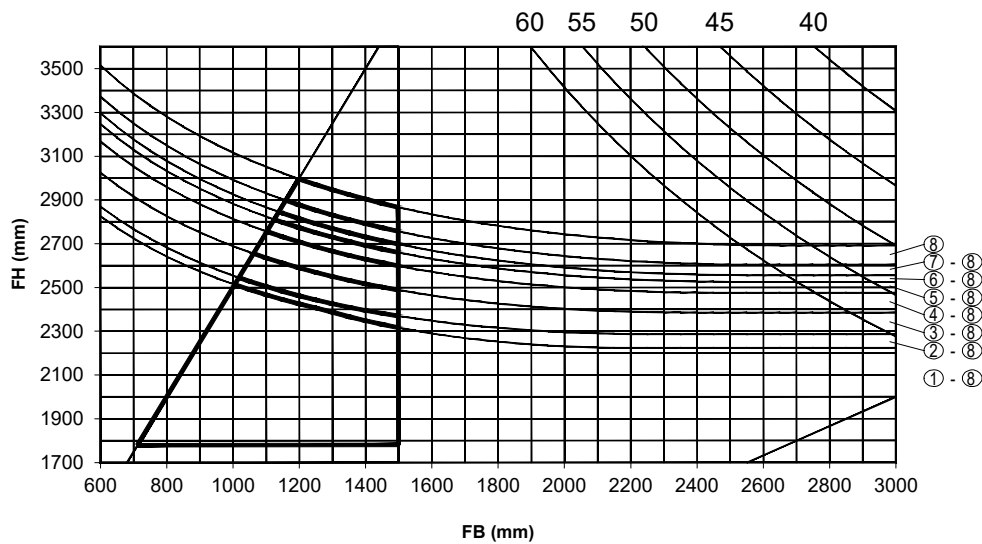

$f_{max} = H / 200$   
max. 12mm

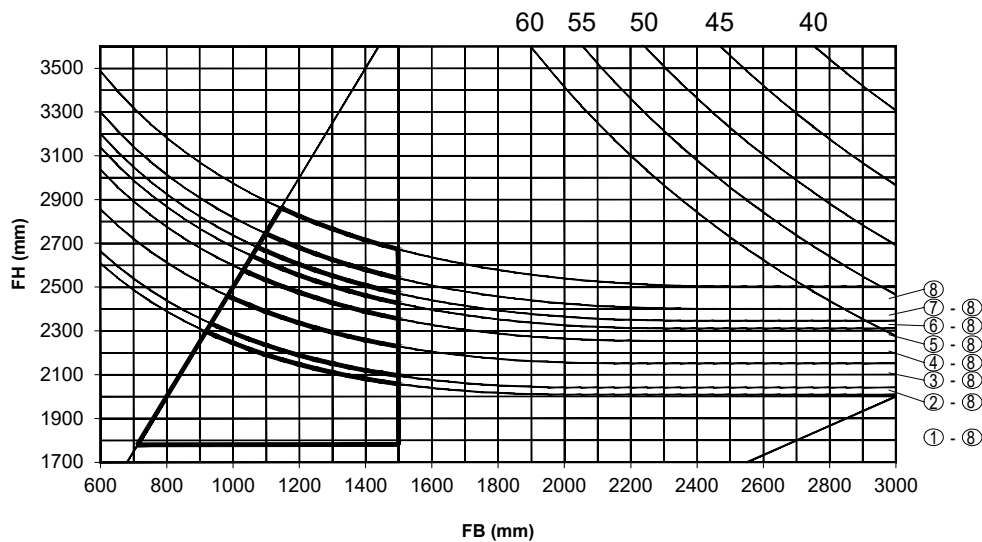

$f_{max} = H / 300$   
max. 12mm

P = 2000Pa  
FG max = 400kg

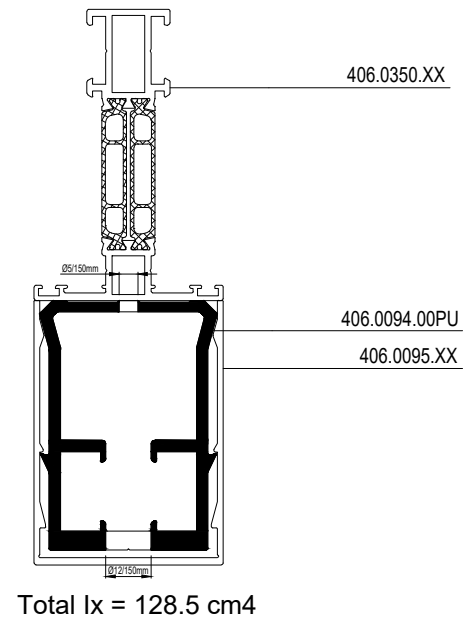
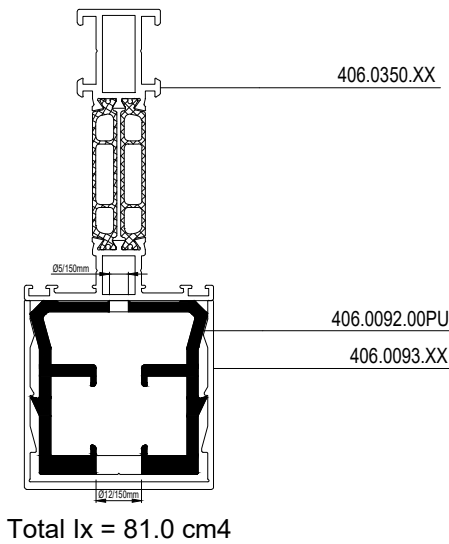
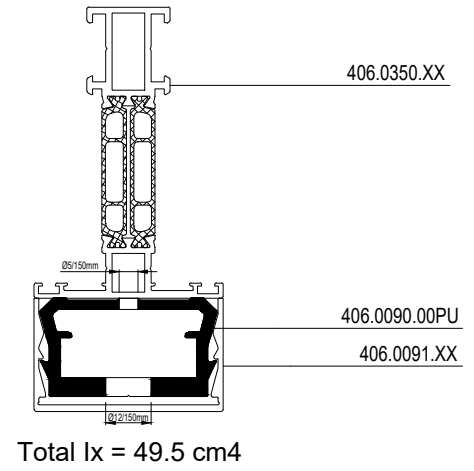
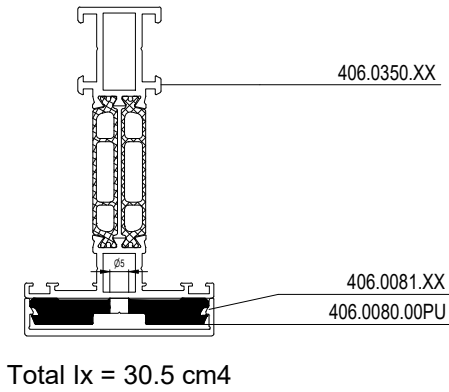

P = WINDDRUK  
 P = PRESSION DU VENT  
 P = WINDRUCK  
 P = WIND PRESSURE  
 FG = VLEUGELGEWICHT  
 FG = POIDS DU VANTAIL  
 FG = FLÜGELGEWICHT  
 FG = WEIGHT OF THE VENT  
 f = DOORBUIGING  
 f = FLEXION  
 f = DURCHBIEGUNG  
 f = DEFLECTION

schaal - échelle  
 scale - Maßstab  
 1/2

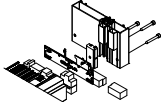

- |   |  |
|---|--|
| <p><b>1.1</b> MAAK ONTWATERINGSGATEN IN HET BODEMPROFIEL<br/>       406.0321.XXPU/406.0312.XXPU/406.0311.XXPU/406.0300.XXPU<br/>       406.0305.XXPU<br/>       FAIRE DES TROUS DRAINAGE DANS LE PROFILE EN BAS<br/>       406.0321.XXPU/406.0312.XXPU/406.0311.XXPU/406.0300.XXPU<br/>       406.0305.XXPU<br/>       MAKE DRAINAGE HOLES IN THE BOTTOM PROFILE<br/>       406.0321.XXPU/406.0312.XXPU/406.0311.XXPU/406.0300.XXPU<br/>       406.0305.XXPU<br/>       MACHEN SIE DIE ENTWAESSERUNG LOCHER IN DIE UNTEN PROFIL<br/>       406.0321.XXPU/406.0312.XXPU/406.0311.XXPU/406.0300.XXPU<br/>       406.0305.XXPU</p> <p><b>1.2</b> MAAK ONTWATERINGSGATEN IN DE KUNSTSTOFPROFIELEN<br/>       406.0320.04/406.0322.04/406.0319.04<br/>       FAIRE DES TROUS DRAINAGE DANS LES PROFILES PLASTIC<br/>       406.0320.04/406.0322.04/406.0319.04<br/>       MAKE DRAINAGE HOLES IN THE PLASTIC PROFILES<br/>       406.0320.04/406.0322.04/406.0319.04<br/>       MACHEN SIE DIE ENTWAESSERUNG LOCHER IN DIE PLASTIK PROFILE<br/>       406.0320.04/406.0322.04/406.0319.04</p> <p><b>1.3</b> VOOR MONORAIL BG: MAAK ONTWATERING IN GLASLATTEN<br/>       POUR MONORAIL IP: FAIRE DES DRAINAGE DANS LES<br/>       PARCLOSES<br/>       FOR MONORAIL OG: MAKE DRAINAGE IN GLAZING BEADS<br/>       FUR MONORAIL AV: MACHEN SIE DIE ENTWAESSERUNG IN DIE<br/>       GLASLEISTEN</p> <p><b>1.4</b> VOOR 2-RAIL/3-RAIL: MAAK ONTWATERING IN AFDEKPROFIEL 406.0363.XX/<br/>       406.0369.XX<br/>       POUR 2-RAIL/3-RAIL: FAIRE DES DRAINAGE DANS LE PROFILE DE<br/>       RECOUVREMENT 406.0363.XX/406.0369.XX<br/>       FOR 2-RAIL/3-RAIL: MAKE DRAINAGE IN COVERING PROFILE 406.0363.XX/<br/>       406.0369.XX<br/>       FUR 2-RAIL/3-RAIL: MACHEN SIE DIE ENTWAESSERUNG IN DIE<br/>       ABDECKPROFIL 406.0363.XX/406.0369.XX</p> <p><b>2</b> VOOR MONORAIL: MAAK DE BEWERKINGEN IN HET VASTE CHICANE<br/>       PROFIEL<br/>       POUR MONORAIL: FAIRE DES OPERATIONS DANS LE CHICANE<br/>       FOR MONORAIL: MAKE THE OPERATIONS IN THE FIXED CHICANE<br/>       PROFILE<br/>       FUR MONORAIL: MACHEN SIE DIE BEARBEITUNGEN IN DIE CHICANE<br/>       PROFIL</p> <p><b>3</b> MAAK DE BEWERKINGEN IN DE ZIJPROFIELEN<br/>       406.0325.XX/406.0327.XX/406.0525.XX/406.0527.XX/<br/>       406.0345.XX+406.0346.XX<br/>       FAIRE DES OPERATIONS DANS LES PROFILS LATERAUX<br/>       406.0325.XX/406.0327.XX/406.0525.XX/406.0527.XX/<br/>       406.0345.XX+406.0346.XX<br/>       MAKE THE OPERATIONS IN THE SIDE PROFILES<br/>       406.0325.XX/406.0327.XX/406.0525.XX/406.0527.XX/<br/>       406.0345.XX+406.0346.XX<br/>       MACHEN SIE DIE BEARBEITUNGEN IN DIE SEITENPROFILE<br/>       406.0325.XX/406.0327.XX/406.0525.XX/406.0527.XX/<br/>       406.0345.XX+406.0346.XX</p> | <p><b>4</b> VOOR MONORAIL: PLAATS 406.0370.XX OP HET BODEMPROFIEL<br/>       MET DICHTING 080.9381.04<br/>       POUR MONORAIL: MONTER 406.0370.XX SUR LE PROFILE EN BAS<br/>       AVEC LE JOINT 080.9381.04<br/>       FOR MONORAIL: PLACE 406.0370.XX ON BOTTOM PROFILE<br/>       WITH GASKET 080.9381.04<br/>       FUR MONORAIL: MONTIEREN SIE 406.0370.XX AUF DIE UNTEN PROFIL<br/>       MIT DICHTUNG 080.9381.04</p> <p><b>5</b> PLAATS 406.0320.04 IN HET BODEMPROFIEL/BOVENPROFIEL<br/>       MONTER 406.0320.04 DANS LE PROFIL EN BAS/LE PROFIL SUPERIEUR<br/>       PLACE 406.0320.04 IN THE BOTTOM PROFILE/TOP PROFILE<br/>       MONTIEREN SIE 406.0320.04 IN DIE UNTEN PROFIL/OBEN PROFIL</p> <p><b>6</b> PLAATS AFDICHTING IN HET BODEMPROFIEL EN BRENG DICHTINGSMIDDEL<br/>       AAN<br/>       MONTER FERMETURE DANS LE PROFILE EN BAS ET APPLIQUER DES<br/>       SCELLANT<br/>       PLACE CLOSER IN BOTTOM PROFILE AND APPLY SEALANT<br/>       MONTIEREN SIE ABDICHTUNG IN DIE UNTEN PROFIL UND ZUTREFFEN<br/>       DICHTMITTEL</p> <p><b>7</b> PLAATS BORSTEL 162.8035.04/162.8036.04 IN HET BOVENPROFIEL MET<br/>       SCHROEF 052.5309.-- EN BRENG DICHTINGSMIDDEL AAN<br/>       MONTER BROUSSE 162.8035.04/162.8036.04 DANS LE PROFILE SUPERIEUR<br/>       AVEC VIS 052.5309.-- ET APPLIQUER DES SCELLANT<br/>       PLACE BRUSH 162.8035.04/162.8036.04 IN TOP PROFILE WITH SCREW<br/>       052.5309.-- AND APPLY SEALANT<br/>       MONTIEREN BURSTE 162.8035.04/162.8036.04 IN DIE OBEN PROFIL MIT<br/>       SCHRAUBE 052.5309.-- UND ZUTREFFEN DICHTMITTEL</p> <p><b>8</b> PLAATS VULBLOK 162.9310.04/162.9312.04/162.9335.04 IN HET<br/>       BODEMPROFIEL EN BRENG DICHTINGSMIDDEL AAN<br/>       MONTER PIECE DE REMPLISSAGE 162.9310.04/162.9312.04/162.9335.04<br/>       DANS LE PROFILE EN BASE ET APPLIQUER DES SCELLANT<br/>       PLACE FILLING PIECE 162.9310.04/162.9312.04/162.9335.04 IN THE BOTTOM<br/>       PROFIL AND APPLY SEALANT<br/>       MONTIEREN SIE FUELLBLOCK 162.9310.04/162.9312.04/162.9335.04<br/>       IN DIE UNTEN PROFIL UND ZUTREFFEN DICHTMITTEL</p> <p><b>9</b> SNIJDT AFDICHTING BUITENKADER 080.9724.04/162.8084.04 EN PLAATS OP<br/>       ONDER- EN BOVENPROFIEL<br/>       COUPE FERMETURE DORMANT 080.9724.04/162.8084.04 ET MONTER SUR<br/>       LE PROFILE EN BAS ET EN HAUTE<br/>       CUT CLOSER OUTER FRAME 080.9724.04/162.8084.04 AND PLACE ON<br/>       BOTTOM AND TOP PROFILE<br/>       SCHNEIDEN SIE ABDICHTUNG BLENDRAHMEN 080.9724.04/162.8084.04 UND<br/>       MONTIEREN SIE DAS STUCKEN AUF UNTER AND OBEN PROFILE</p> <p><b>10</b> PLAATS ASA 406.0326.04 IN ZIJPROFIEL 406.0325.XX/406.0525.XX/<br/>       406.0345.XX<br/>       MONTER ASA 406.0326.04 DANS LE PROFILE DE COTE 406.0325.XX<br/>       406.0525.XX/406.0345.XX<br/>       PLACE ASA 406.0326.04 IN THE SIDE PROFILE 406.0325.XX/406.0525.XX/<br/>       406.0345.XX<br/>       MONTIEREN SIE 406.0326.04 IN DIE SIETE PROFIL 406.0325.XX/406.0525.XX/<br/>       406.0345.XX</p> |
|---|--|

- 11** PLAATS DE AFDICHTINGEN 162.8081.04/168.8675.04 IN DE ZIJPROFIELEN 406.0325.XX/406.0327.XX/406.0525.XX/406.0527.XX/406.0345.XX EN BRENG DICHTINGSMIDDEL AAN  
MONTER LES FERMETURE 162.8081.04/168.8675.04 DANS LES PROFILS LATERAUX 406.0325.XX/406.0327.XX/406.0525.XX/406.0527.XX/406.0345.XX ET APPLIQUER DES SCELLANT  
PLACE CLOSERS 162.8081.04/168.8675.04 IN THE SIDE PROFILES 406.0325.XX/406.0327.XX/406.0525.XX/406.0527.XX/406.0345.XX AND APPLY SEALANT  
MONTIEREN SIE ABDICHTUNG 162.8081.04/168.8675.04 AUF DIE SEITENPROFILE 406.0325.XX/406.0327.XX/406.0525.XX/406.0527.XX 406.0345.XX UND ZUTREFFEN DICHTMITTEL
- 12** BRENG REYNAPROTECT AAN OP ALLE BEWERKTE OPPERVLAKKEN  
APPLIQUER DE REYNAPROTECT SUR TOUT LES SURFACES TRAITE  
APPLY REYNAPROTECT ON ALL PROCESSED SURFACES  
ZUTREFFEN REYNAPROTECT AUF ALLE ERARBEITET OBERFLACHEN
- 13** VOOR MONORAIL: MONTEER DE VASTE CHICANE  
POUR MONORAIL: ASSEMBLER LE CHICANE FIXE  
FOR MONORAIL: ASSEMBLE THE FIXED CHICANE  
FUR MONORAIL: MONTIEREN SIE DIE FESTE CHICANE
- 14** MONTEER HET FRAME  
ASSEMBLER LE DORMANT  
ASSEMBLE THE OUTER FRAME  
MONTIEREN SIE DIE BLENDRAHMEN
- 15** VOOR MONORAIL: MONTEER HET KUNSTSTOF PROFIEL 406.0341.04PU/406.0331.04PU OP HET CHICANE PROFIEL VOOR DE VASTE CHICANE 406.0335.XX/406.0330.XX  
POUR MONORAIL: MONTER LE PROFIL PLASTIC 406.0341.04PU/406.0331.04PU DANS LE CHICANE POUR LE CHICANE FIXE 406.0335.XX/406.0330.XX  
FOR MONORAIL: ASSEMBLE THE PLASTIC PROFILE 406.0341.04PU/406.0331.04PU TO THE CHICANE PROFILE FOR THE FIXED CHICANE 406.0335.XX/406.0330.XX  
FUR MONORAIL: MONTIEREN SIE DIE PLASTIK PROFILE 406.0341.04PU/406.0331.04PU AUF DIE CHICANE PROFIL FUR DIE FESTE CHICANE 406.0335.XX/406.0330.XX
- 15 B** VOOR MONORAIL BG QXQ: MONTEER HET KUNSTSTOF PROFIEL 406.0351.04PU EN PROFIEL 406.0315.XX OP HET CHICANE PROFIEL VOOR DE VASTE CHICANE 406.0335.XX  
POUR MONORAIL IP QXQ: MONTER LE PROFIL PLASTIC 406.0351.04PU ET PROFIL 406.0315.XX DANS LE CHICANE POUR LE CHICANE FIXE 406.0335.XX  
FOR MONORAIL OG QXQ: ASSEMBLE THE PLASTIC PROFILE 406.0351.04PU AND PROFILE 406.0315.XX TO THE CHICANE PROFILE FOR THE FIXED CHICANE 406.0335.XX  
FUR MONORAIL AV QXQ: MONTIEREN SIE DIE PLASTIK PROFIL 406.0351.04PU UND PROFIL 406.0315.XX AUF DIE CHICANE PROFIL FUR DIE FESTE CHICANE 406.0335.XX
- 16** VOOR MONORAIL: PLAATS DE DICHTINGEN 180.9410.04/180.9412.04  
POUR MONORAIL: MONTER LE JOINTS 180.9410.04/180.9412.04  
FOR MONORAIL: PLACE THE GASKET 180.9410.04/180.9412.04  
FUR MONORAIL: MONTIEREN SIE DIE DICHTUNG 180.9140.04/180.9412.04
- 17** PLAATS DE RAILS IN HET BODEMPROFIEL MET DICHTINGSMIDDEL OF DICHTING 180.9160.04  
MONTER LES RAILS DANS LE PROFILE EN BAS AVEC DE SCELLANT OU JOINT 180.9160.04  
PLACE THE RAILS IN THE BOTTOM PROFILE WITH SEALANT OR GASKET 180.9160.04  
MONTIEREN SIE DIE SCHIENEN IN DIE UNTEN PROFIL MIT DICHTMITTEL ODER DICHTUNG 180.9160.04
- 18** PLAATS PROFIEL 406.0322.04/406.0319.04 IN GOOT  
MONTER PROFIL 406.0322.04/406.0319.04 DANS GOUTTIERE  
PLACE PROFILE 406.0322.04/406.0319.04 IN GUTTER  
MONTIEREN SIE PROFIL 406.0322.04/406.0319.04 IM RINNE
- 19** PLAATS AFDEKPROFIELEN 406.0365.XX/406.0364.XX/406.0369.XX MET DICHTING 080.9381.04, 406.0366.XX/406.0363.XX MET DICHTING 180.9412.04 EN 406.0367.XX  
MONTER PROFILE DE RECOUVREMENT 406.0365.XX/406.0364.XX/406.0369.XX AVEC JOINT 080.9381.04, 406.0366.XX/406.0363.XX AVEC JOINT 180.9412.04 ET 406.0367.XX  
PLACE COVERING PROFILE 406.0365.XX/406.0364.XX/406.0369.XX WITH GASKET 080.9381.04, 406.0366.XX/406.0363.XX WITH GASKET 180.9412.04 AND 406.0367.XX  
MONTIEREN SIE ABDECKPROFIL 406.0365.XX/406.0364.XX/406.0369.XX MIT DICHTUNG 080.9381.04, 406.0366.XX/406.0363.XX MIT DICHTUNG 180.9412.04 UND 406.0367.XX
- 20** PLAATS AFDEKPROFIEL VASTE CHICANE 406.0342.XX/406.0332.XX MET DICHTING 080.9381.04  
MONTER PROFILE DE RECOUVREMENT DE CHICANE 406.0342.XX/406.0332.XX AVEC JOINT 080.9381.04  
PLACE COVERINGPROFILE FIXED CHICANE 406.0342.XX/406.0332.XX WITH GASKET 080.9381.04  
MONTIEREN SIE ABDECKPROFIL FESTE CHICANE 406.0342.XX/406.0332.XX MIT DICHTUNG 080.9381.04
- 21** HI: MONTEER DE ISOLATIE 080.9631.07/087.9853.07/087.9870.07/180.9630.07  
HI: ASSEMBLE D'ISOLATION 080.9631.07/087.9853.07/087.9870.07/180.9630.07  
HI: ASSEMBLE INSULATION 080.9631.07/087.9853.07/087.9870.07/180.9630.07  
HI: MONTIEREN SIE ISOLATION 080.9631.07/087.9853.07/087.9870.07/180.9630.07

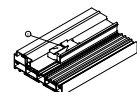
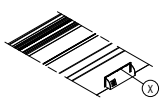
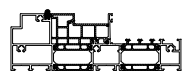
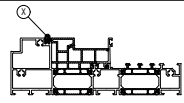
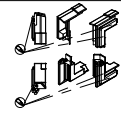
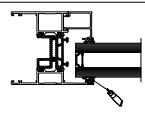
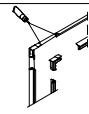
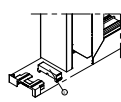
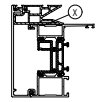
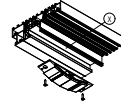
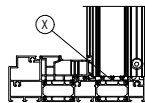
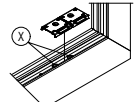
MONORAIL BUITENBEGLAZING MONORAIL INVERSION PARCLOSE MONORAIL OUTSIDE GLAZING MONORAIL AUSSENVERGLASUNG		WATERDICHTHEIDSPRESTATIE PERFORMANCE ETANCHEITE A L'EAU WATER TIGHTNESS PERFORMANCE WASSERDICHTIGKEIT LEISTUNG		
		DICHTINGSMIDDEL / LIJM MASTIC / LA COLLE SEALANT / GLUE DICHTMITTEL / KLEBER	≤600 Pa EN	>600 Pa EN
MONTAGEDETAIL DETAIL DE MONTAGE ASSEMBLY DETAIL MONTAGEDETAIL				
Kader verbindingen Connexions dormant Frame connections Blendrahmen		Ⓡ	✓	✓
Afstandstukken in vleugel 162.9355.04 Pieces d'ecartement dans vaintail 162.9355.04 Distance pieces in vent 162.9355.04 Distanzstuecke 162.9355.04		Ⓢ 084.9107.--	✓	✓
EPDM blok onder chicane Bloc de EPDM sous chicane EPDM block under chicane EPDM block unter chicane		ⓧ	✓	✓
Afdekkap waterafvoersleuven 069.6830.04 Capuchon drainage d'eau 069.6830.04 Weep hole cover 069.6830.04 Abdeckkappe entwaesserung 069.6830.04		ⓧ	✓	✓
Dichting onder rail 180.9160.04 Joint sous rail 180.9160.04 Gasket under rail 180.9160.04 Dichtung unter rail 180.9160.04			✓	×
Dichtingsmiddel onder rail Mastic sous rail Sealant under rail Dichtmittel unter rail		ⓧ		✓
Hoekdichting vleugel 180.9493.04 Joint de coin de vaintail 180.9493.04 Cornergasket vent 180.9493.04 Eckedichtung fluegel 180.9493.04		Ⓢ 084.9107.--	×	✓
Vulcaniseren buitenste glasdichting Vulcaniser joint d'inversion parclose Vulcanise outside glazing gasket Vulkanisieren aussenverglasung dichtung		Ⓢ 084.9108.04	×	✓
Vulcaniseren hoekdichting vleugel 180.9493.04 Vulcaniser joint de coin de vaintail 180.9493.04 Vulcanise cornergasket vent 180.9493.04 Vulkanisieren eckedichtung fluegel 180.9493.04		Ⓢ 084.9108.04	×	✓
Dichtingsmiddel chicane eindstukken Mastic chicane piece finales Sealant chicane endpieces Dichtmittel chicane endkappen		ⓧ	×	✓
Dichtingsmiddel onder ABS chicane Mastic sous chicane ABS Sealant under ABS chicane Dichtmittel unter ABS chicane		ⓧ	×	✓
Borstel boven chicane 162.8035.04 Brosse au-dessus de la chicane 162.8035.04 Brush piece above chicane 162.8035.04 Bürste über chicane 162.0835.04		ⓧ	×	✓
Dichtingsmiddel onder T-verbindingen Mastic sous connexion de T Sealant under T-connections Dichtmittel unter T-Verbindung		ⓧ	×	✓
Glassteun wielen 162.7990.04 Support cale de vitrage de galets 162.7990.04 Glass support wheels 162.7990.04 Glasauflagerprofil laufrad 162.7990.04		ⓧ	×	✓



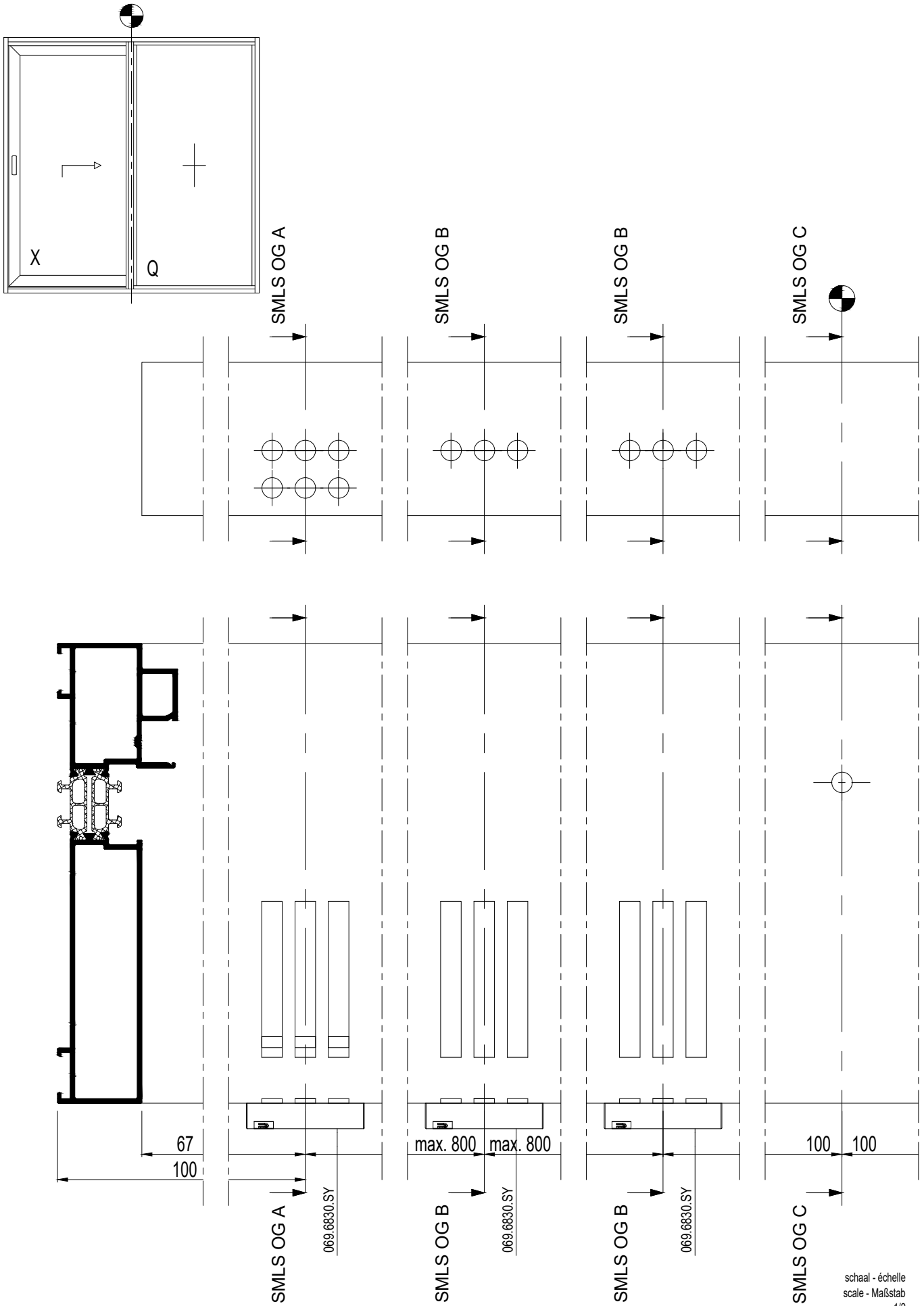

schaal - échelle  
 scale - Maßstab  
 1/2

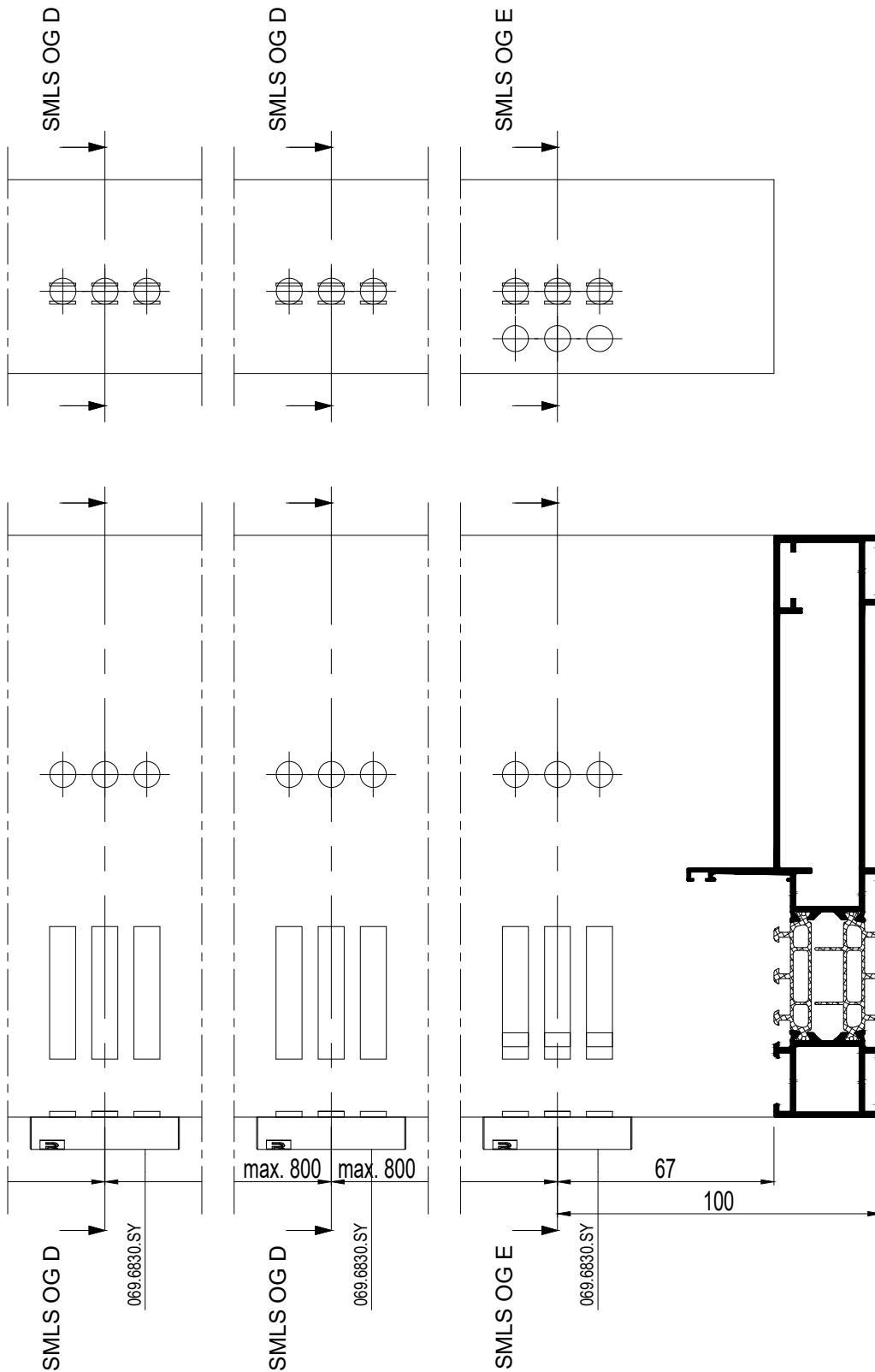

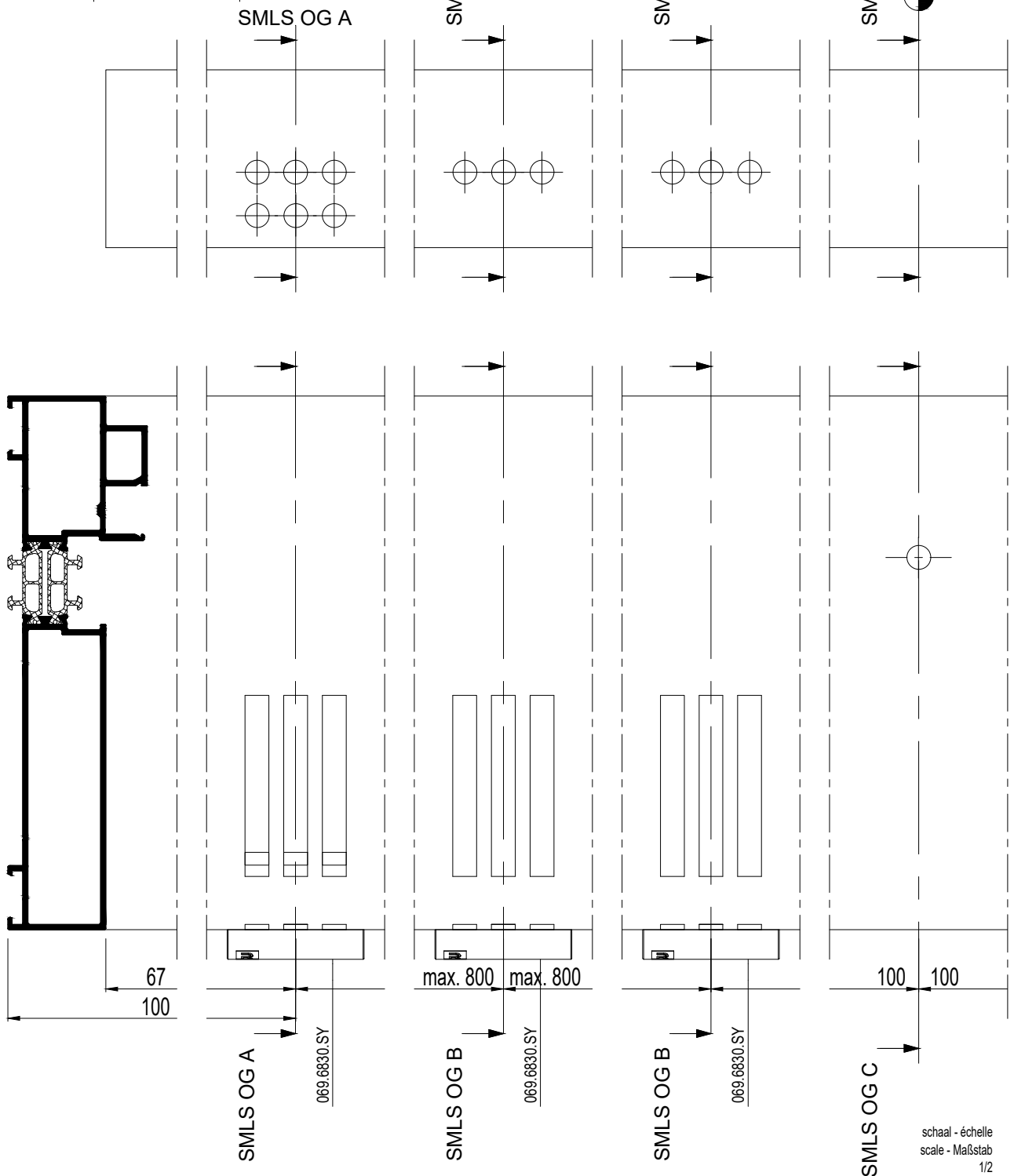
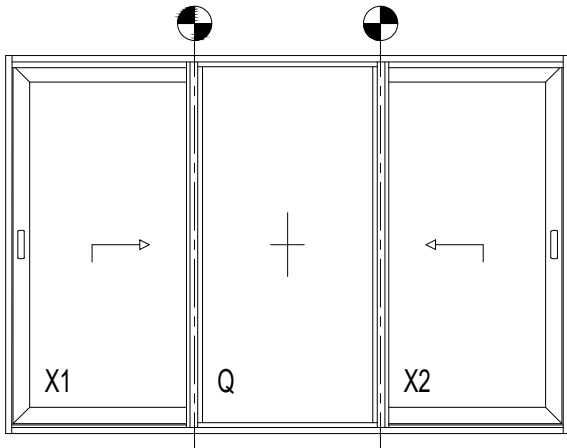

schaal - échelle  
 scale - Maßstab  
 1/2

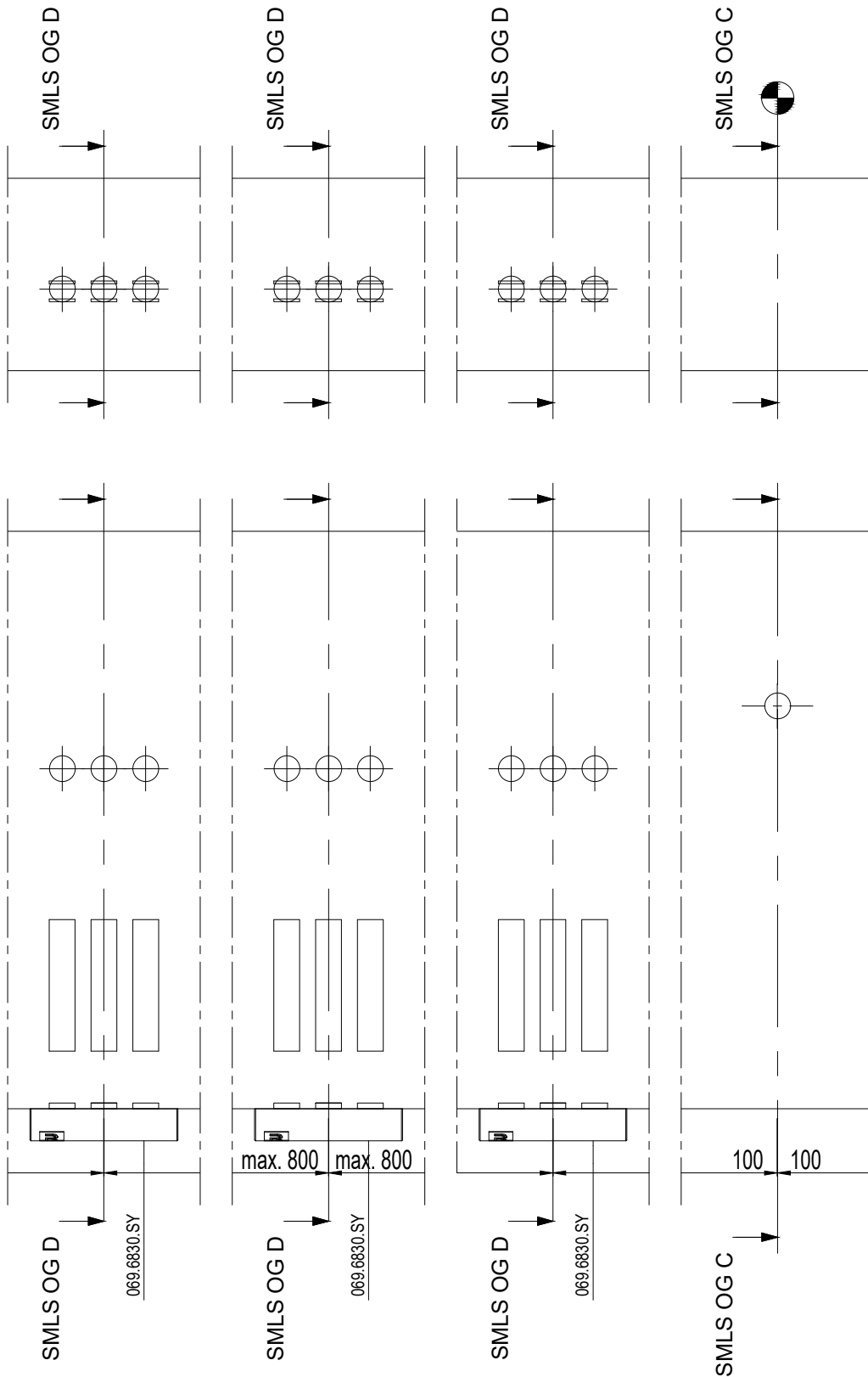

F

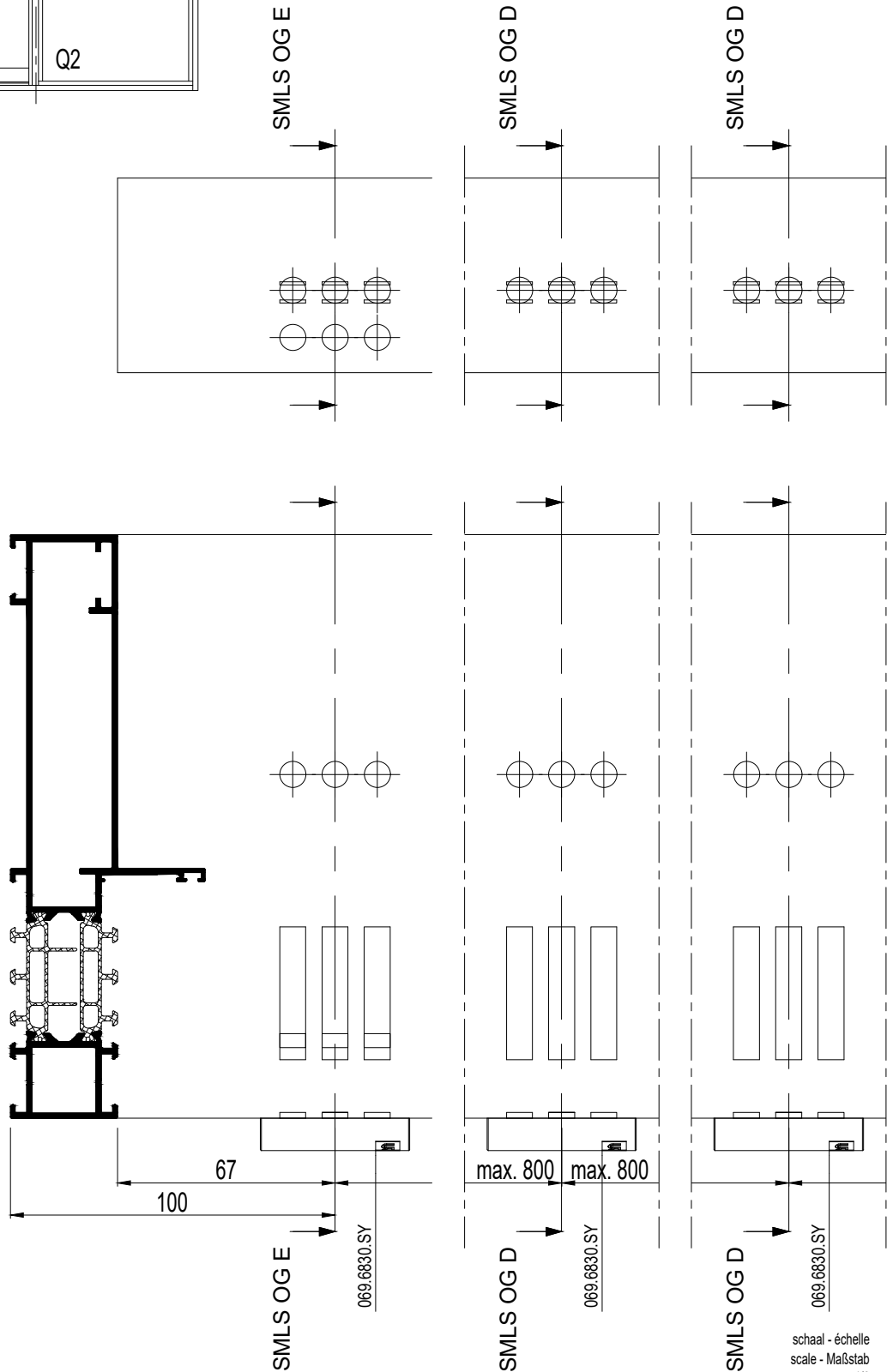
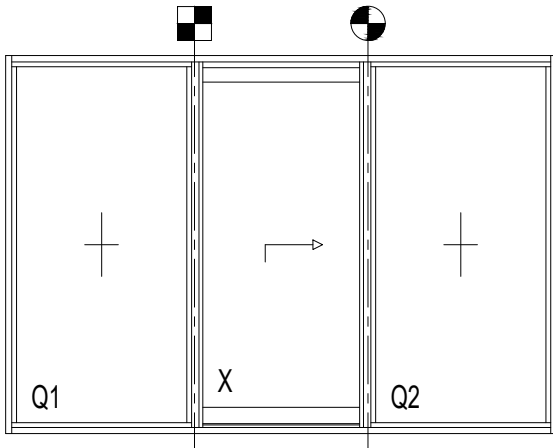

schaal - échelle  
 scale - Maßstab  
 1/2



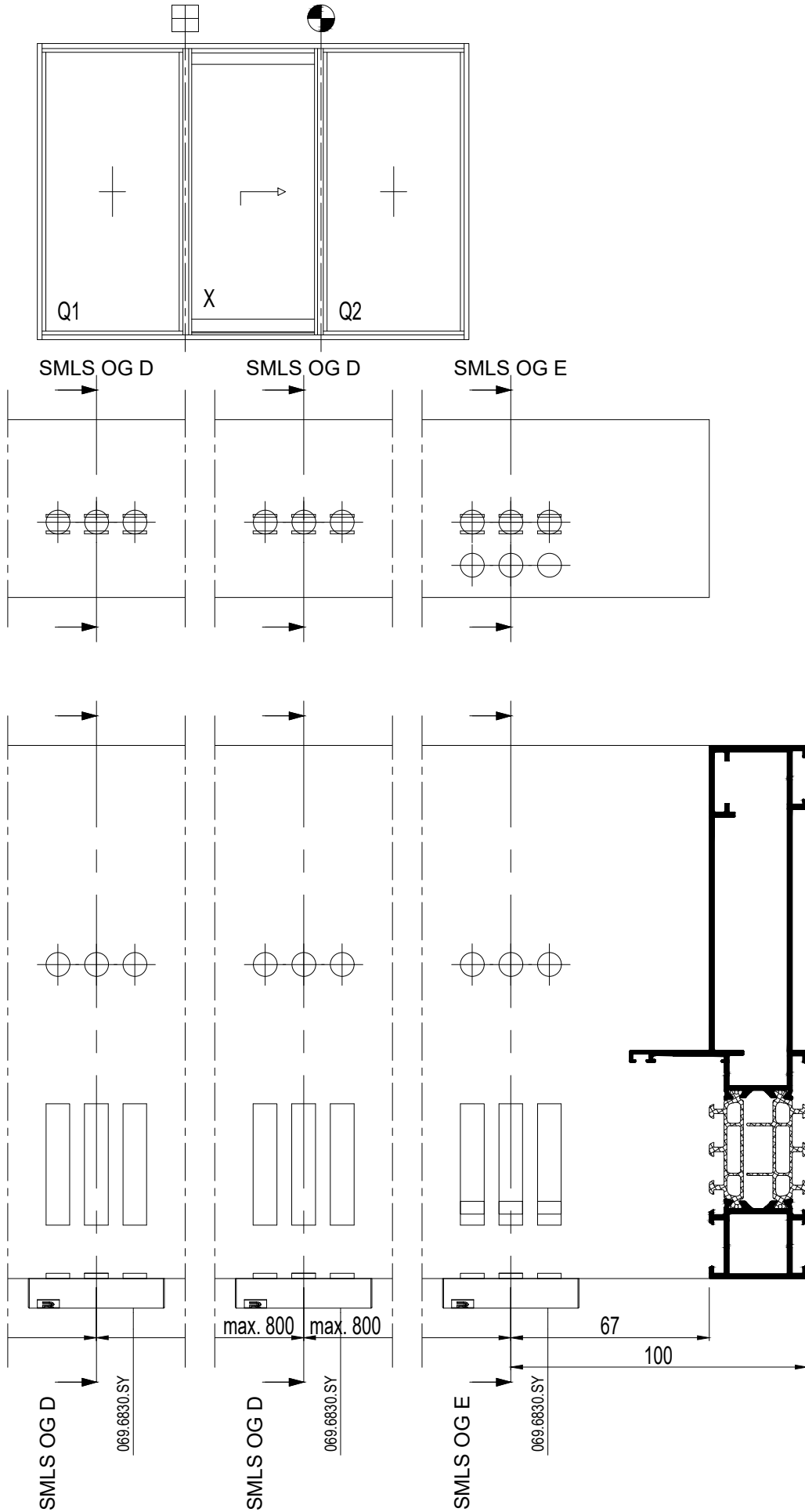



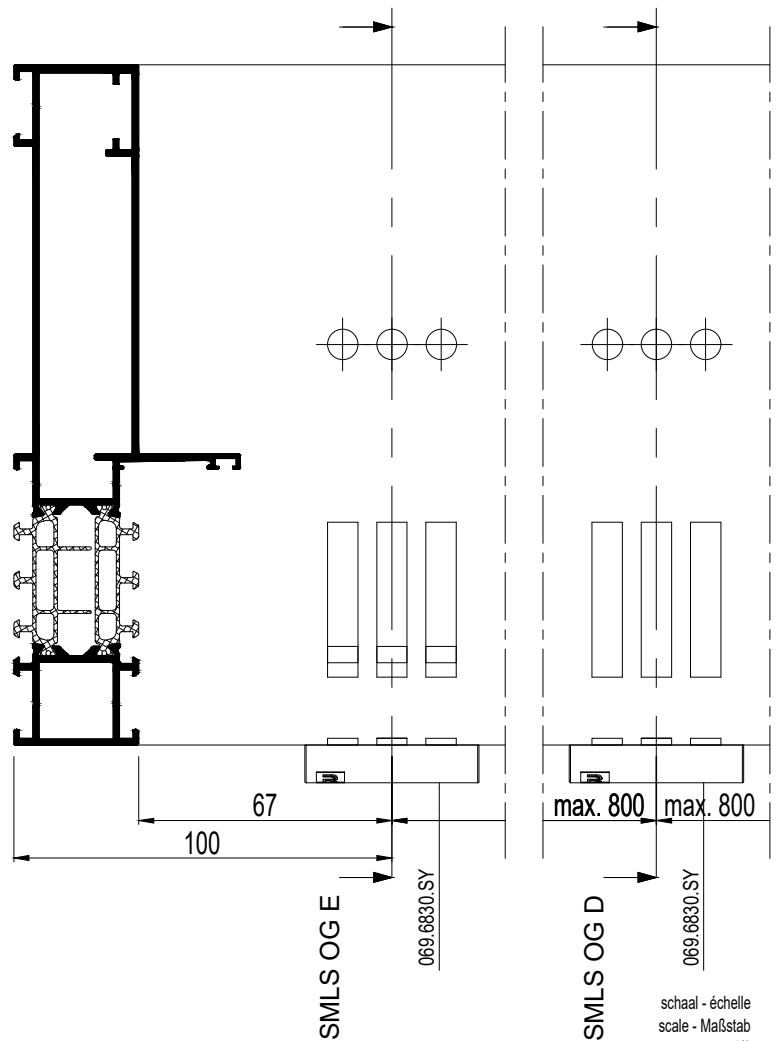
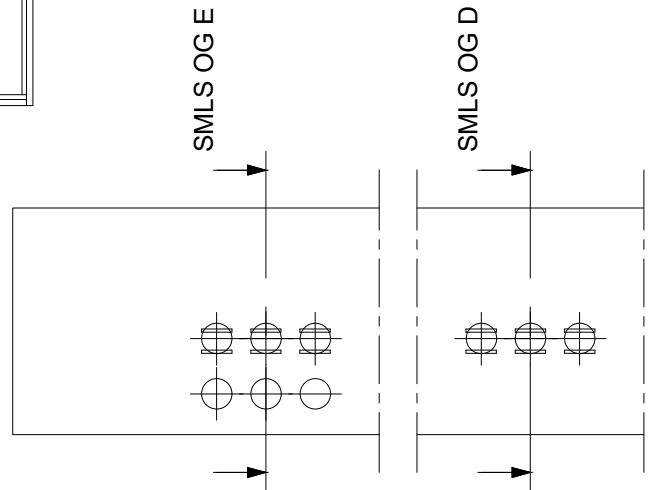
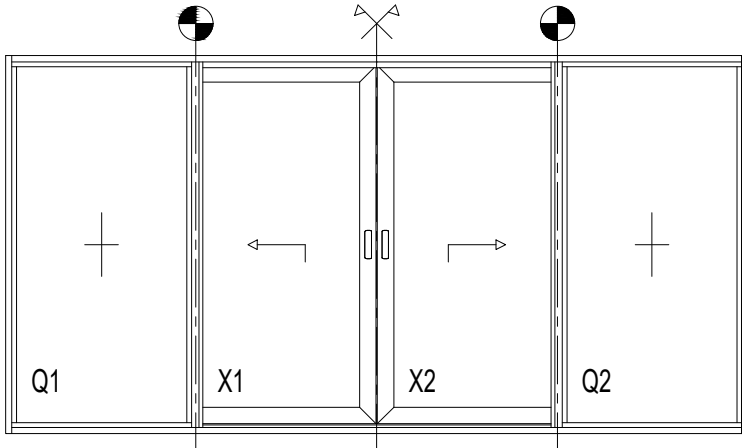

schaal - échelle  
 scale - Maßstab  
 1/2

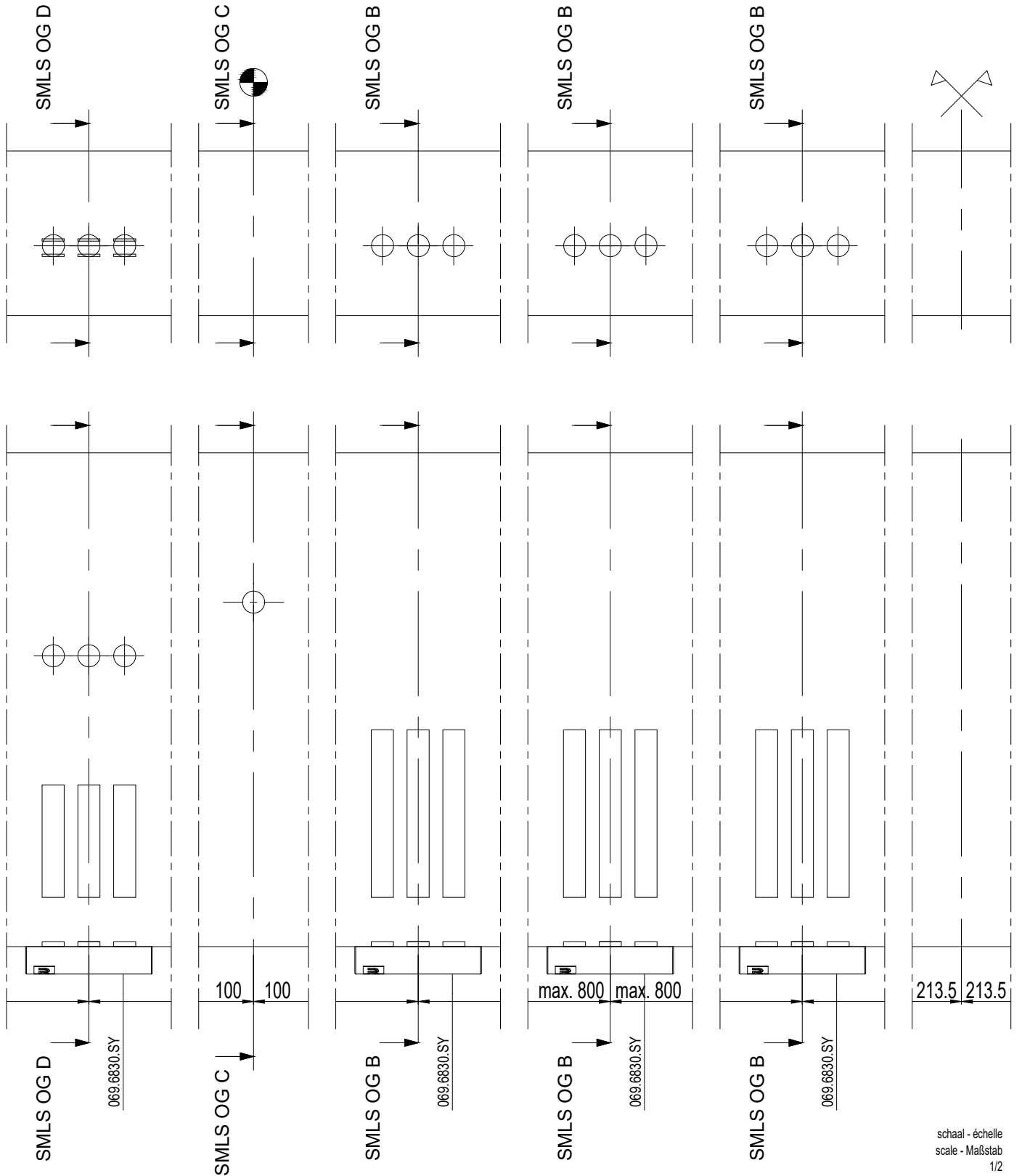

MasterPatio - Masterline 8  D3007352/D3007355

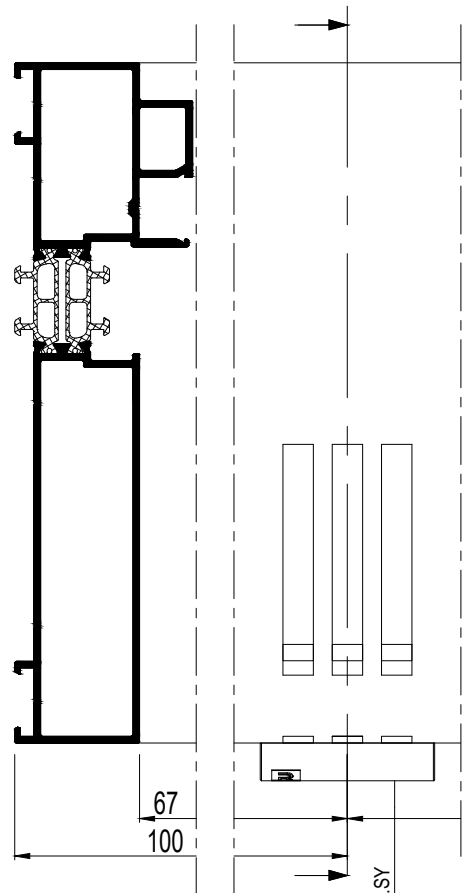
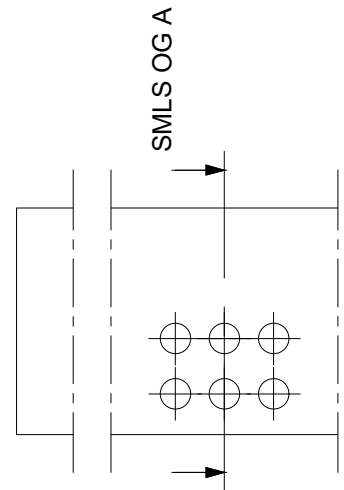
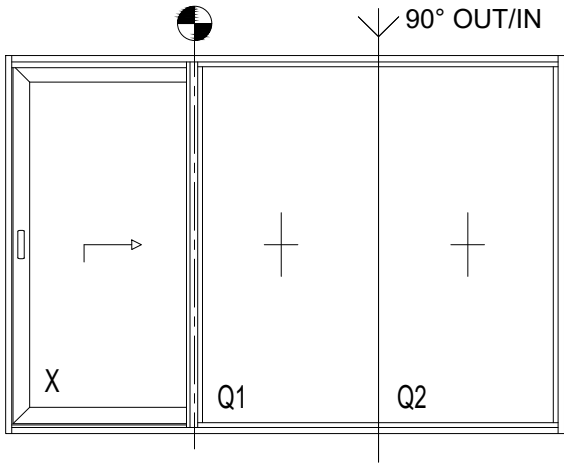

schaal - échelle  
 scale - Maßstab  
 1/2

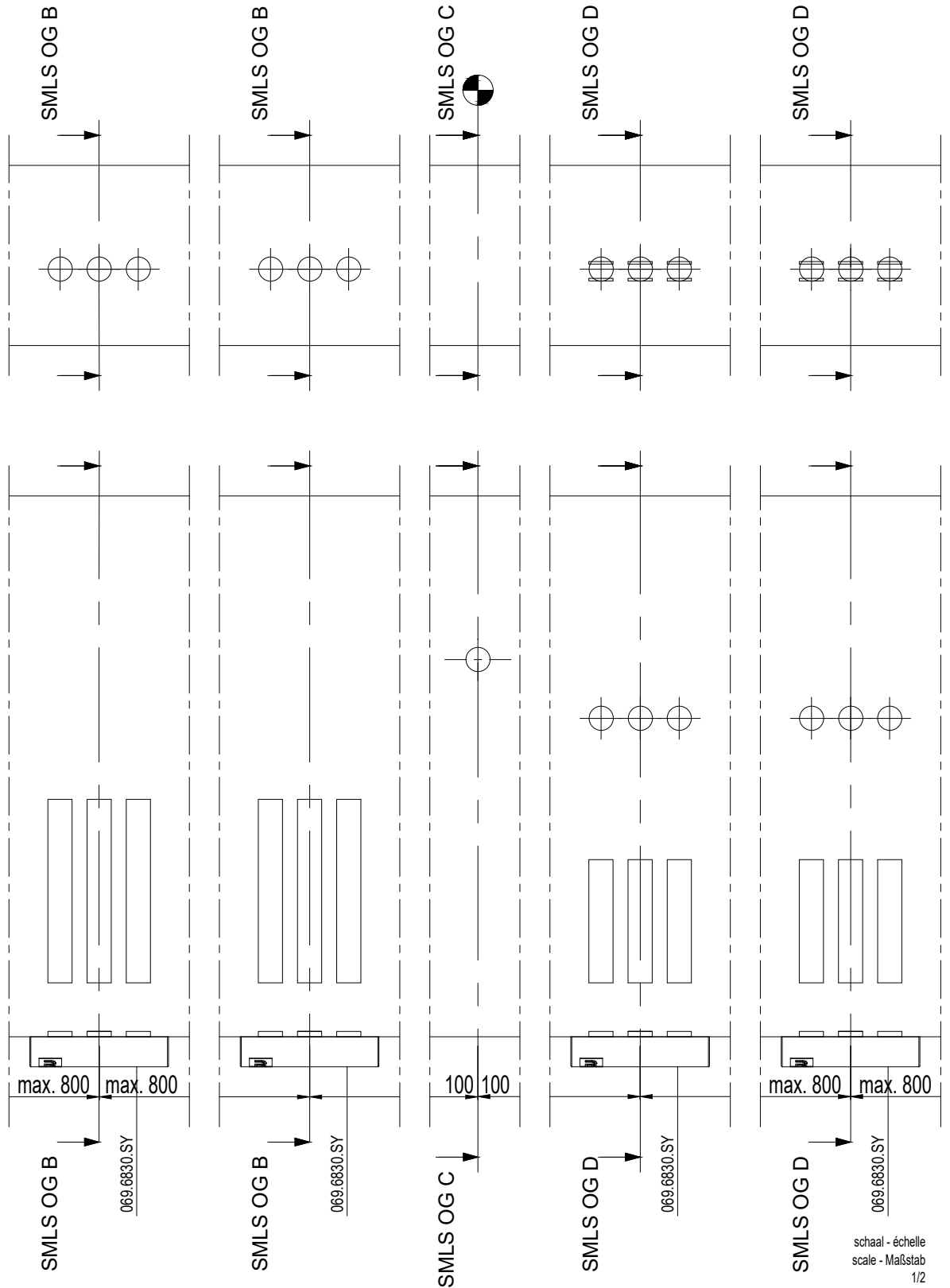

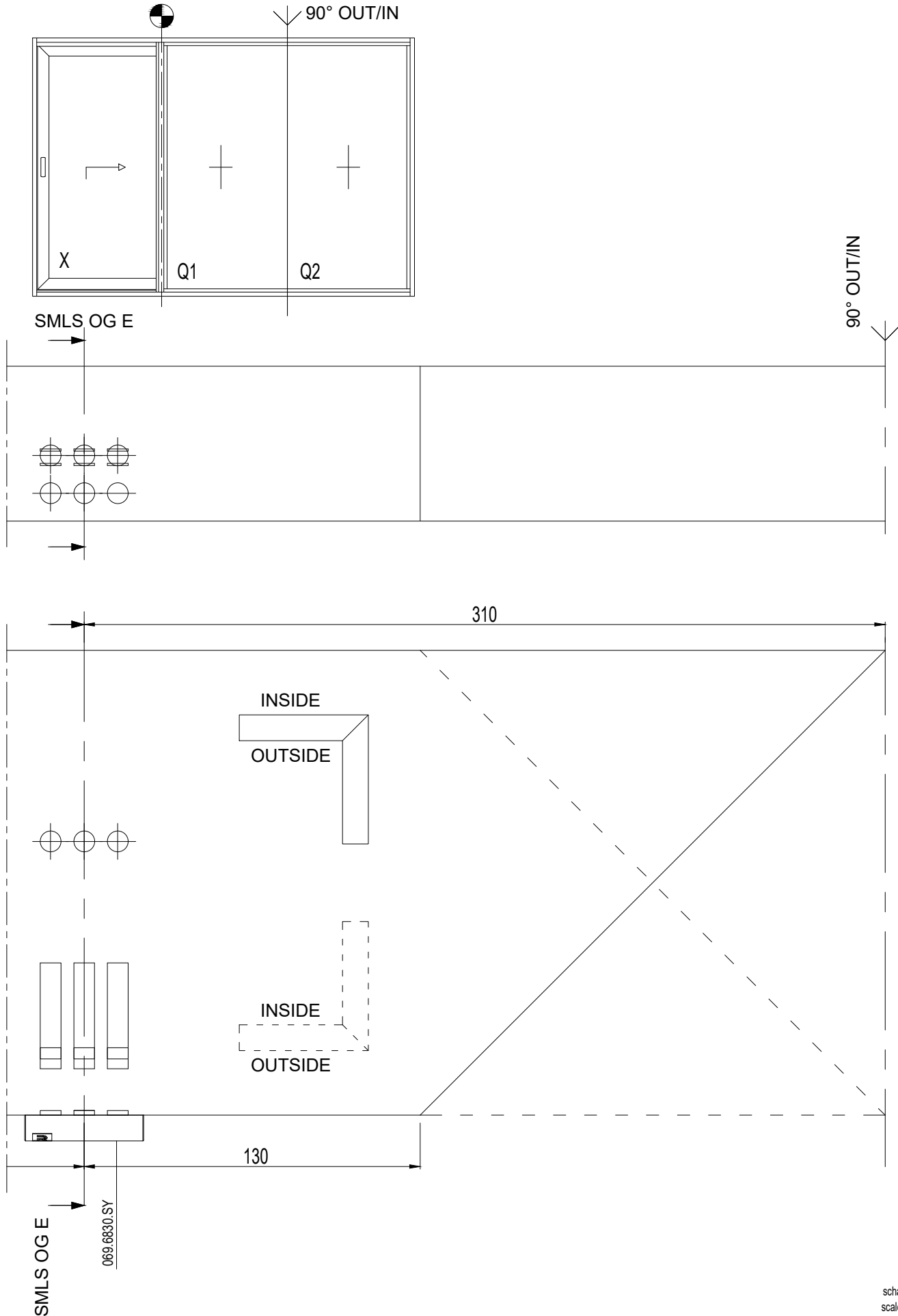



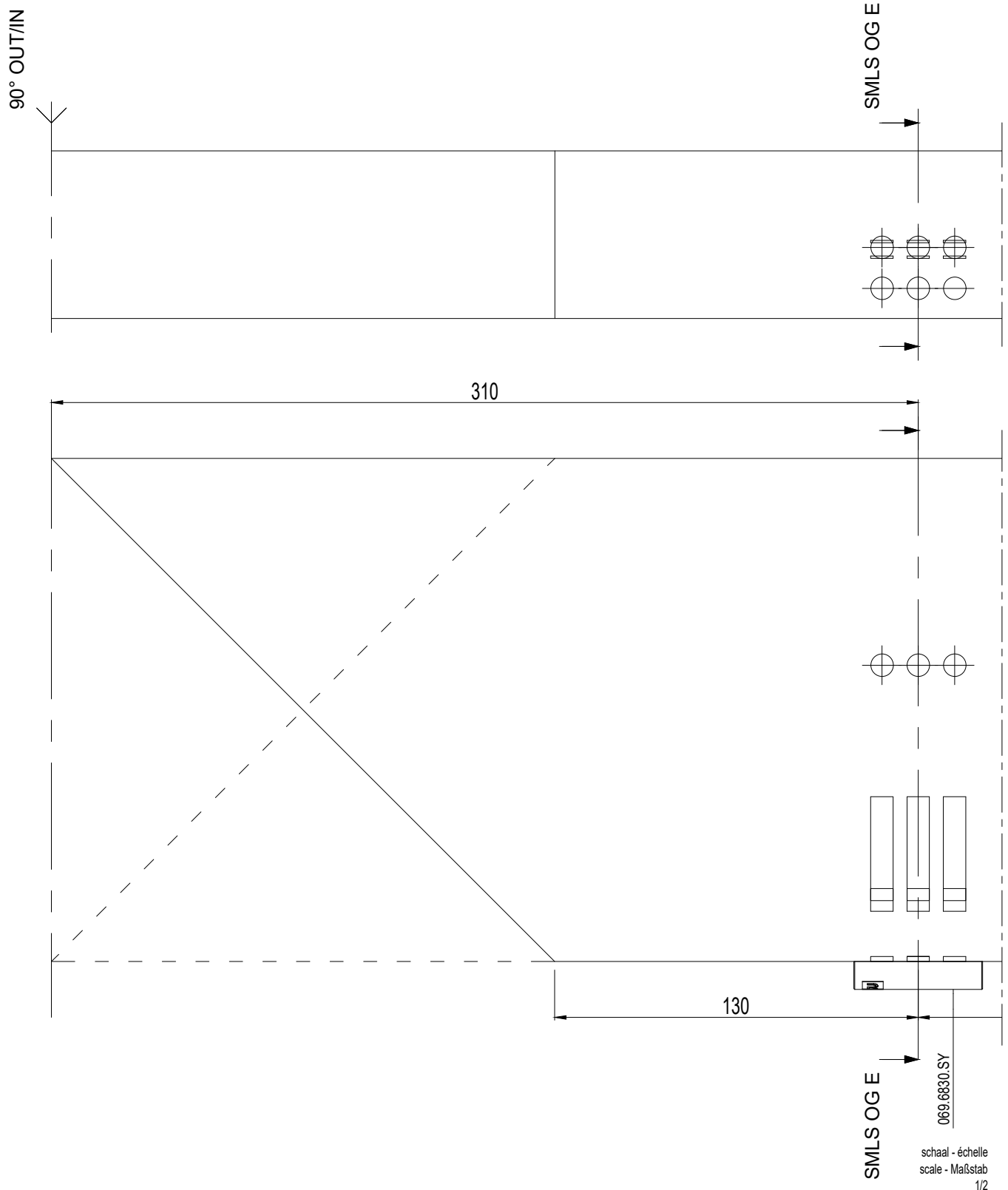

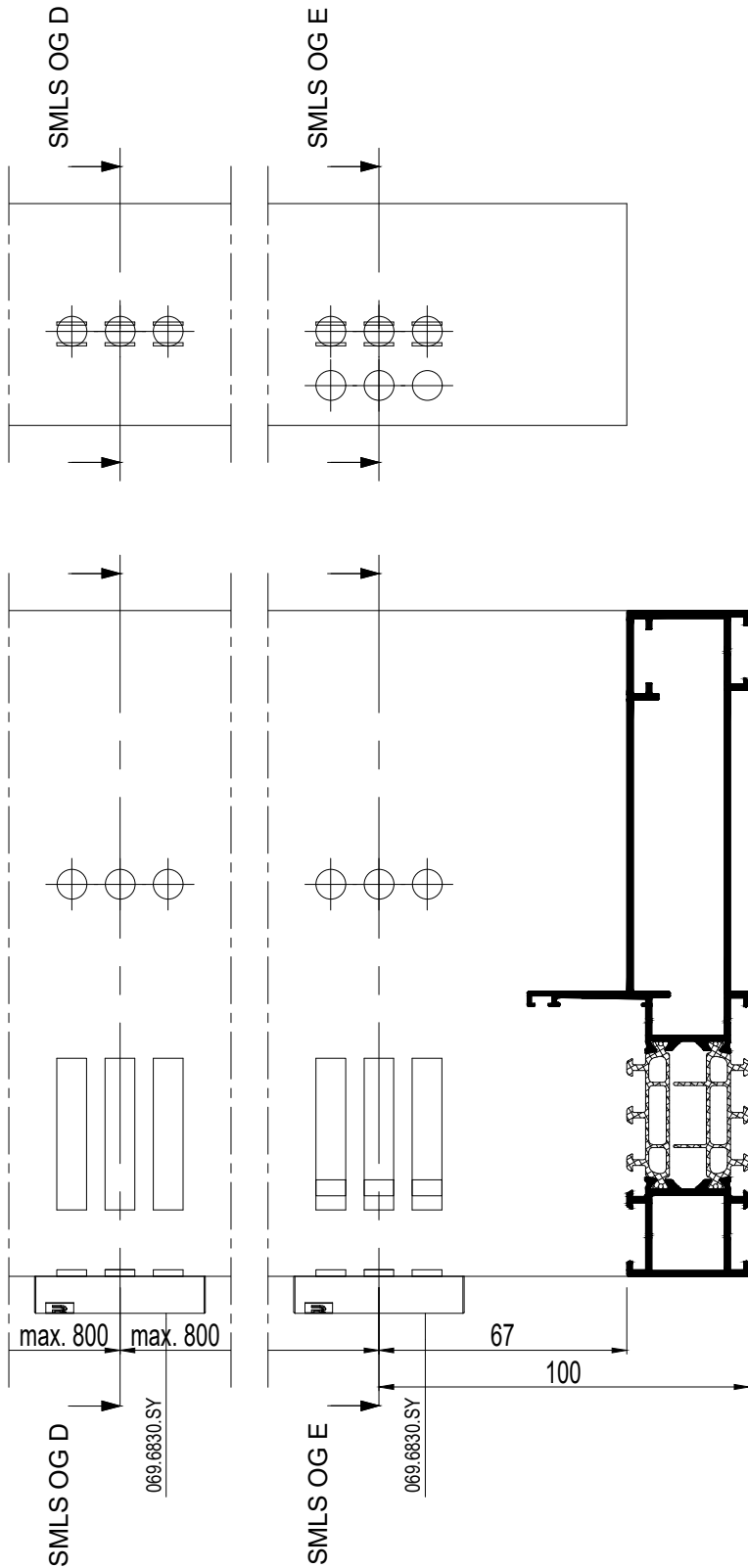

F

MasterPatio - Masterline 8 D3007352/D3007355

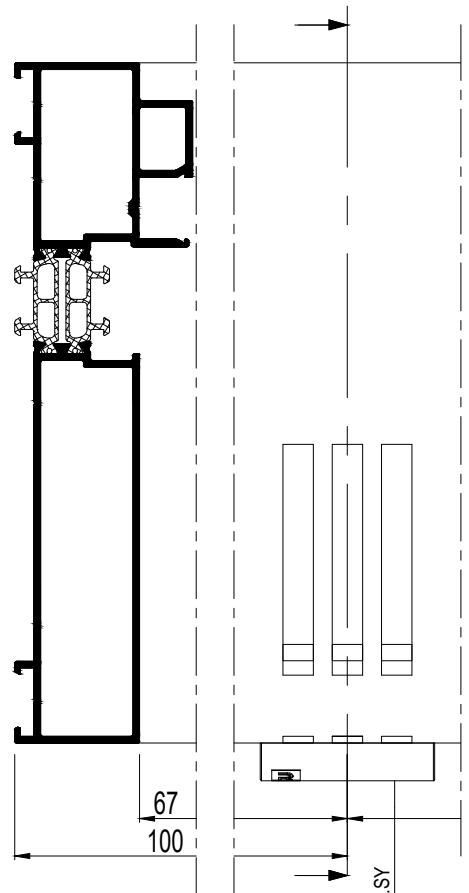
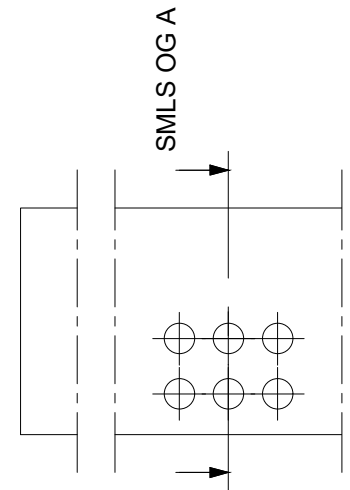
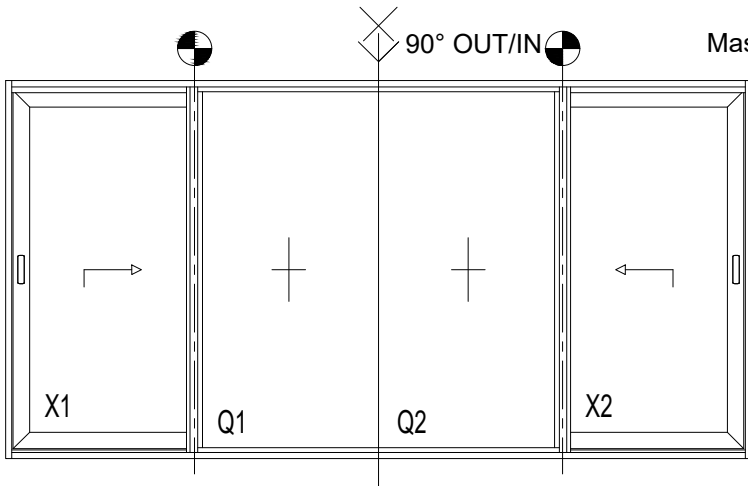

SMLS OGA

069.6830.SY

schaal - échelle  
 scale - Maßstab  
 1/2

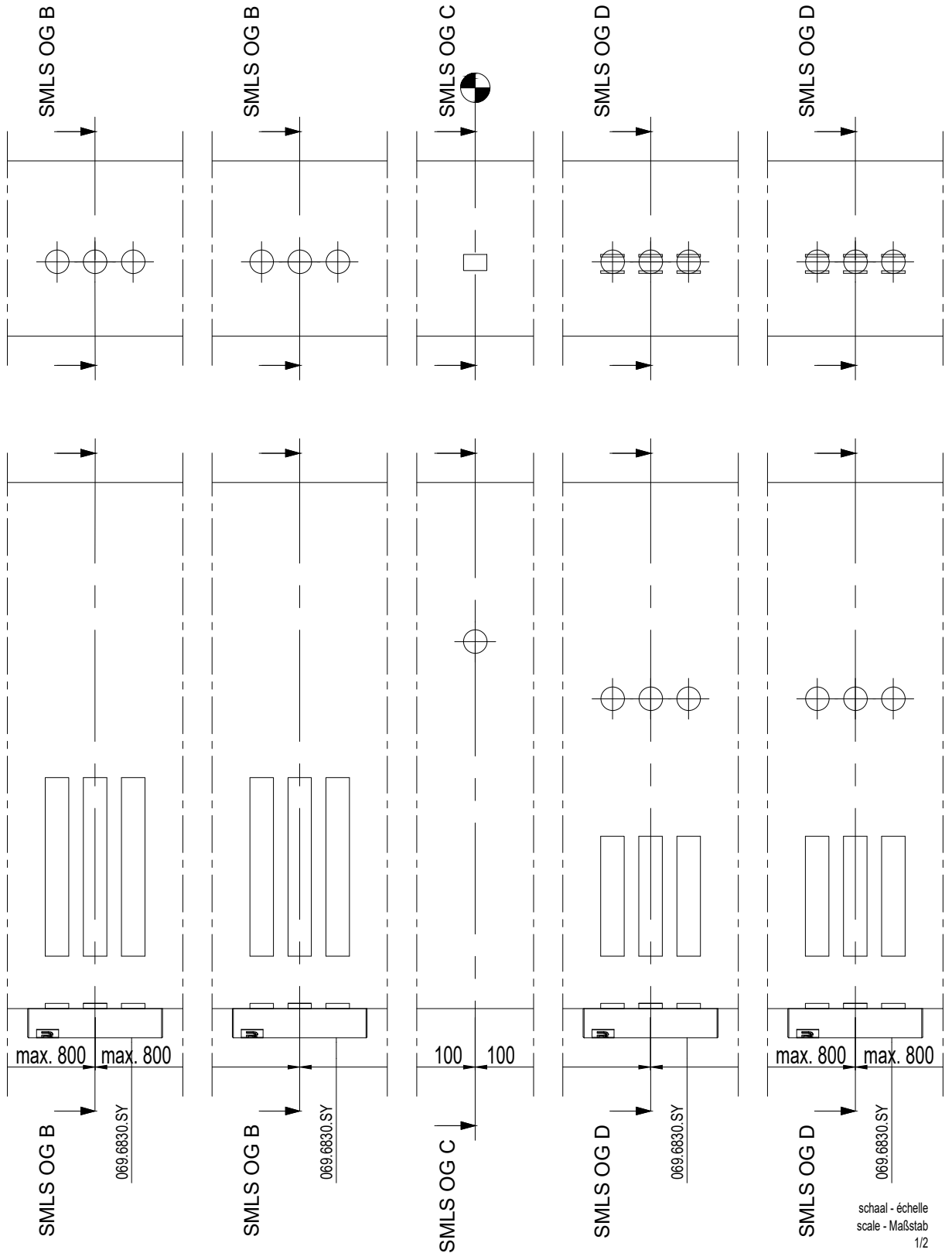

schaal - échelle  
 scale - Maßstab  
 1/2

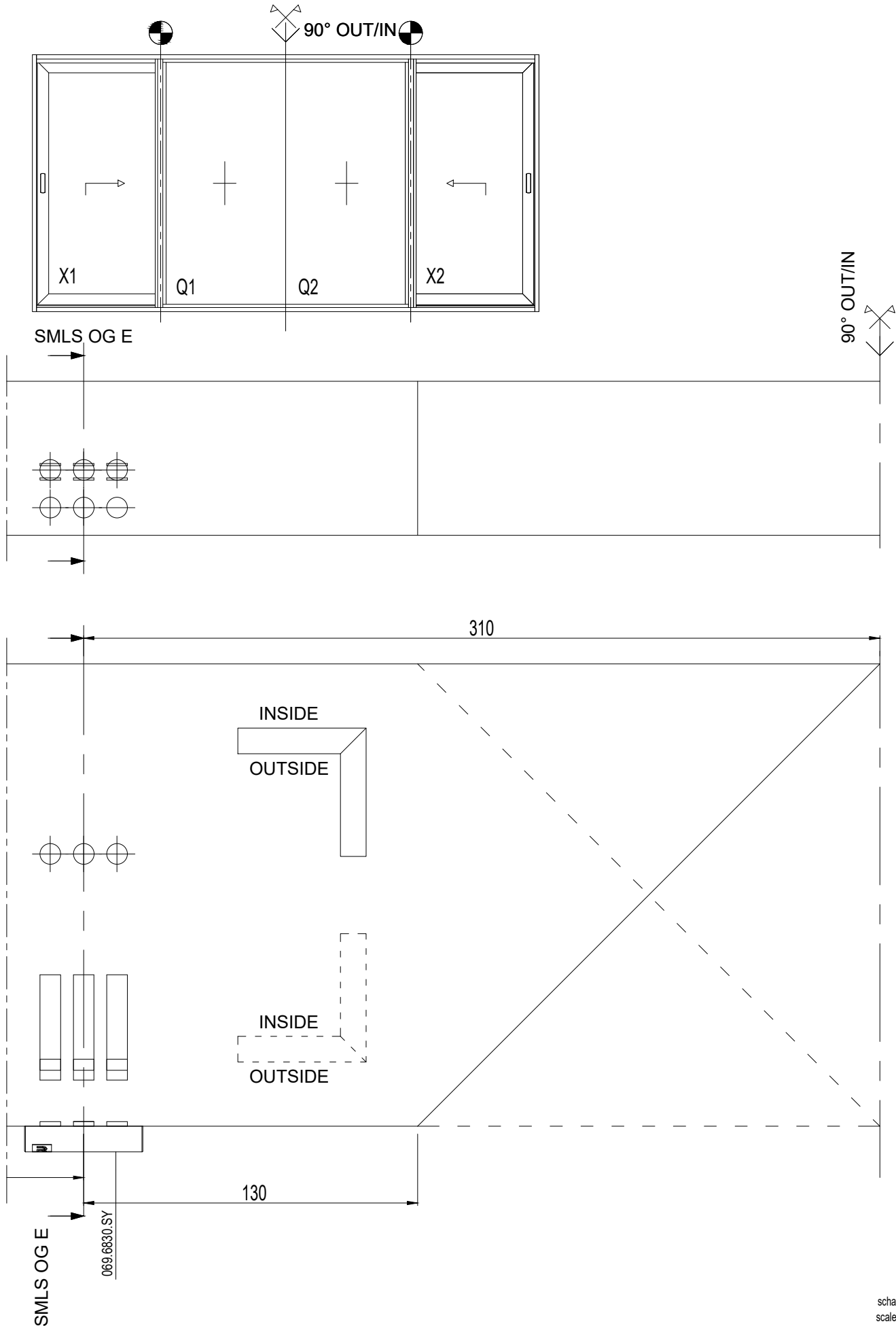

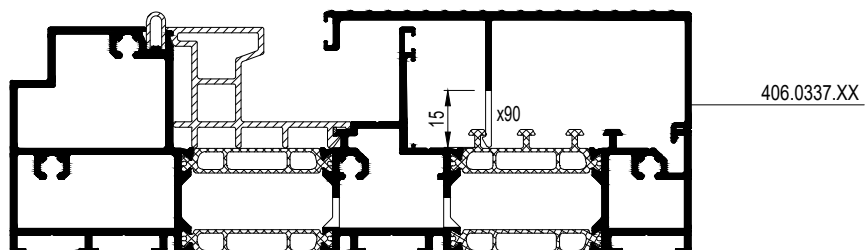
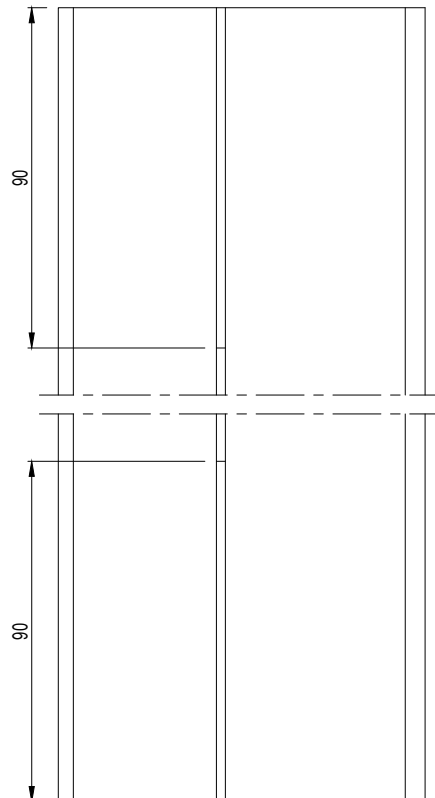
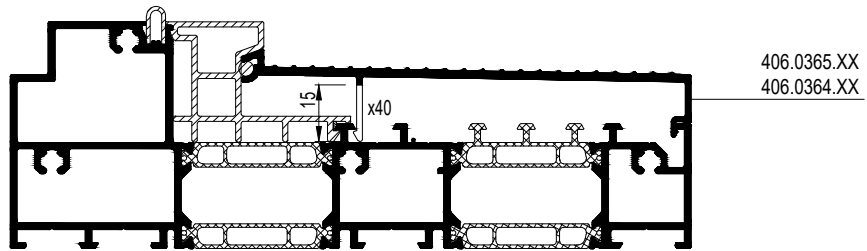
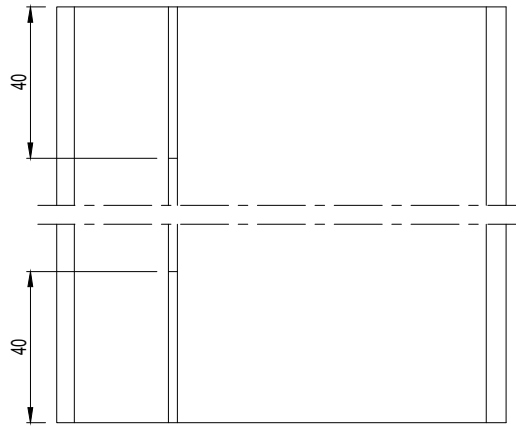

schaal - échelle  
scale - Maßstab  
1/2

1.1 1.2 1.3

MANUEEL  
 MANUEL  
 MANUAL  
 MANUELL

### SMLS OG A

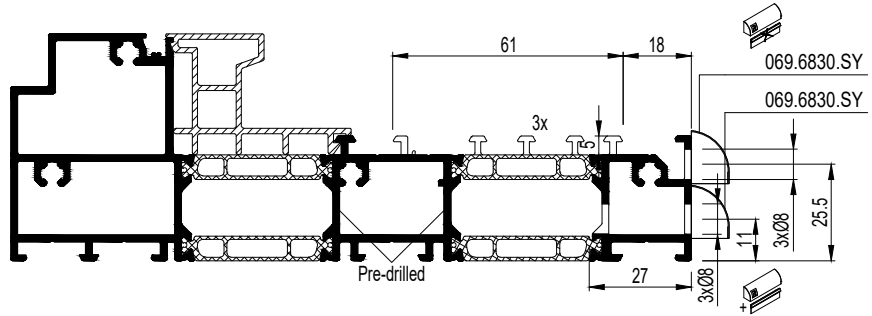

### SMLS OG B

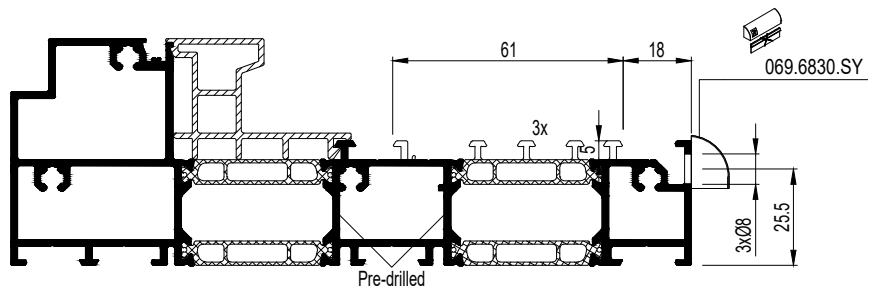

### SMLS OG C

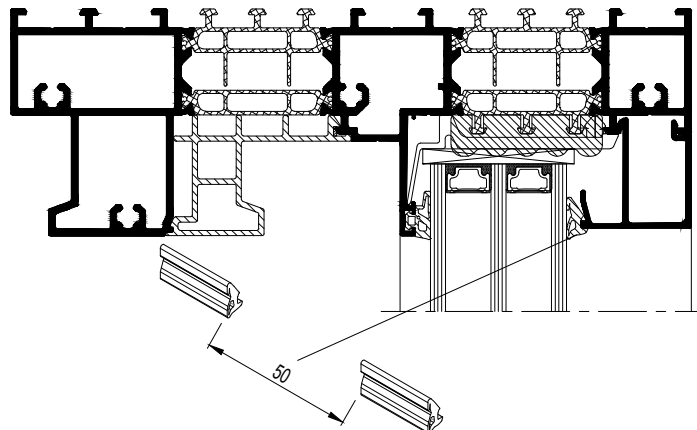
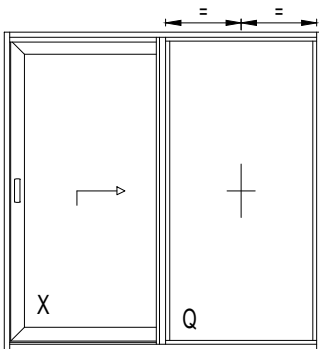
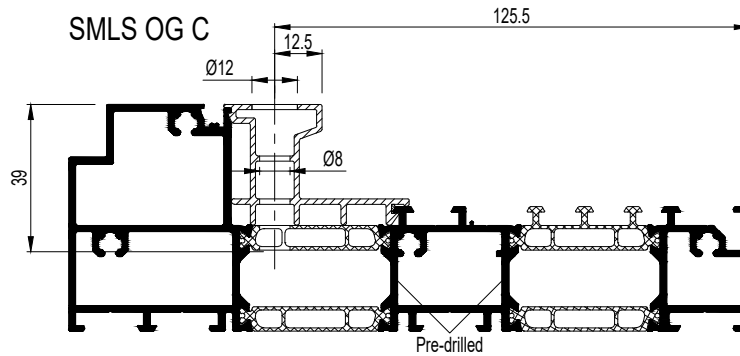

DECOMPRESSIE VAST RAAM  
 DECOMPRESSION CHASSIS FIXE  
 DECOMPRESSION FIXED WINDOW  
 DEKOMPRESSION FESTVERGLASUNG



MONTAGEVOLGORDE  
 L'ORDRE DE MONTAGE  
 THE ORDER OF ASSEMBLY  
 MONTAGEREIHENFOLGE

1 2 3 .

schaal - échelle  
 scale - Maßstab  
 1/2

### SMLS OG D

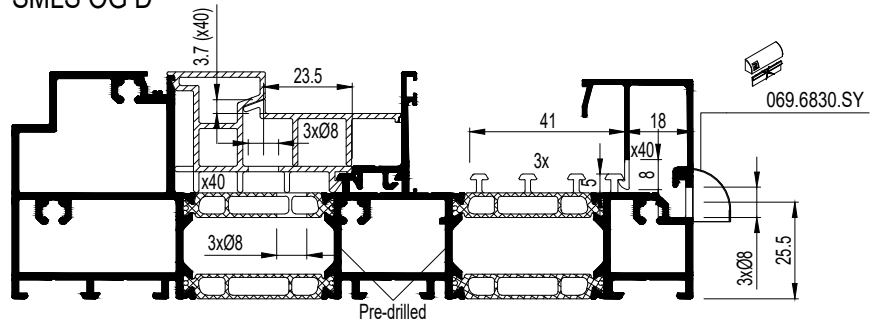

### SMLS OG E

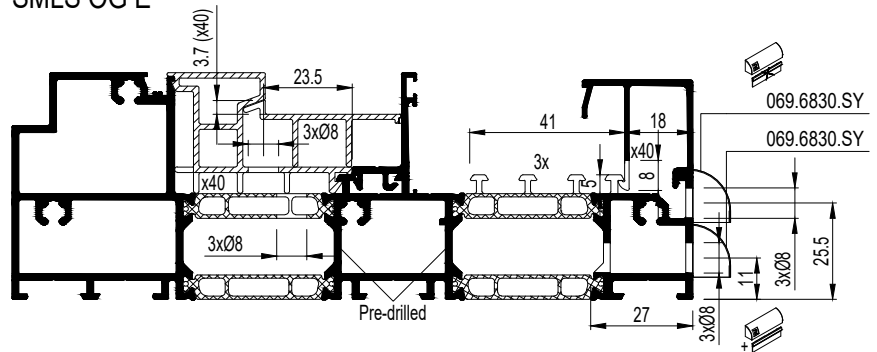

	197.F100.00	406.0320.04	406.0322.04
	097.0839.00	406.0321.XXPU	

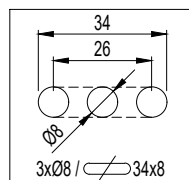

schaal - échelle  
 scale - Maßstab  
 1/2

1.1 1.2 1.3

CNC

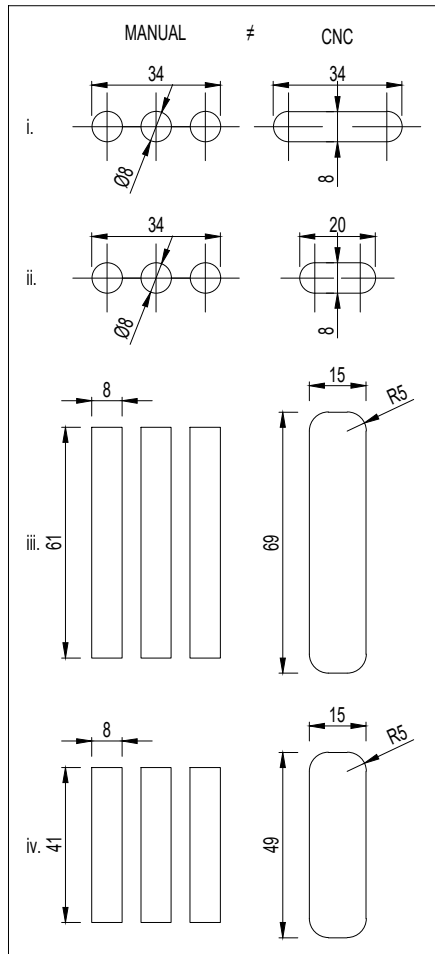

## SMLS OG A

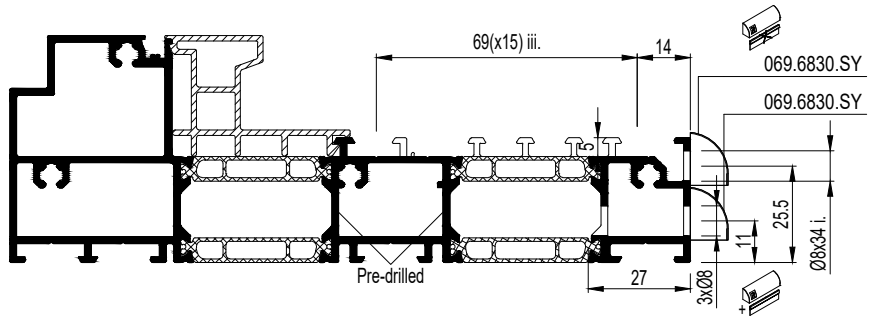

## SMLS OG B

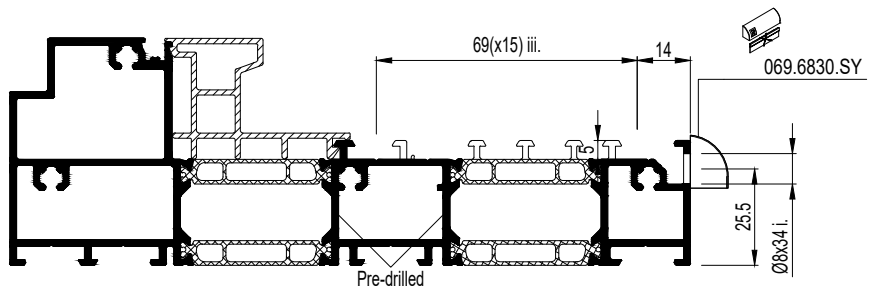

## SMLS OG C

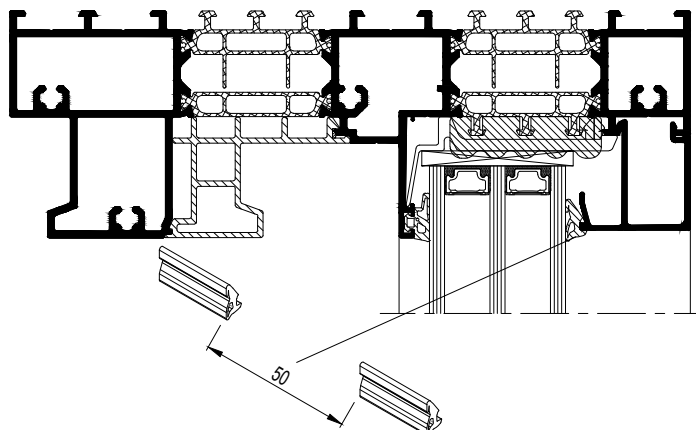
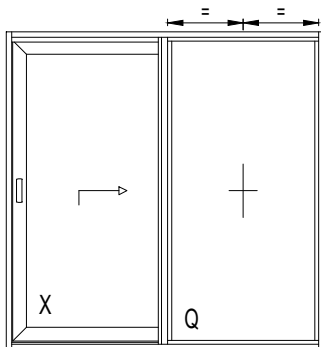
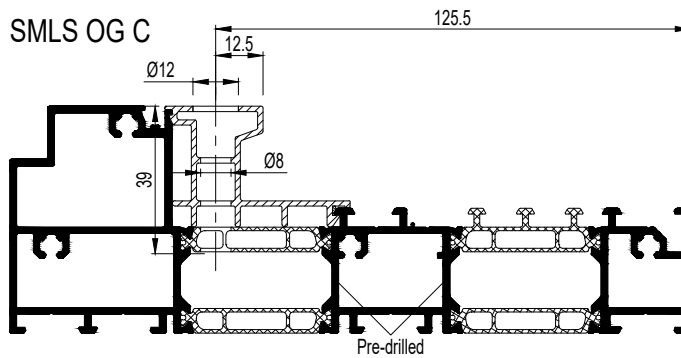

DECOMPRESSIE VAST RAAM  
 DECOMPRESSION CHASSIS FIXE  
 DECOMPRESSION FIXED WINDOW  
 DEKOMPRESSION FESTVERGLASUNG

MONTAGEVOLGORDE  
 L'ORDRE DE MONTAGE  
 THE ORDER OF ASSEMBLY  
 MONTAGEREIHENFOLGE

1 2 3 .

schaal - échelle  
 scale - Maßstab  
 1/2



SMLS OG D

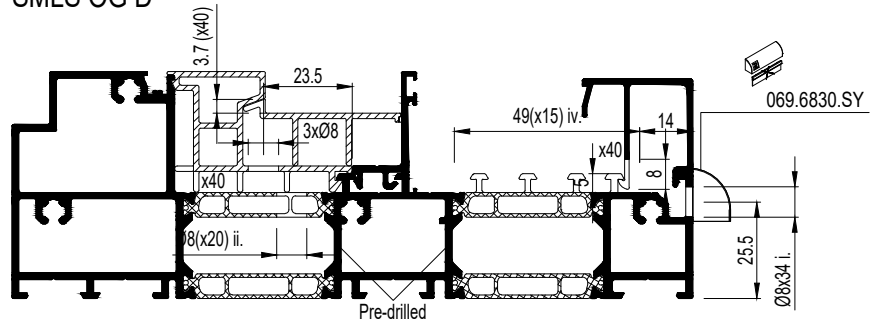

SMLS OG E

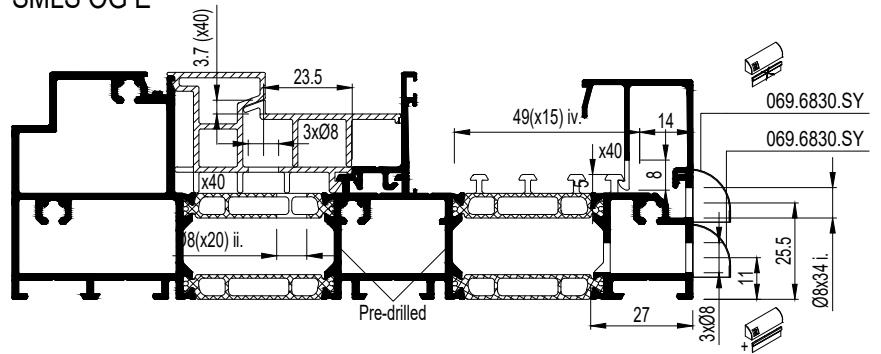

ALLEEN MET KUNSTSTOF PROFIEL 406.0320.04 VOORGEMONTEERD  
 SEULEMENT AVEC PROFIL SYNTHETIQUE 406.0320.04 PRE ASSEMBLE  
 ONLY WITH SYNTHETIC PROFILE 406.0320.04 PREASSEMBLED  
 NUR MIT KUNSTSTOFFPROFIL 406.0320.04 VORMONTIERT

SMLS OG D

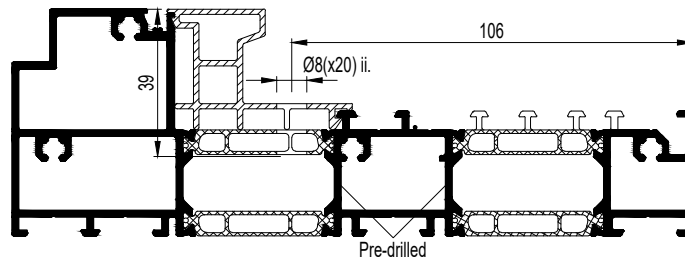

SMLS OG E

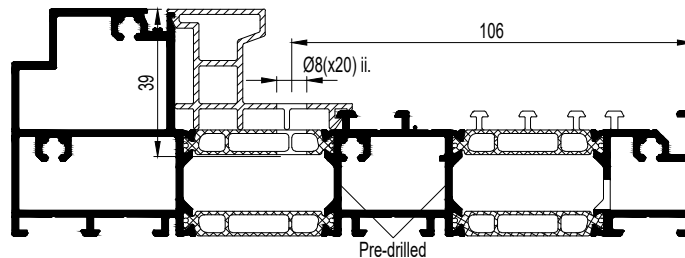

1.1 1.2 1.3

MANUEEL  
 MANUEL  
 MANUAL  
 MANUELL

### SMLS OG A

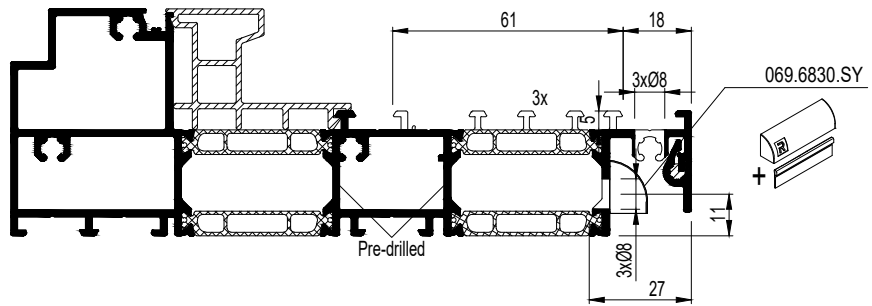

### SMLS OG B

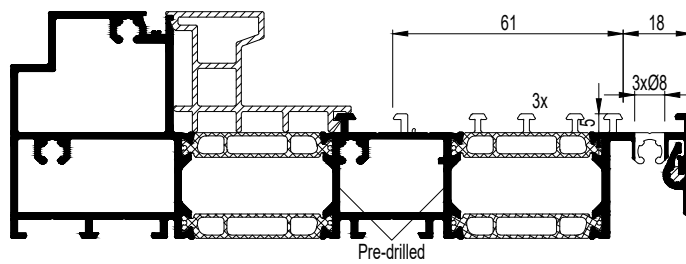

### SMLS OG C

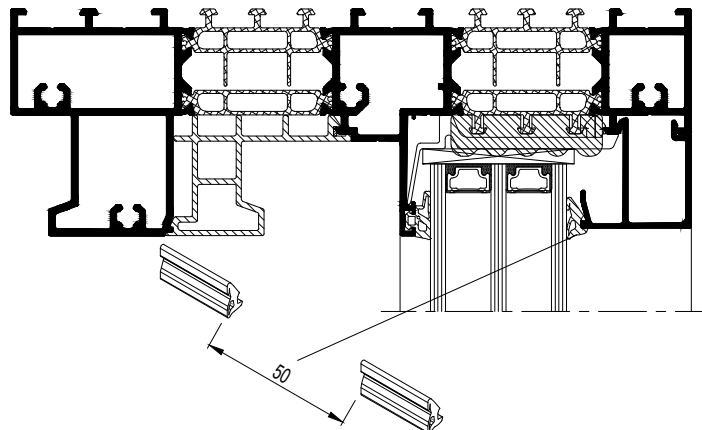
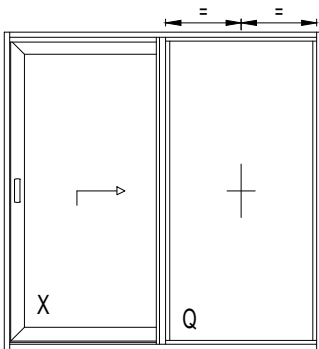
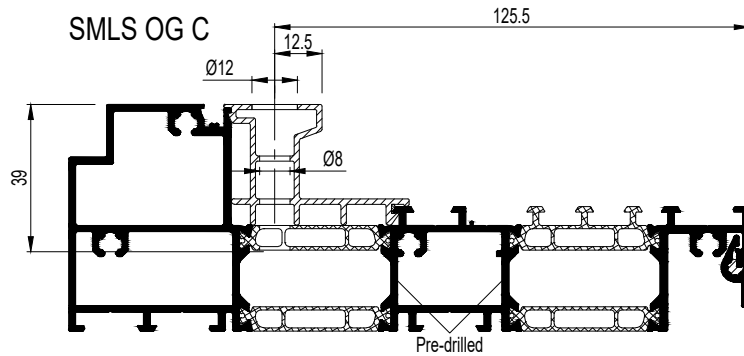

DECOMPRESSIE VAST RAAM  
 DEPRESSION CHASSIS FIXE  
 DEPRESSION FIXED WINDOW  
 DEKOMPRESSION FESTVERGLASUNG



MONTAGEVOLGORDE  
 L'ORDRE DE MONTAGE  
 THE ORDER OF ASSEMBLY  
 MONTAGEREIHENFOLGE

1 2 3 .

schaal - échelle  
 scale - Maßstab  
 1/2

SMLS OG D

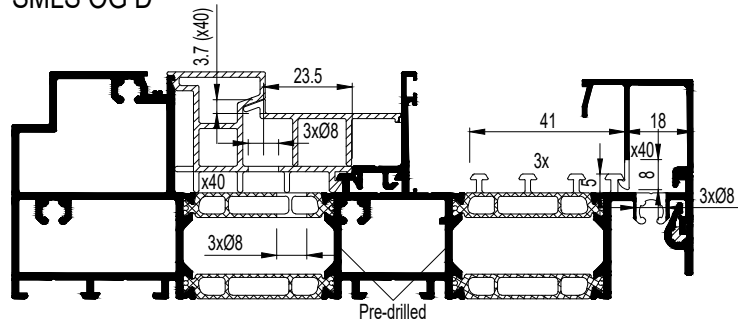

SMLS OG E

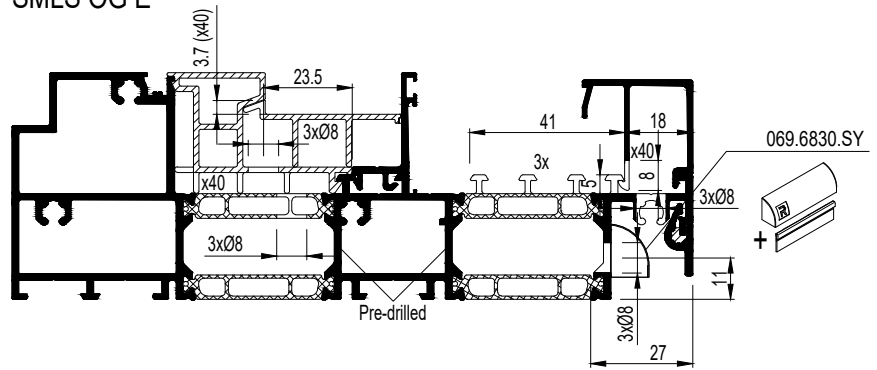

	197.F100.00		406.0320.04 406.0322.04
	097.0839.00		406.0311.XXPU

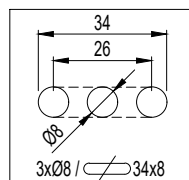

schaal - échelle  
 scale - Maßstab  
 1/2

1.1 1.2 1.3

CNC

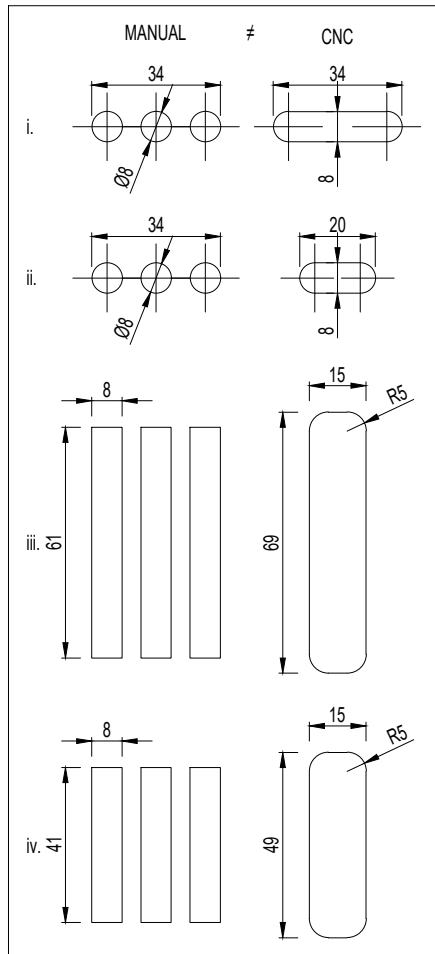

## SMLS OG A

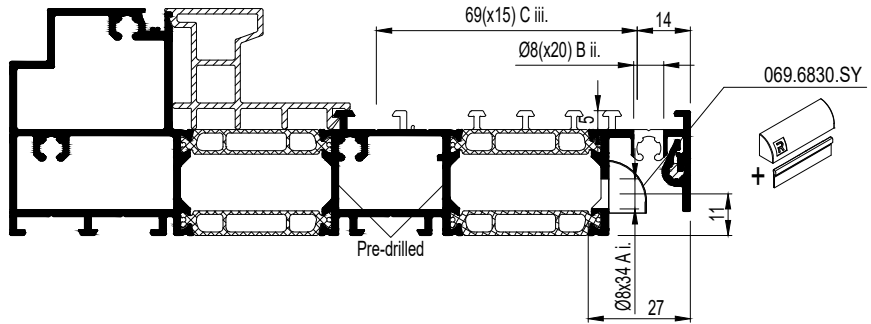

## SMLS OG B

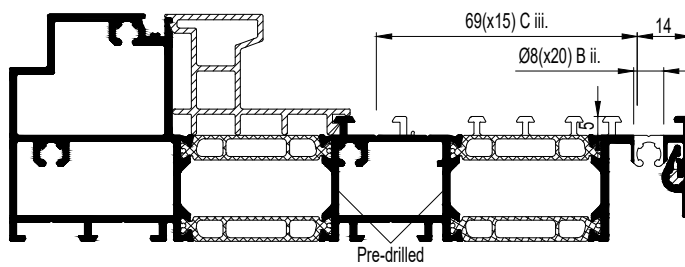

## SMLS OG C

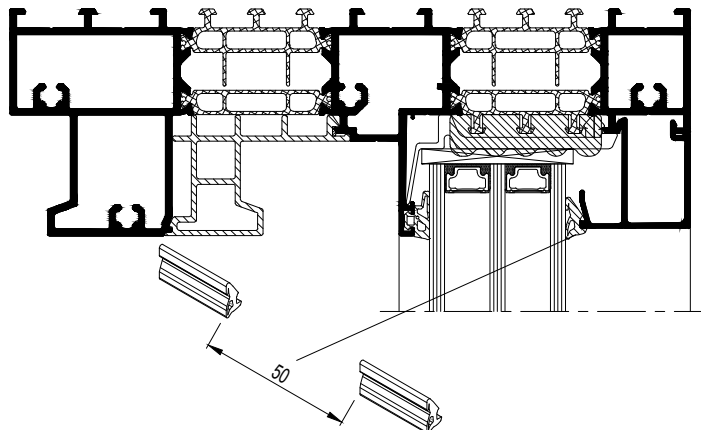
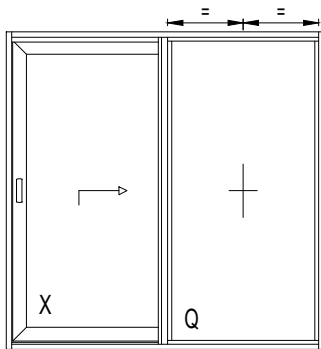
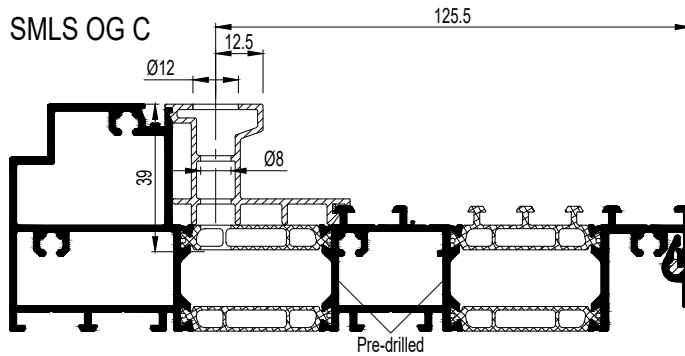

DECOMPRESSIE VAST RAAM  
 DECOMPRESSION CHASSIS FIXE  
 DECOMPRESSION FIXED WINDOW  
 DEKOMPRESSION FESTVERGLASUNG



schaal - échelle  
 scale - Maßstab  
 1/2

MONTAGEVOLGORDE  
 L'ORDRE DE MONTAGE  
 THE ORDER OF ASSEMBLY  
 MONTAGEREIHENFOLGE

1 2 3 .



SMLS OG D

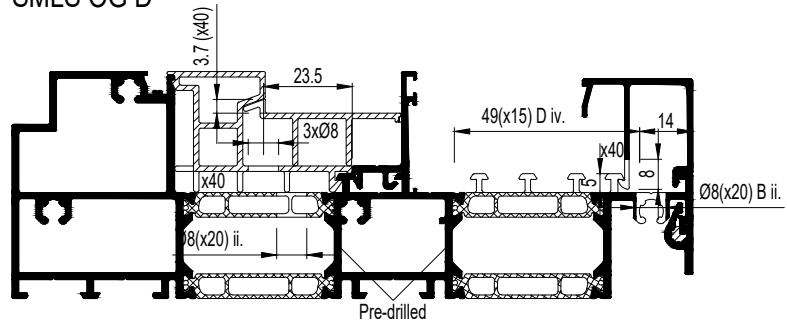

SMLS OG E

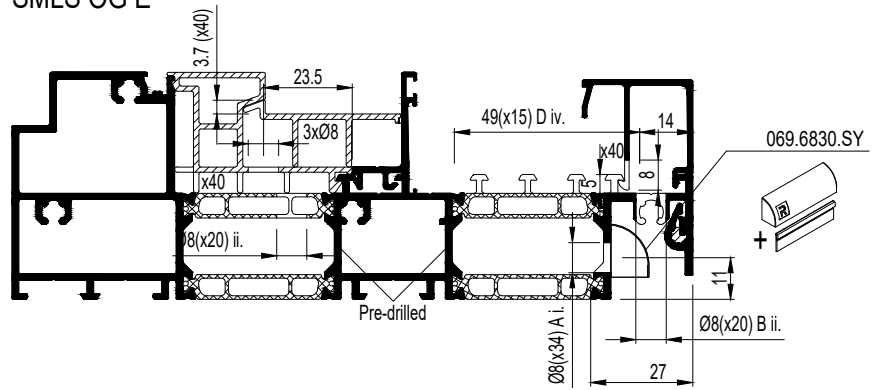

ALLEEN MET KUNSTSTOF PROFIEL 406.0320.04 VOORGEMONTEERD  
 SEULEMENT AVEC PROFILE SYNTHETIQUE 406.0320.04 PRE ASSEMBLE  
 ONLY WITH SYNTHETIC PROFILE 406.0320.04 PREASSEMBLED  
 NUR MIT KUNSTSTOFFPROFIL 406.0320.04 VORMONTIERT



SMLS OG D

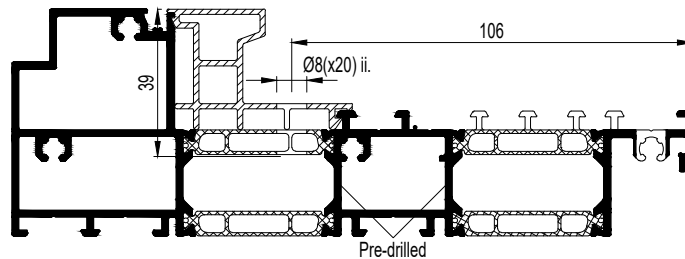

SMLS OG E

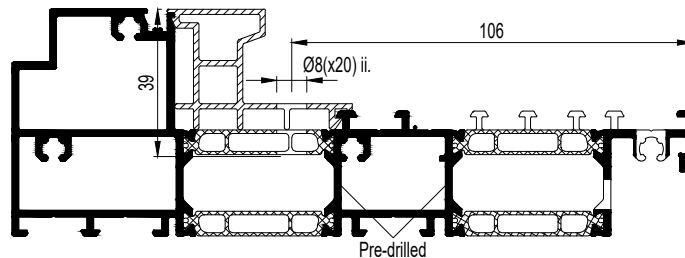

1.1 1.2 1.3

MANUEEL  
 MANUEL  
 MANUAL  
 MANUELL

### SMLS OG A

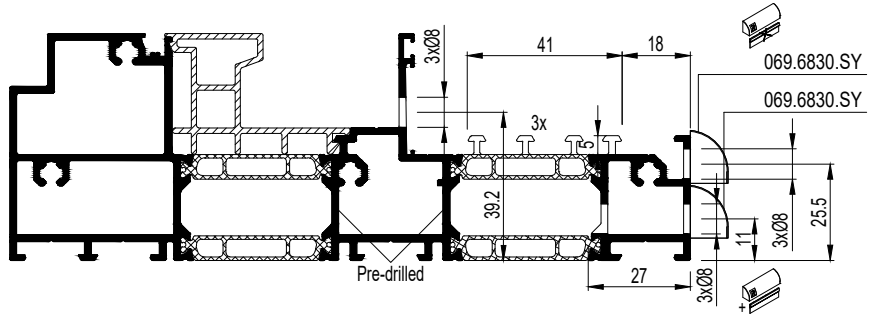

### SMLS OG B

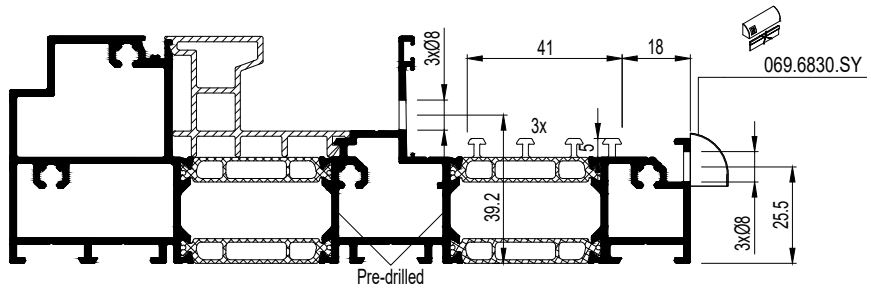

### SMLS OG C

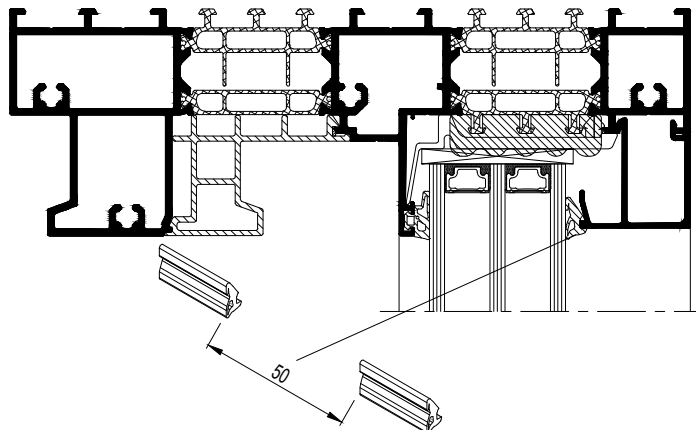
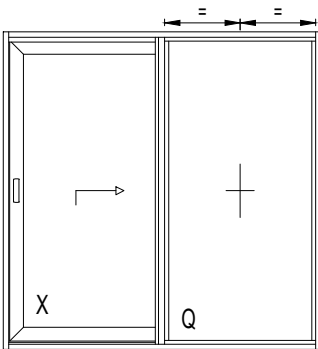
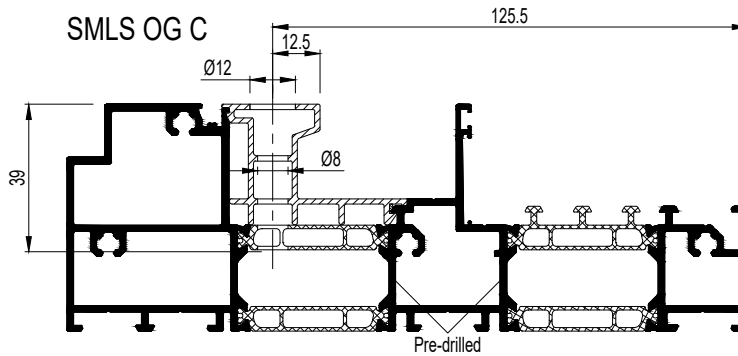

DECOMPRESSIE VAST RAAM  
 DECOMPRESSION CHASSIS FIXE  
 DECOMPRESSION FIXED WINDOW  
 DEKOMPRESSION FESTVERGLASUNG



MONTAGEVOLGORDE  
 L'ORDRE DE MONTAGE  
 THE ORDER OF ASSEMBLY  
 MONTAGEREIHENFOLGE

1 2 3 .

schaal - échelle  
 scale - Maßstab  
 1/2

### SMLS OG D

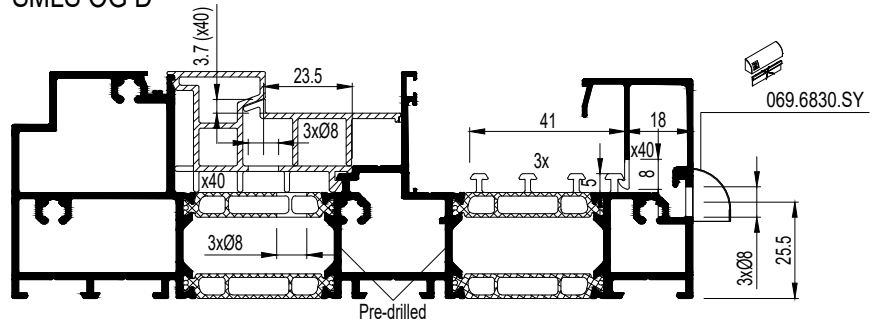

### SMLS OG E

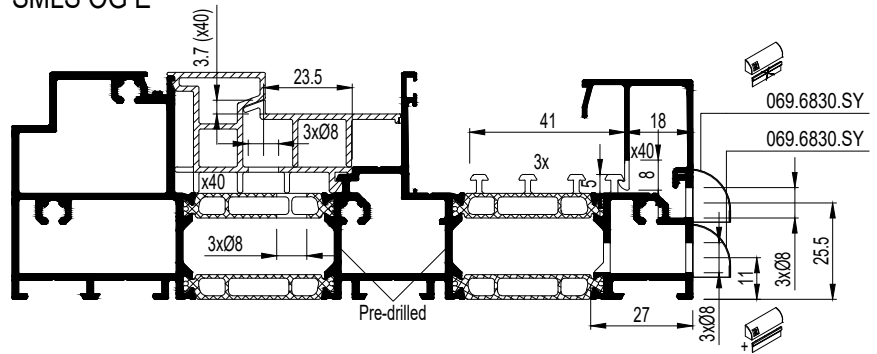

	197.F100.00	406.0320.04	406.0322.04
	097.0839.00	406.0312.XXPU	

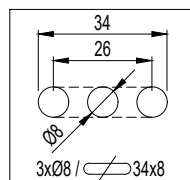

schaal - échelle  
 scale - Maßstab  
 1/2

1.1 1.2 1.3

CNC

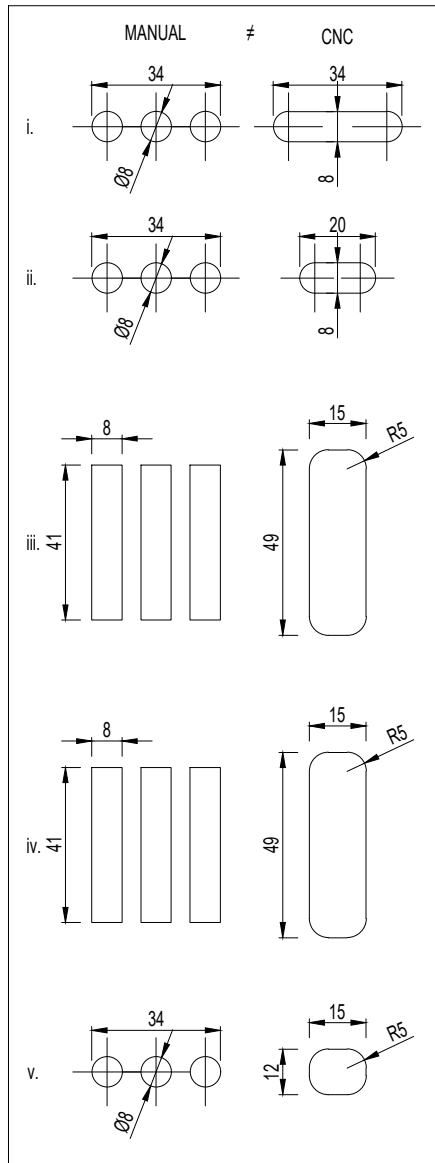

## SMLS OG A

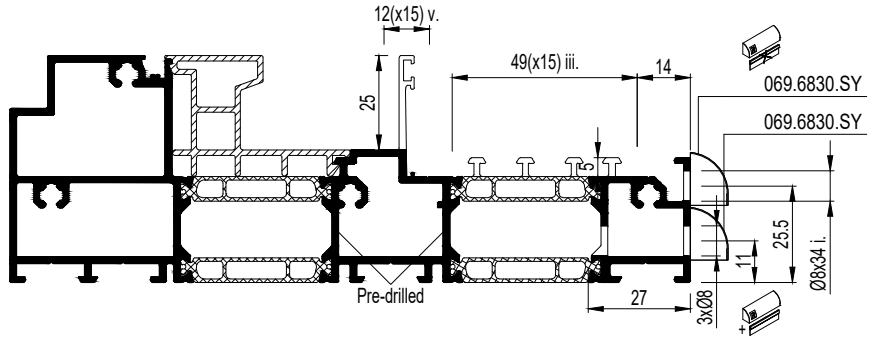

## SMLS OG B

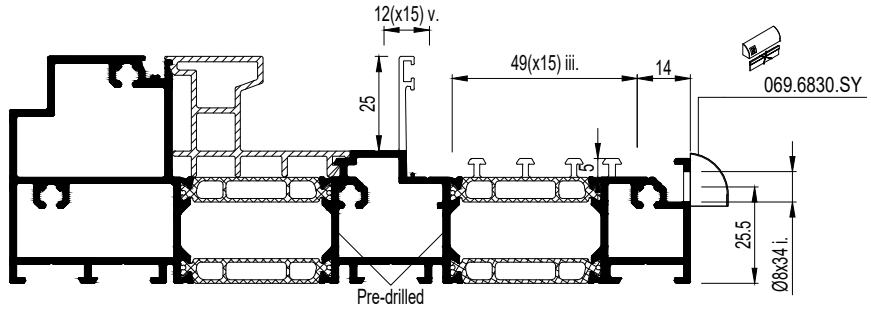

## SMLS OG C

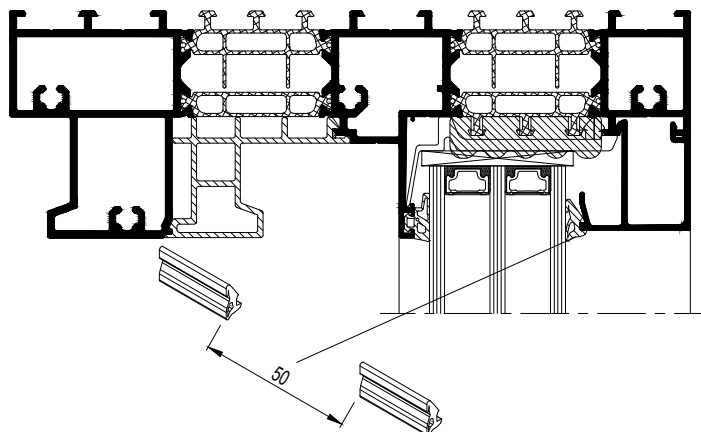
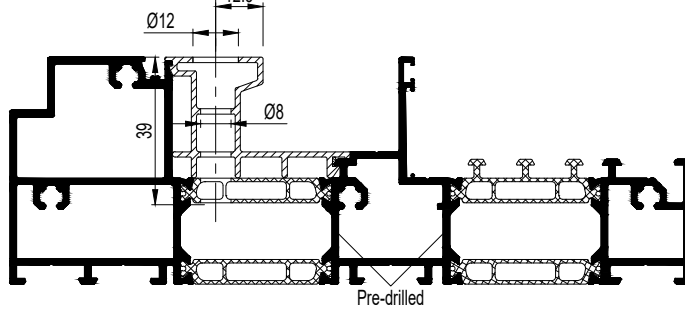

DECOMPRESSIE VAST RAAM  
 DECOMPRESSION CHASSIS FIXE  
 DECOMPRESSION FIXED WINDOW  
 DEKOMPRESSION FESTVERGLASUNG



schaal - échelle  
 scale - Maßstab  
 1/2

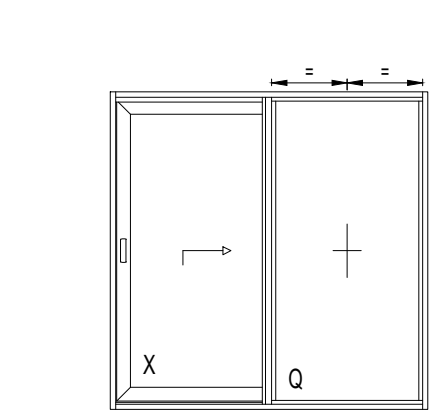

MONTAGEVOLGORDE  
 L'ORDRE DE MONTAGE  
 THE ORDER OF ASSEMBLY  
 MONTAGEREIHENFOLGE

1 2 3 .

SMLS OG D

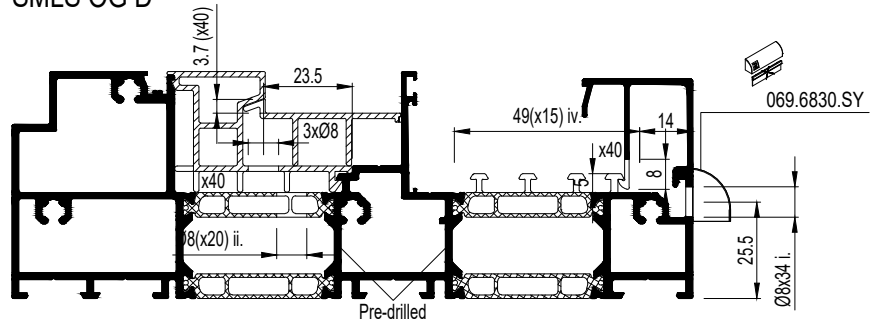

SMLS OG E

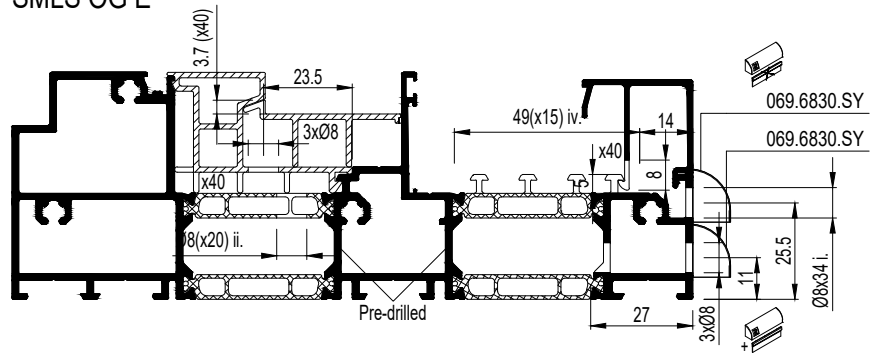

ALLEEN MET KUNSTSTOF PROFIEL 406.0320.04 VOORGEMONTEERD  
 SEULEMENT AVEC PROFILE SYNTHETIQUE 406.0320.04 PRE ASSEMBLE  
 ONLY WITH SYNTHETIC PROFILE 406.0320.04 PREASSEMBLED  
 NUR MIT KUNSTSTOFFPROFIL 406.0320.04 VORMONTIERT

SMLS OG D

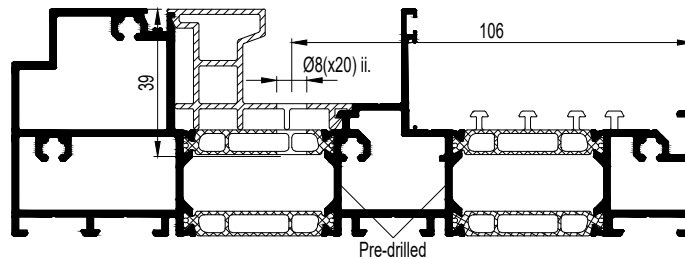

SMLS OG E

